

Advanced Mathematics

Senior Five

Student's Book

© 2020 Rwanda Basic Education Board
All rights reserved

This book is property of the Government of Rwanda. Credit must be
given to REB when the content is quoted

FOREWORD

Dear Student,

Rwanda Basic Education Board (REB) is honored to present senior five Mathematics book for students of advanced level where Mathematics is a major subject. This book will serve as a guide to competence-based teaching and learning to ensure consistency and coherence in the learning of the Mathematics. The Rwandan educational philosophy is to ensure that you achieve full potential at every level of education which will prepare you to be well integrated in society and exploit employment opportunities. The government of Rwanda emphasizes the importance of aligning teaching and learning materials with the syllabus to facilitate your learning process. Many factors influence what you learn, how well you learn and the competences you acquire. Those factors include the relevance of the specific content, the quality of teachers' pedagogical approaches, the assessment strategies and the instructional materials available. In this book, we paid special attention to the activities that facilitate the learning process in which you can develop your ideas and make new discoveries during concrete activities carried out individually or with peers.

In competence-based curriculum, learning is considered as a process of active building and developing knowledge and meanings by the learner where concepts are mainly introduced by an activity, situation or scenario that helps the learner to construct knowledge, develop skills and acquire positive attitudes and values.

For efficiency use of this textbook, your role is to:

- ⦿ Work on given activities which lead to the development of skills;
- ⦿ Share relevant information with other learners through presentations, discussions, group work and other active learning techniques such as role play, case studies, investigation and research in the library, on internet or outside;
- ⦿ Participate and take responsibility for your own learning;
- ⦿ Draw conclusions based on the findings from the learning activities.

To facilitate you in doing activities, the content of this book is self explanatory so that you can easily use it yourself, acquire and

assess your competences. The book is made of units as presented in the syllabus. Each unit has the following structure: the key unit competence is given and it is followed by the introductory activity before the development of mathematical concepts that are connected to real world problems or to other sciences.

The development of each concept has the following points:

- ⊙ It starts by a learning activity: it is a hand on well set activity to be done by students in order to generate the concept to be learnt;
- ⊙ Main elements of the content to be emphasized;
- ⊙ Worked examples; and
- ⊙ Application activities which are activities to be done by the user to consolidate competences or to assess the achievement of objectives.

Even though the book has some worked examples, you will succeed on the application activities depending on your ways of reading, questioning, thinking and grappling ideas of calculus not by searching for similar-looking worked out examples.

Furthermore, to succeed in Mathematics, you are asked to keep trying; sometimes you will find concepts that need to be worked at before you completely understand. The only way to really grasp such a concept is to think about it and work-related problems found in other reference books.

I wish to sincerely express my appreciation to the people who contributed towards the editing of this book, particularly, REB staffs and teachers for their technical support.

Any comment or contribution would be welcome to the improvement of this text book for the next edition.



Dr. Nelson MBARUSHIMANA
Director General, REB



ACKNOWLEDGEMENT

I wish to express my appreciation to the people who played a major role in the development and the editing of senior five Mathematics book for students of advanced level where Mathematics is a major subject. It would not have been successful without active participation of different education stakeholders.

I owe gratitude to Curriculum Officers and teachers whose efforts during the editing exercise of this book were very much valuable. Finally, my word of gratitude goes to the Rwanda Basic Education Board staffs who were involved in the whole process of in-house textbook production.

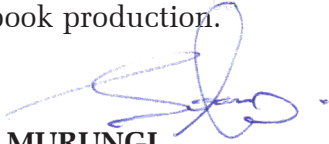

Joan MURUNGI

Head of Curriculum, Teaching and learning Resources Department

ICONS USED IN THIS BOOK

To guide you, each activity in the book is marked by a symbol or icon to show you what kind of activity it is. The icons are as follows:



Practical Activity icon

The hand indicates a practical activity such as curve sketching, draw figures, to have a selection of objects individually or in a group and then present your results or comments.



Group Work icon

Group work means that you are expected to discuss something in groups and report back on what your group discussed. In this way, you learn from each other and how to work together as a group to address or solve a problem.



Pairing Activity icon

This means that you are required to do the activity in pairs, exchange ideas and write down your results.



Research Activity icon

Some activities require you to do research either by reading textbooks or using the internet.

Contents

<i>FOREWORD</i>	<i>iii</i>
<i>ACKNOWLEDGEMENT</i>	<i>v</i>
<i>ICONS USED IN THIS BOOK</i>	<i>vi</i>
Unit 1. Trigonometric Formulae, Equations and Inequalities .1	
1.1. Trigonometric formulae	2
1.1.1. Addition and subtraction formulae	2
1.1.2. Double angle formulae	5
1.1.3. Half angle formulae	7
1.1.4. Transformation of product in sum	8
1.1.5. Transformation of sum in product	9
1.2. Trigonometric equations and inequalities	11
1.2.1. Trigonometric equations	11
1.2.2. Trigonometric inequalities	20
1.3. Applications	27
1.3.1. Simple harmonic motion	27
1.3.2. Refraction of light	28
Unit Summary	31
End of Unit Assessment	33
Unit 2. Sequences	35
2.1. Generalities on sequences	36
2.1.1. Definitions	36
2.1.2. Convergent and divergent sequences	40
2.1.3. Monotone sequences	41
2.2. Arithmetic and harmonic sequences	44
2.2.1. Definition	44
2.2.2. General term of an arithmetic sequence	47
2.2.3. Arithmetic means	49
2.2.4. Arithmetic series	51
2.2.5. Harmonic sequences	52
2.3. Geometric sequences	56
2.3.1. Definition	56
2.3.2. General term of a geometric sequence	58
2.3.3. Geometric means	60
2.3.4. Geometric series	62
2.3.5. Infinity geometric series	64

2.4. Applications	65
Unit Summary.....	69
End of Unit Assessment.....	71
Unit 3. Logarithmic and Exponential Equations.....	75
3.1. Exponential and logarithmic functions	76
3.2. Exponential and logarithmic equations.....	78
3.3. Applications.....	83
Unit Summary.....	91
End of Unit Assessment.....	92
Unit 4. Solving Equations by Numerical Methods.....	95
4.1. Linear Interpolation and extrapolation.....	96
4.1.1. Linear interpolation.....	96
4.1.2. Linear extrapolation	99
4.2. Location of roots	101
4.2.1. Analytical method	101
4.2.2. Graphical method	102
4.3. Iterative methods.....	105
4.3.1. Newton-Raphson method	105
4.3.2. General iteration method	109
Unit Summary	114
End of Unit Assessment.....	115
Unit 5. Trigonometric Functions and their Inverses	117
5.1. Generalities on trigonometric functions and their inverses	118
5.1.1. Domain and range of six trigonometric functions	118
5.1.2. Domain and range of inverses of trigonometric functions.....	122
5.1.3. Parity of trigonometric functions	128
5.2. Limits of trigonometric functions and their inverses.....	135
5.2.1. Limits of trigonometric functions	135
5.2.2. Limits of inverse trigonometric functions	141
5.3. Differentiation of trigonometric functions and their inverses	143
5.3.1. Derivative of sine and cosine	143
5.3.2. Differentiation of inverse trigonometric functions.....	147
5.3.3. Successive derivatives.....	151
5.4. Applications.....	153

Unit Summary.....	155
End of Unit Assessment.....	157
Unit 6. Vector Space of Real Numbers	161
6.1. Vector space \mathbb{R}^3	162
6.1.1. Position of points and vectors in 3 dimensions.....	162
6.1.2. Sub-vector space.....	168
6.1.3. Linear combination	172
6.2. Euclidian vector space \mathbb{R}^3	178
6.2.1. Scalar product of two vectors.....	178
6.2.2. Magnitude (or norm or length) of a vector.....	179
6.2.3. Angle between two vectors	181
6.2.4. Vector product	184
6.2.5. Mixed product	186
6.3. Applications	188
End of Unit Assessment.....	201
Unit 7. Matrices and Determinant of Order 3	205
7.1. Square matrices of order 3	206
7.1.1. Definitions	206
7.1.2. Types of matrices	207
7.1.3. Operations on matrices	208
7.2. Matrix of linear transformation in 3 dimensions	218
7.3. Determinants of order 3	222
7.3.1. Determinant of order 3	222
7.3.2. Matrix inverse.....	228
7.4. Application	232
Unit Summary.....	236
End of Unit Assessment.....	240
Unit 8. Points, Straight Lines, Planes and Sphere in 3D.....	243
8.1. Points in 3 dimensions	244
8.1.1. Location of a point in space	244
8.1.2. Coordinates of a midpoint of a segment and centroid of a geometric figure.....	246
8.1.3. The ratio formula.....	249
8.2. Straight lines in 3 dimensions	250
8.2.1. Equations of lines	250
8.2.2. Condition of co-linearity of 3 points.....	258

8.2.3. Relationships between lines.....	260
8.2.4. Angle between two lines	266
8.2.5. Distance from a point to a line	268
8.2.6. Shortest distance between two skew lines	270
8.3. Planes in 3 dimensions	276
8.3.1. Equations of planes	276
8.3.2. Condition of co-planarity of four points.....	291
8.3.3. Position of a line and a plane	293
8.3.4. Angles of lines and planes	298
8.3.5. Shortest distance from a point to a plane	302
8.3.6. Projection of a line onto the plane	306
8.3.7. Finding image of a point onto the plane.....	307
8.3.8. Position of planes.....	310
8.4. Sphere in 3 dimensions.....	326
8.4.1. Equation of a sphere	326
8.4.2. Position of point and sphere	331
8.4.3. Position of a sphere and a line	333
8.4.4. Position of a sphere and a plane	336
8.4.5. Position of two spheres	344
Unit Summary.....	355
End of Unit Assessment.....	363
Unit 9. Bivariate Statistics	369
9.1. Covariance	370
9.2. Regression lines	374
9.3. Coefficient of correlation	379
9.4. Applications.....	389
Unit Summary.....	391
End of Unit Assessment.....	392
Unit 10. Conditional probability and Bayes Theorem.....	397
10.1. Tree diagram	398
10.2. Independent events	401
10.3. Conditional probability	404
10.4. Bayes theorem and its applications	408
Unit Summary.....	411
End of Unit Assessment.....	412
References	415

Unit 1

Trigonometric Formulae, Equations and Inequalities

Introductory activity

The height h of the cathedral is 485 m. The angle of elevation of the top of the Cathedral from a point 280 m away from the base of its steeple on level ground is θ . By using trigonometric concepts, find the value of this angle in degree.

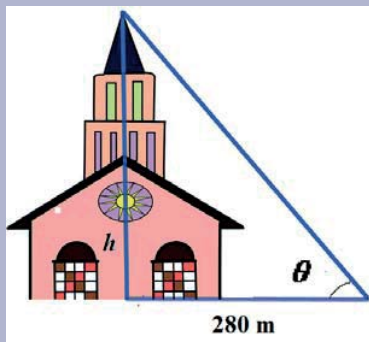

Trigonometry studies relationship involving lengths and angles of a triangle. The techniques in trigonometry are used for finding relevance in navigation particularly satellite systems and astronomy, naval and aviation industries, land surveying and in cartography (creation of maps). Even if those are the scientific applications of the concepts in trigonometry, most of the mathematics we study would seem to have little real-life application. Trigonometry is really relevant in our day to day activities.

2. Objectives

By the end of this unit, a student will be able to:

- Solve trigonometric equations.
- Solve trigonometric -inequalities.
- Use trigonometric formulae, equations and inequalities in real life.

1.1. Trigonometric formulae



Activity 1.1

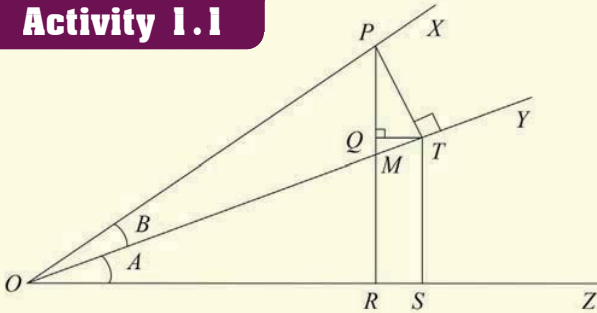

In the diagram, the angle $MOR=A$ and $POT=B$ are each acute and the angle $POR=(A+B)$ is also acute. PT is perpendicular to OY , PR is perpendicular to OZ and QT is perpendicular to PR .

Since QT is parallel to OS ,

$$\angle QTO = \angle TOS = A$$

Since $\angle PTO = 90^\circ$, $\angle PTQ = 90^\circ - A$.

As PQT is a triangle, thus $\angle PQT + \angle PTQ + \angle QPT = 180^\circ$

That is, $90^\circ + (90^\circ - A) + \angle QPT = 180^\circ$

$$180^\circ - A + \angle QPT = 180^\circ$$

Thus, $\angle QPT = A$.

Hence, use right triangles ORP , OST and OTP to find the formula of

a) $\sin(A+B)$

b) $\cos(A+B)$

Deduce the formula of

$\tan(A+B)$, $\sin(A-B)$, $\cos(A-B)$, $\tan(A-B)$

1.1.1. Addition and subtraction formulae

From Activity 1.1, the addition and subtraction formulae are:

$$\cos(x+y) = \cos x \cos y - \sin x \sin y$$

$$\cos(x-y) = \cos x \cos y + \sin x \sin y$$

$$\sin(x+y) = \sin x \cos y + \cos x \sin y$$

$$\sin(x-y) = \sin x \cos y - \cos x \sin y$$

Also,

$$\tan(x+y) = \frac{\tan x + \tan y}{1 - \tan x \tan y}$$

$$\tan(x-y) = \frac{\tan x - \tan y}{1 + \tan x \tan y}$$

$$\cot(x+y) = \frac{\cot x \cot y - 1}{\cot y + \cot x}$$

$$\cot(x-y) = \frac{\cot x \cot y + 1}{\cot y - \cot x}$$

Addition and subtraction formulae are useful when finding trigonometric number of some angles.

Example 1.1

Use addition and subtraction formulae to find $\cos 75^\circ$

Solution

$$\begin{aligned}\cos 75^\circ &= \cos(45^\circ + 30^\circ) \\ &= \cos 45^\circ \cos 30^\circ - \sin 45^\circ \sin 30^\circ \\ &= \frac{\sqrt{2}}{2} \frac{\sqrt{3}}{2} - \frac{\sqrt{2}}{2} \frac{1}{2} \\ &= \frac{\sqrt{6} - \sqrt{2}}{4}\end{aligned}$$

Example 1.2

Use addition and subtraction formulae to find $\sin \frac{\pi}{12}$

Solution

$$\begin{aligned}\sin \frac{\pi}{12} &= \sin\left(\frac{\pi}{4} - \frac{\pi}{6}\right) = \sin \frac{\pi}{4} \cos \frac{\pi}{6} - \cos \frac{\pi}{4} \sin \frac{\pi}{6} \\ &= \frac{\sqrt{2}}{2} \frac{\sqrt{3}}{2} - \frac{\sqrt{2}}{2} \frac{1}{2} = \frac{\sqrt{6} - \sqrt{2}}{4}\end{aligned}$$

Example 1.3

Use addition and subtraction formulae to find $\tan \frac{5\pi}{3}$

Solution

$$\begin{aligned}\tan \frac{5\pi}{3} &= \tan \left(2\pi - \frac{\pi}{3} \right) \\ &= \frac{\tan 2\pi - \tan \frac{\pi}{3}}{1 + \tan 2\pi \tan \frac{\pi}{3}} \\ &= \frac{0 - \sqrt{3}}{1 + 0} = -\sqrt{3}\end{aligned}$$

Application Activity 1.1

- Simplify $2 \sin \theta \sin 4\theta + 2 \cos \theta \cos 4\theta$
- Use addition and subtraction formulae to find
 - $\sin 75^\circ$
 - $\cos \frac{13\pi}{6}$
 - $\tan 330^\circ$
- If $\tan A = \frac{a}{a+1}$, $\tan B = \frac{1}{2a+1}$, show that $A + B = \frac{\pi}{4}$
- Prove that
 - $\frac{\cos 11^\circ + \sin 11^\circ}{\cos 11^\circ - \sin 11^\circ} = \tan 56^\circ$
 - $\sin(n+1)A \sin(n-1)A + \cos(n+1)A \cos(n-1)A = \cos 2A$
 - $\sin(n+1)x \sin(n+2)x + \cos(n+1)x \cos(n+2)x = \cos x$
- Evaluate without using a calculator:
 - $\tan 75^\circ$
 - $\sin 15^\circ$
 - $\sin 47^\circ \cos 13^\circ + \cos 47^\circ \sin 13^\circ$
 - $\cos 70^\circ \cos 10^\circ + \sin 70^\circ \sin 10^\circ$
 - $\frac{\tan 69^\circ + \tan 66^\circ}{1 - \tan 69^\circ \tan 66^\circ}$

1.1.2. Double angle formulae

Activity 1.2



For each of the following relations, replace y with x and give your result.

$$\cos(x + y) = \cos x \cos y - \sin x \sin y$$

$$\cos(x - y) = \cos x \cos y + \sin x \sin y$$

$$\sin(x + y) = \sin x \cos y + \cos x \sin y$$

$$\tan(x + y) = \frac{\tan x + \tan y}{1 - \tan x \tan y}$$

$$\cot(x + y) = \frac{\cot x \cot y - 1}{\cot x + \cot y}$$

From Activity 1.2, we have

$$\cos^2 x + \sin^2 x = 1$$

This relation is the **fundamental relation of trigonometry** as it was seen in s4.

From this relation, we can write

$$\cos^2 x = 1 - \sin^2 x \text{ and } \sin^2 x = 1 - \cos^2 x$$

$$\sin 2x = 2 \sin x \cos x$$

$$\cos 2x = \cos^2 x - \sin^2 x$$

$$\tan 2x = \frac{2 \tan x}{1 - \tan^2 x}$$

$$\cot 2x = \frac{\cot^2 x - 1}{2 \cot x}$$

Example 1.4

Show that $\cos 2A = 1 - 2\sin^2 A$. Hence express $\cos 4x$ in function of $\sin x$ only.

Solution

$$\begin{aligned} \cos 4x &= \cos 2(2x) = 1 - 2 \sin^2 2x \\ &= 1 - 2(2 \sin x \cos x)^2 \\ &= 1 - 2(4 \sin^2 x \cos^2 x) \\ &= 1 - 8 \sin^2 x \cos^2 x \\ &= 1 - 8 \sin^2 x (1 - \sin^2 x) \\ &= 1 - 8 \sin^2 x + 8 \sin^4 x \end{aligned}$$

Example 1.5

Given that $\tan x = \frac{a}{b}$ and $\pi \leq x \leq \frac{3\pi}{2}$, evaluate, in terms of a and b :

a) $\sin 2x$

b) $\tan 2x$

Solution

The given information produces the triangle shown below. Note the signs associated with a and b . The Pythagorean Theorem is used to find the hypotenuse.

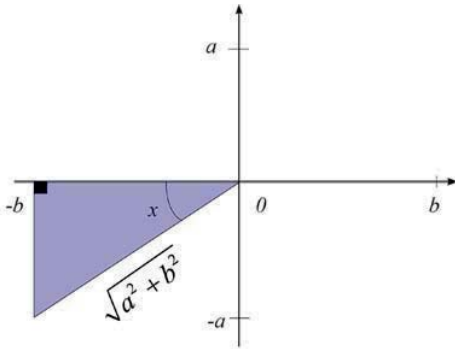

Hint:

$$\sin x = \frac{\text{opposite}}{\text{hypotenuse}}$$

$$\cos x = \frac{\text{adjacent}}{\text{hypotenuse}}$$

$$\tan x = \frac{\text{opposite side}}{\text{adjacent side}}$$

$$= \frac{2 \frac{a}{b}}{1 - \left(\frac{a}{b}\right)^2} = \frac{2ab}{b^2 - a^2}$$

a) $\sin 2x = 2 \sin x \cos x$

$$= 2 \cdot \frac{-a}{\sqrt{a^2 + b^2}} \cdot \frac{-b}{\sqrt{a^2 + b^2}}$$

$$= \frac{2ab}{a^2 + b^2}$$

b) $\tan 2x = \frac{2 \tan x}{1 - \tan^2 x}$

Application Activity 1.2

- Express $\sin 4x$ as function of $\sin x$ and $\cos x$
- Express $\cos 8x$ as function of $\sin x$
- Evaluate exactly $2 \sin 15^\circ \cos 15^\circ$

4. If $\cos A = \frac{\sqrt{2} + 1}{2\sqrt{2}}$, find $\cos 2A$

5. If $\sin A = \frac{\sqrt{5}}{5}$, find $\sin 2A, \cos 2A$ and $\tan 2A$ if A

- a) is acute b) is obtuse

6. Prove that $\sqrt{2 + \sqrt{2 + \sqrt{2 + 2 \cos 8x}}} = 2 \cos x$

1.1.3. Half angle formulae

Activity 1.3



1. Show that $\cos 2x = 1 - 2\sin^2 x$. By letting $\theta = 2x$, deduce the value of $\sin \frac{\theta}{2}$
2. Show that $\cos 2x = 2\cos^2 x - 1$. By letting $\theta = 2x$, deduce the value of $\cos \frac{\theta}{2}$
3. Using results in 1 and 2, deduce the value of $\tan \frac{\theta}{2}$. (Recall that $\tan x = \frac{\sin x}{\cos x}$)

From Activity 1.3,

$$\sin \frac{\theta}{2} = \pm \sqrt{\frac{1 - \cos \theta}{2}}. \text{ We can write } \sin \frac{x}{2} = \pm \sqrt{\frac{1 - \cos x}{2}}$$

$$\text{Also, } \cos \frac{\theta}{2} = \pm \sqrt{\frac{\cos \theta + 1}{2}}. \text{ We can write } \cos \frac{x}{2} = \pm \sqrt{\frac{\cos x + 1}{2}}$$

The half angle formulae are:

$$\sin \frac{x}{2} = \pm \sqrt{\frac{1 - \cos x}{2}}$$

$$\cos \frac{x}{2} = \pm \sqrt{\frac{\cos x + 1}{2}} \text{ the sign } + \text{ or } - \text{ is chosen depending on the}$$

quadrant in which $\frac{x}{2}$ lies

$$\tan \frac{x}{2} = \frac{1 - \cos x}{\sin x} \text{ or } \tan \frac{x}{2} = \frac{\sin x}{1 + \cos x}$$

Example 1.6

Using the half angle formula, find the exact value of $\cos 15^\circ$.

Solution

15° is in first quadrant, then $\cos 15^\circ$ must be positive.

$$\begin{aligned} \cos 15^\circ &= \cos \left(\frac{1}{2}(30^\circ) \right) \\ &= \sqrt{\frac{1 + \cos 30^\circ}{2}} = \sqrt{\frac{1 + \frac{\sqrt{3}}{2}}{2}} \\ &= \frac{\sqrt{2 + \sqrt{3}}}{2} \end{aligned}$$

Application Activity 1.3

1. If $\cos A = -\frac{7}{25}$, find the values of $\sin \frac{1}{2}A$, $\cos \frac{1}{2}A$ and $\tan \frac{1}{2}A$.
2. If $\tan 2A = \frac{7}{24}$, $0 < A < \frac{\pi}{4}$, find the value of $\tan A$.
3. Find the value of $\sin 22\frac{1}{2}^\circ$, $\cos 22\frac{1}{2}^\circ$ and $\tan 22\frac{1}{2}^\circ$.
4. Find the value of $\sin 7\frac{1}{2}^\circ$.
5. Show that $\tan 67\frac{1}{2}^\circ = \sqrt{2} + 1$.

1.1.4. Transformation of product in sum**Activity 1.4**

From addition and subtraction formulae, evaluate:

- | | |
|----------------------------|----------------------------|
| 1. $\sin(x+y) + \sin(x-y)$ | 2. $\sin(x+y) - \sin(x-y)$ |
| 3. $\cos(x+y) + \cos(x-y)$ | 4. $\cos(x+y) - \cos(x-y)$ |

From Activity 1.4, the formulae for transforming product in sum are:

$$\cos x \cos y = \frac{1}{2} [\cos(x+y) + \cos(x-y)]$$

$$\sin x \sin y = -\frac{1}{2} [\cos(x+y) - \cos(x-y)]$$

$$\sin x \cos y = \frac{1}{2} [\sin(x+y) + \sin(x-y)]$$

$$\cos x \sin y = \frac{1}{2} [\sin(x+y) - \sin(x-y)]$$

Example 1.7

Transform in sum the product $\sin 3x \cos 4x$.

Solution

$$\begin{aligned}\sin 3x \cos 4x &= \frac{1}{2} [\sin(3x+4x) + \sin(3x-4x)] \\ &= \frac{1}{2} [\sin 7x + \sin(-x)] \\ &= \frac{1}{2} [\sin 7x - \sin x]\end{aligned}$$

Application Activity 1.4

1. Transform in sum;

a) $\sin x \cos 3x$ b) $\cos 12x \sin 9x$

c) $\sin 9x \sin 11x$ d) $2 \cos 5x \sin 3x$

e) $\cos \frac{5x}{2} \cos \frac{3x}{2}$

2. Prove that

a) $\sin(45^\circ + A) \sin(45^\circ - A) = \frac{1}{2} \cos 2A$

b) $\sec\left(\frac{\pi}{4} + x\right) \sec\left(\frac{\pi}{4} - x\right) = 2 \sec 2x$

c) $\sin 10^\circ \sin 50^\circ \sin 70^\circ = \frac{1}{8}$ without using a calculator

1.1.5. Transformation of sum in product**Activity 1.5**

Using the relations $x + y = p$ and $x - y = q$, express each of the formulae for transforming product in sum in function of p and q .

Hint:

$$\begin{cases} x + y = p \\ x - y = q \end{cases} \Rightarrow \begin{cases} x = \frac{p+q}{2} \\ y = \frac{p-q}{2} \end{cases}$$

From Activity 1.5, the formulae for transforming sum in product are:

$$\cos p + \cos q = 2 \cos \frac{p+q}{2} \cos \frac{p-q}{2}$$

$$\cos p - \cos q = -2 \sin \frac{p+q}{2} \sin \frac{p-q}{2}$$

$$\sin p + \sin q = 2 \sin \frac{p+q}{2} \cos \frac{p-q}{2}$$

$$\sin p - \sin q = 2 \cos \frac{p+q}{2} \sin \frac{p-q}{2}$$

Example 1.8

Transform in product the sum $\sin 3x + \sin 4x$

Solution

$$\begin{aligned} \sin 3x + \sin 4x &= 2 \sin \frac{3x+4x}{2} \cos \frac{3x-4x}{2} \\ &= 2 \sin \frac{7x}{2} \cos \frac{x}{2} \end{aligned}$$

Application Activity 1.5

1. Transform in product

- a) $\cos x + \cos 7x$ b) $\sin 4x - \sin 9x$
 c) $\sin 3x + \sin x$ d) $\cos 2x - \cos 4x$

2. Prove that

a) $\frac{\sin A + \sin B}{\cos A + \cos B} = \tan \frac{A+B}{2}$

b) $\frac{\cos 2B - \cos 2A}{\sin 2A + \sin 2B} = \tan(A-B)$

c) $\frac{\sin 5x - 2 \sin 3x + \sin x}{\cos 5x - \cos x} = \tan x$

1.2. Trigonometric equations and inequalities

1.2.1. Trigonometric equations

The solution of equations reducible to the form

$\sin(x + \alpha) = k$, $\cos(x + \alpha) = k$ and $\tan(x + \alpha) = b$ for $|k| \leq 1$ and $b \in \mathbb{R}$

Activity 1.6



1. Find at least three angles whose sine is $\frac{1}{2}$.
2. Find at least three angles whose cosine is $\frac{\sqrt{2}}{2}$.
3. Find at least three angles whose tangent is $\frac{\sqrt{3}}{3}$.

The solutions of a trigonometric equation for which $0 \leq x \leq 2\pi$ are called **principal solutions** while the expression (involving integer k) of solution containing all values of the unknown angle is called the **general solution** of the trigonometric equation. When the interval of solution is not given, you are required to find a general solution.

Also recall the following identities:

$$\sin \alpha = \sin(\alpha + 2k\pi), k \in \mathbb{Z}$$

$$\sin \alpha = \sin(\pi - \alpha)$$

$$\cos \alpha = \cos(\alpha + 2k\pi), k \in \mathbb{Z}$$

$$\cos \alpha = \cos(-\alpha)$$

$$\tan \alpha = \tan(\alpha + k\pi), k \in \mathbb{Z}$$

$$\tan \alpha = \tan(\alpha + \pi)$$

Example 1.9

Find the principal solutions of the following equations:

a) $\cos x = -\frac{\sqrt{3}}{2}$ b) $\sin x = \frac{1}{\sqrt{2}}$ c) $\sec x = 2$

Solution

a) $\cos x = -\frac{\sqrt{3}}{2}$ is negative $\Rightarrow x$ lies in the 2nd or 3rd quadrant.
 Here $\cos x = -\cos \frac{\pi}{6} = \cos\left(\pi - \frac{\pi}{6}\right)$ or $\cos\left(\pi + \frac{\pi}{6}\right)$

$$\Rightarrow \cos x = \cos \frac{5\pi}{6} \text{ or } \cos \frac{7\pi}{6}$$

$$\text{Thus, } x = \frac{5\pi}{6} \text{ or } x = \frac{7\pi}{6}.$$

The principal solutions are $x = \frac{5\pi}{6}$ or $x = \frac{7\pi}{6}$.

b) $\sin x = \frac{1}{\sqrt{2}}$ is positive $\Rightarrow x$ lies in the 1st or 2nd quadrant.

$$\text{Here } \sin x = \frac{1}{\sqrt{2}} = \sin \frac{\pi}{4} \text{ or } \sin \left(\pi - \frac{\pi}{4} \right)$$

$$\Rightarrow x = \frac{\pi}{4} \text{ or } x = \frac{3\pi}{4}$$

Thus, $x = \frac{\pi}{4}$ or $x = \frac{3\pi}{4}$.

$$\text{c) } \sec x = 2 \Leftrightarrow \frac{1}{\cos x} = 2$$

$\Rightarrow \cos x = \frac{1}{2}$ is positive, thus x lies in the 1st or 4th quadrant.

$$\cos x = \frac{1}{2} = \cos \frac{\pi}{3} \text{ or } \cos \left(2\pi - \frac{\pi}{3} \right)$$

$$\Rightarrow x = \frac{\pi}{3} \text{ or } x = \frac{5\pi}{3}$$

The principal solutions are $x = \frac{\pi}{3}$ or $x = \frac{5\pi}{3}$

Example 1.10

Solve for x in the set of real numbers $\sin x = \frac{1}{2}$.

Solution

$$(1) \sin x = \frac{1}{2}$$

(2) Here, we need to know the angle whose sine is $\frac{1}{2}$.

Then $x = \frac{\pi}{6}$ (5) and so on.

This is not the only solution since we know that $\sin \alpha = \sin(\pi - \alpha)$.

So, $\pi - \frac{\pi}{6} = \frac{5\pi}{6}$ is another solution.

Also, $\sin \alpha = \sin(\alpha + 2k\pi)$.

$$(3) \sin x = \sin \frac{\pi}{6}$$

Then in general, $\sin x = \frac{1}{2}$

$$\sin x = \sin \frac{\pi}{6} \text{ and } x = \frac{\pi}{6} + 2k\pi \text{ or } x = \frac{5\pi}{6} + 2k\pi, k \in \mathbb{Z}$$

Example 1.11

Solve $2 \cos^2 x - 5 \sin x + 1 = 0$ for $x \in [0, \pi]$

Solution

We know that $\cos^2 x = 1 - \sin^2 x$

$$2 \cos^2 x - 5 \sin x + 1 = 0$$

$$\Leftrightarrow 2(1 - \sin^2 x) - 5 \sin x + 1 = 0$$

$$\Leftrightarrow 2 - 2 \sin^2 x - 5 \sin x + 1 = 0$$

$$\Leftrightarrow -2 \sin^2 x - 5 \sin x + 3 = 0$$

$$\Leftrightarrow 2 \sin^2 x + 5 \sin x - 3 = 0$$

Let $t = \sin x$, $-1 \leq t \leq 1$

$$2t^2 + 5t - 3 = 0$$

Either $t = \frac{1}{2}$ or $t = -3$

$t = -3$ is to be rejected since $-1 \leq t \leq 1$

For $t = \frac{1}{2}$,

$$\sin x = \frac{1}{2} \Rightarrow x = \begin{cases} \frac{\pi}{6} + 2k\pi \\ \frac{5\pi}{6} + 2k\pi \end{cases}, k \in \mathbb{R}$$

Thus, since we are given the condition $x \in [0, \pi]$

$$x = \left\{ \frac{\pi}{6}, \frac{5\pi}{6} \right\}$$

Example 1.12

Solve the equation $\cos \theta \cos 30^\circ - \sin \theta \sin 30^\circ = \frac{1}{2}$ for $-180^\circ < \theta < 180^\circ$

Solution

Since $\cos \theta \cos 30^\circ - \sin \theta \sin 30^\circ = \cos(\theta + 30^\circ)$

$$\cos \theta \cos 30^\circ - \sin \theta \sin 30^\circ = \frac{1}{2}$$

$$\Leftrightarrow \cos(\theta + 30^\circ) = \frac{1}{2}$$

That is, $\theta + 30^\circ = \begin{cases} -60^\circ + 360^\circ k \\ 60^\circ + 360^\circ k \end{cases}, k \in \mathbb{Z}$

So, $\theta = -90^\circ$ or 30° [Remember the given condition]

Example 1.13

Solve the equation $\cos(\theta + 60^\circ) = \sin \theta$

Solution

$$\cos(\theta + 60^\circ) = \sin \theta$$

$$\Leftrightarrow \cos \theta \cos 60^\circ - \sin \theta \sin 60^\circ = \sin \theta$$

$$\text{So: } \frac{1}{2} \cos \theta - \frac{\sqrt{3}}{2} \sin \theta = \sin \theta \quad \text{since } \cos 60^\circ = \frac{1}{2} \text{ and } \sin 60^\circ = \frac{\sqrt{3}}{2}$$

$$\text{That is, } \cos \theta - \sqrt{3} \sin \theta = 2 \sin \theta$$

$$\cos \theta = 2 \sin \theta + \sqrt{3} \sin \theta$$

$$\cos \theta = (2 + \sqrt{3}) \sin \theta$$

$$\frac{\cos \theta}{\sin \theta} = 2 + \sqrt{3}$$

$$\tan \theta = \frac{1}{2 + \sqrt{3}}$$

$$\text{So, } \theta = 15^\circ + 180^\circ k \text{ where}$$

$$k \in \mathbb{Z}$$

Alternatively,

From $\sin \theta = \cos(90^\circ - \theta)$,

$$\cos(\theta + 60^\circ) = \cos(90^\circ - \theta);$$

$$\theta + 60^\circ = 90^\circ - \theta + 360^\circ k, \quad k \in \mathbb{Z}, \text{ or}$$

$$\theta + 60^\circ = -90^\circ + \theta + 360^\circ k \text{ which}$$

$$\text{gives } \theta = 15^\circ + 180^\circ k$$

Example 1.14

Solve $\sin^2 x + \sin x \cos x = 0$ for $0^\circ \leq x \leq 360^\circ$

Solution

$$\sin^2 x + \sin x \cos x = 0$$

$$\sin x (\sin x + \cos x) = 0$$

Either $\sin x = 0$ or $\sin x + \cos x = 0$

$$\sin x = 0 \Rightarrow x = 180^\circ k, \quad k \in \mathbb{Z}$$

Considering the given condition:

$$\text{If } k = 0, x = 0^\circ \quad \text{If } k = 1, x = 180^\circ$$

$$\text{If } k = 2, x = 360^\circ$$

$$\sin x + \cos x = 0 \Leftrightarrow \sin x = -\cos x$$

$$\frac{\sin x}{\cos x} = -1$$

$$\tan x = -1$$

$$\tan x = -1 \Rightarrow x = -45^\circ + 180^\circ k$$

$$\text{If } k = 0, x = -45^\circ;$$

If $k = 1$, $x = -45^\circ + 180^\circ = 135^\circ$;

If $k = 2$, $x = -45^\circ + 360^\circ = 315^\circ$;

If $k = 3$, $x = -45^\circ + 540^\circ = 495^\circ$.

But we need positive angles in interval $[0^\circ, 360^\circ]$

Thus, $x \in S = \{0^\circ, 135^\circ, 180^\circ, 315^\circ, 360^\circ\}$

Application Activity 1.6

1. Find the principal solutions of the following equations:

a) $\sin x = \frac{\sqrt{3}}{2}$

b) $\tan x = -\sqrt{3}$

c) $\cot x = \frac{1}{\sqrt{3}}$

d) $\sqrt{3} \tan x = 1$

e) $2 \sin x - \sqrt{3} = 0$

2. Find the general solutions of the following equations:

a) $\sqrt{3} \sec x + 2 = 0$

b) $\tan x + \sqrt{3} = 0$

c) $\sin^2 x - (\sqrt{3} + 1) \cos x \sin x + \cos^2 x = 0$ (**Hint:** Divide each side by $\cos^2 x$)

d) $\sin 2x = 3 \tan x \cos 2x$

The solution of equations reducible to the form $\sin nx = k$

Activity 1.7



Find the general solution for each the following trigonometric equations:

a) $\cos 2x = \frac{1}{\sqrt{2}}$

b) $\sin \frac{x}{2} = -\frac{1}{2}$

c) $\sin mx + \sin nx = 0$ (Remember the transformation of sum into product)

d) $\cos 4x - \cos 2x = 0$

Example 1.15

Solve in the set of real numbers $\cos 2x = \frac{\sqrt{3}}{2}$.

Solution

$$\cos 2x = \frac{\sqrt{3}}{2}$$

$$\cos 2x = \cos \frac{\pi}{6}$$

$$2x = \frac{\pi}{6} + 2k\pi \text{ or } 2x = -\frac{\pi}{6} + 2k\pi \text{ where } k \in \mathbb{Z}$$

$$x = \begin{cases} \frac{\pi}{12} + k\pi \\ -\frac{\pi}{12} + k\pi \end{cases}, \quad k \in \mathbb{Z}$$

Example 1.16

Solve in the set of real numbers $\sin 3x + \sin 5x = 0$

Solution

Transform $\sin 3x + \sin 5x$ in product:

$$\begin{aligned} \sin 3x + \sin 5x &= 2 \sin \frac{8x}{2} \cos \left(-\frac{2x}{2} \right) \\ &= 2 \sin 4x \cos x \end{aligned}$$

Therefore, $\sin 3x + \sin 5x = 0$

$$\Leftrightarrow 2 \sin 4x \cos x = 0$$

$$\Leftrightarrow \sin 4x \cos x = 0$$

$$\Leftrightarrow \sin 4x = 0 \text{ or } \cos x = 0$$

$$\sin 4x = 0$$

Since sine is zero at 0 and π , we can write

$$4x = k\pi$$

$$x = \frac{k\pi}{4}, \quad k \in \mathbb{Z}$$

$$\cos x = 0$$

Since cosine is zero at $\frac{\pi}{2}$ and $\frac{3\pi}{2}$, we can write $x = \frac{\pi}{2} + k\pi$, $k \in \mathbb{Z}$

Then,

$$x = \begin{cases} \frac{k\pi}{4} \\ \frac{\pi}{2} + k\pi \end{cases}, \quad k \in \mathbb{Z}$$

Example 1.17

Solve in the set of real numbers $\tan 3x = 1$

Solution

$$\tan 3x = 1$$

$$\tan 3x = \tan \frac{\pi}{4}$$

$$\Leftrightarrow 3x = \frac{\pi}{4} + k\pi, k \in \mathbb{Z}$$

$$\Rightarrow x = \frac{\pi}{12} + \frac{k\pi}{3}, k \in \mathbb{Z} \quad [\text{since } \tan \alpha = \tan(\alpha + k\pi)]$$

$$\text{Hence, } x = \frac{\pi}{12} + \frac{k\pi}{3}, k \in \mathbb{Z}$$

Example 1.18

Solve $\sin \frac{x}{3} = -\frac{\sqrt{3}}{2}$ for $x \in [0, 2\pi]$

Solution

$$\sin \frac{x}{3} = -\frac{\sqrt{3}}{2} \text{ for } x \in [0, 2\pi]$$

$$\frac{x}{3} = \begin{cases} -\frac{\pi}{3} + 2k\pi \\ \pi - \left(-\frac{\pi}{3}\right) + 2k\pi \end{cases}$$

$$\frac{x}{3} = \begin{cases} -\frac{\pi}{3} + 2k\pi \\ \frac{4\pi}{3} + 2k\pi \end{cases} \Rightarrow x = \begin{cases} -\pi + 6k\pi \\ 4\pi + 6k\pi \end{cases}$$

Since we are given the condition $x \in [0, 2\pi]$, we need to substitute k with some integers ($\dots, -2, -1, 0, 1, 2, \dots$). But doing this, no value can be found in the given interval. Thus, there is no solution.

Example 1.19

Solve the equation $\sin 3x = \frac{1}{2}$ for $x \in [0, 2\pi]$

Solution

$$\sin 3x = \frac{1}{2}$$

$$3x = \begin{cases} \frac{\pi}{6} + 2k\pi \\ \frac{5\pi}{6} + 2k\pi \end{cases}, k \in \mathbb{Z}$$

$$x = \begin{cases} \frac{\pi}{18} + \frac{2}{3}k\pi \\ \frac{5\pi}{18} + \frac{2}{3}k\pi \end{cases}, k \in \mathbb{Z}$$

As the condition is $x \in [0, 2\pi]$, we need to find all possible values in the given interval. Since we need the positive angles, we will take k to be a positive integer or zero.

$$k = 0 \Rightarrow x = \begin{cases} \frac{\pi}{18} \\ \frac{5\pi}{18} \end{cases}, k = 1 \Rightarrow x = \begin{cases} \frac{\pi}{18} + \frac{2}{3}\pi = \frac{13\pi}{18} \\ \frac{5\pi}{18} + \frac{2}{3}\pi = \frac{17\pi}{18} \end{cases},$$

$$k = 2 \Rightarrow x = \begin{cases} \frac{\pi}{18} + \frac{4}{3}\pi = \frac{25\pi}{18} \\ \frac{5\pi}{18} + \frac{4}{3}\pi = \frac{29\pi}{18} \end{cases} \quad k = 3 \Rightarrow x = \begin{cases} \frac{\pi}{18} + \frac{6}{3}\pi = \frac{37\pi}{18} \\ \frac{5\pi}{18} + \frac{6}{3}\pi = \frac{41\pi}{18} \end{cases}$$

For $k = 3$, the obtained angles fall out of the given interval. Looking, the obtained angles for $k = 3$, we see that they are equivalent to the angles obtained for $k = 0$. This means that if we continue, we will find the angles equivalent to previous angles.

Thus,

$$x \in \left\{ \frac{\pi}{18}, \frac{5\pi}{18}, \frac{13\pi}{18}, \frac{17\pi}{18}, \frac{25\pi}{18}, \frac{29\pi}{18} \right\}$$

Application Activity 1.7

Solve

- $\cos 8x = -\frac{1}{2}$
- $\sin 3x \cos 7x = 0$ for $0^\circ < \theta \leq 180^\circ$
- $6 \cos^2 \theta + \sin \theta - 5 = 0$ for $0^\circ < \theta \leq 360^\circ$

4. $\frac{\tan 47^\circ - \tan \theta}{1 + \tan 47^\circ \tan \theta} = \frac{3}{2}$
5. $\sin 3x + \sin x = 0$
6. $\cos 5x + \cos 3x = 0$
7. $\sin 7x - \sin x = \sin 3x$
8. $\cos x + \cos 3x + \cos 5x + \cos 7x = 0$

Solving equations of the form $a \sin x + b \cos x = c$

Activity 1.8



Consider the equation; $\sqrt{3} \cos x - \sin x = \sqrt{3}$

1. Divide each term by $\sqrt{3}$.
2. Letting $\tan \alpha$ be the coefficient of $\cos x$ obtained in 1, find the value of α ($-\pi < \alpha \leq \pi$).
3. Replace the coefficient of $\cos x$ obtained in 1 by $\frac{\sin \alpha}{\cos \alpha}$ and find the expression of $\cos \alpha$.
4. Use addition formula to find the new equation and deduce the value(s) of x .

From Activity 1.8,

One of the methods of solving the equation $a \sin x + b \cos x = c$, we start by dividing each side by a where $a \neq 0$.

That is, $\sin x + \frac{b}{a} \cos x = \frac{c}{a}$

Now, let $\tan \alpha = \frac{b}{a} \Rightarrow \alpha = \tan^{-1} \left(\frac{b}{a} \right)$

Replace $\frac{b}{a}$ by $\frac{\sin \alpha}{\cos \alpha}$, multiply each side by $\cos \alpha$ and then use addition formula.

Example 1.20

Solve $3 \sin x + \sqrt{3} \cos x = 3$

Solution

$$3 \sin x + \sqrt{3} \cos x = 3 \Leftrightarrow \sin x + \frac{\sqrt{3}}{3} \cos x = 1$$

$$\text{Let } \tan \alpha = \frac{\sqrt{3}}{3} \Rightarrow \alpha = \frac{\pi}{6}$$

$$\sin x + \frac{\sin \alpha}{\cos \alpha} \cos x = 1$$

$$\Leftrightarrow \sin x \cos \alpha + \sin \alpha \cos x = \cos \alpha$$

$$\Leftrightarrow \sin(x + \alpha) = \cos \alpha$$

$$\Leftrightarrow \sin\left(x + \frac{\pi}{6}\right) = \cos \frac{\pi}{6} \Leftrightarrow \sin\left(x + \frac{\pi}{6}\right) = \frac{\sqrt{3}}{2}$$

$$x + \frac{\pi}{6} = \begin{cases} \frac{\pi}{3} + 2k\pi \\ \frac{2\pi}{3} + 2k\pi \end{cases} \Rightarrow x = \begin{cases} \frac{\pi}{6} + 2k\pi \\ \frac{\pi}{2} + 2k\pi \end{cases}, \quad k \in \mathbb{Z}$$

Application Activity 1.8

Solve in \mathbb{R}

1. $\cos x + \sqrt{3} \sin x = \sqrt{3}$

2. $\cos x + \sin x = \sqrt{2}$

3. $\cos x - \sin x = -1$

4. $\sqrt{3} \cos x + \sin x = \sqrt{2}$

5. $2 \sin x + \sqrt{3} \cos x = 1 + \sin x$

6. $\sqrt{2} \sec x + \tan x = 1$

1.2.2. Trigonometric inequalities

Activity 1.9



On a trigonometric circle, shade the region containing the angle whose

- sine is less than 0
- cosine is greater than or equal to $\frac{1}{2}$
- sine is greater than $\frac{\sqrt{3}}{2}$
- cosine is less than or equal to $-\frac{\sqrt{2}}{2}$

When solving inequalities, first replace the inequality sign with equal sign and then solve. Find all non equivalent angles in $[0, 2\pi]$. Place these angles on a trigonometric circle. They will divide the circle into arcs. Choose the arcs containing the angles corresponding to the given inequality.

Example 1.21Solve $\sin x < \frac{1}{2}$ and $\sin x > \frac{1}{2}$ **Solution**

$$\sin x = \frac{1}{2}$$

$$x = \begin{cases} \frac{\pi}{6} + 2k\pi \\ \frac{5\pi}{6} + 2k\pi \end{cases} \text{ or}$$

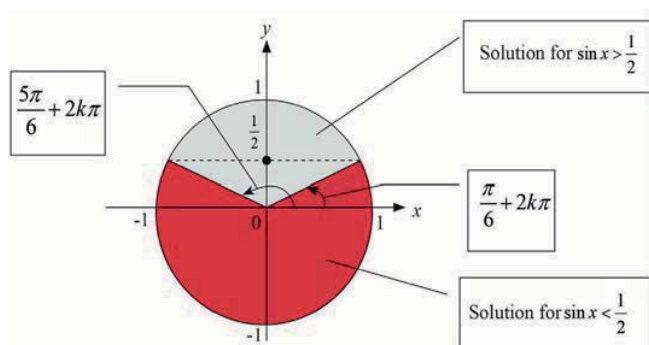
Solution for $\sin x < \frac{1}{2}$

$$x = \left] 0 + 2k\pi, \frac{\pi}{6} + 2k\pi \left[\cup \left] \frac{5\pi}{6} + 2k\pi, 2\pi + 2k\pi \left[, k \in \mathbb{Z}$$

Or

$$x = \left] 2k\pi, \frac{\pi}{6} + 2k\pi \left[\cup \left] \frac{5\pi}{6} + 2k\pi, 2\pi(1+k) \left[, k \in \mathbb{Z}$$

Solution for $\sin x > \frac{1}{2}$

$$x = \left] \frac{\pi}{6} + 2k\pi, \frac{5\pi}{6} + 2k\pi \left[, k \in \mathbb{Z}$$

Example 1.22Solve $\cos x \geq \frac{\sqrt{2}}{2}$ for $x \in [0, 2\pi]$ **Solution**

$$\cos x = \frac{\sqrt{2}}{2}$$

$$x = \pm \frac{\pi}{4}$$

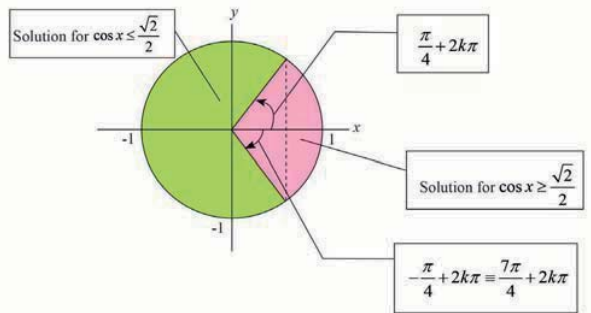

Since we are given the condition $x \in [0, 2\pi]$, the angle $-\frac{\pi}{4}$ will be replaced by its positive equivalent angle in the given interval, which is $\frac{7\pi}{4}$. Thus,

$$S = \left[0, \frac{\pi}{4}\right] \cup \left[\frac{7\pi}{4}, 2\pi\right]$$

Example 1.23

Solve a) $\sin 2x \leq \frac{1}{2}$ b) $\sin 2x \geq \frac{1}{2}$

Solution

a) $\sin 2x = \frac{1}{2}$

$$2x = \begin{cases} \frac{\pi}{6} + 2k\pi \\ \frac{5\pi}{6} + 2k\pi \end{cases} \Rightarrow x = \begin{cases} \frac{\pi}{12} + k\pi \\ \frac{5\pi}{12} + k\pi \end{cases}$$

As it can be seen, there are more than two values in the interval $[0, 2\pi]$. To see them, substitute k with different integers starting with 0:

$$k = 0, x = \begin{cases} \frac{\pi}{12} \\ \frac{5\pi}{12} \end{cases} \quad k = 1, x = \begin{cases} \frac{\pi}{12} + \pi = \frac{13\pi}{12} \\ \frac{5\pi}{12} + \pi = \frac{17\pi}{12} \end{cases},$$

$$k = 2, x = \begin{cases} \frac{\pi}{12} + 2\pi = \frac{25\pi}{12} \\ \frac{5\pi}{12} + 2\pi = \frac{29\pi}{12} \end{cases}$$

The values that fall in the interval $[0, 2\pi]$ are $\frac{\pi}{12}, \frac{5\pi}{12}, \frac{13\pi}{12}$ and $\frac{17\pi}{12}$.

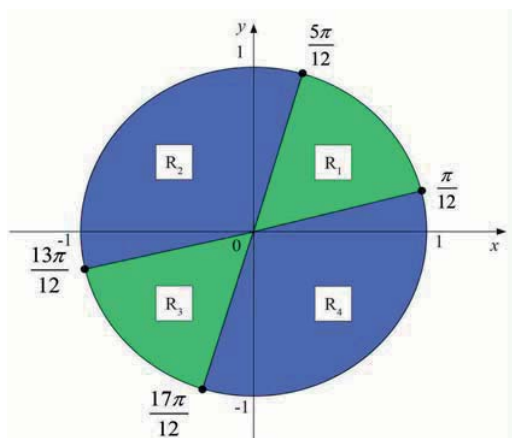

We have four regions R_1 , R_2 , R_3 and R_4 . To find the regions that contain the solution, we will take one value in each region and check if it satisfies the given inequality or not.

Start with the inequality $\sin 2x \leq \frac{1}{2}$:

For R_1 , take for example $x = \frac{\pi}{4}$:

$$\sin 2 \frac{\pi}{4} = \sin \frac{\pi}{2} = 1 > \frac{1}{2}$$

It is inconsistent to the given inequality.

For R_2 , take for example $x = \pi$: $\sin 2\pi = 0 < \frac{1}{2}$

It satisfies the given inequality.

For R_3 , take for example $x = \frac{15\pi}{12}$:

$$\sin 2 \frac{5\pi}{4} = \sin \frac{5\pi}{2} = 1 > \frac{1}{2}$$

It is inconsistent to the given inequality.

For R_4 , take for example $x = 0$: $\sin 0 = 0 < \frac{1}{2}$

It satisfies the given inequality.

Then, the solution of the inequality $\sin 2x \leq \frac{1}{2}$ is the set of all angles found in region 2 and region 4. Remember that since no condition is given, we will use equivalent angles property.

That is,

$$S = \left[2k\pi, \frac{\pi}{12} + 2k\pi \right] \cup \left[\frac{5\pi}{12} + 2k\pi, \frac{13\pi}{12} + 2k\pi \right] \cup \left[\frac{17\pi}{12} + 2k\pi, 2\pi(1+k) \right], \quad k \in \mathbb{Z}$$

b) From the trigonometric circle in a), the solution of the inequality $\sin 2x \geq \frac{1}{2}$ is the set of all angles found in region 1 and region 2.

That is,

$$S = \left[\frac{\pi}{12} + 2k\pi, \frac{5\pi}{12} + 2k\pi \right] \cup \left[\frac{13\pi}{12} + 2k\pi, \frac{17\pi}{12} + 2k\pi \right], \quad k \in \mathbb{Z}$$



Notice

We can also use sign table

x	0	$\frac{\pi}{12}$	$\frac{5\pi}{12}$	$\frac{13\pi}{12}$	$\frac{17\pi}{12}$	2π
$\sin 2x - \frac{1}{2}$	-	-	0	+	0	-
	-	-	0	+	0	-

Now, it is simple to write the solution set considering the given inequality.

Example 1.24

Solve $\sin x + \sin 3x < -\sin 2x$

Solution

$$\sin x + \sin 3x < -\sin 2x$$

$$\sin x + \sin 3x + \sin 2x < 0$$

$$2 \sin 2x \cos(-x) + \sin 2x < 0 \quad [\text{Sum in product}]$$

$$2 \sin 2x \cos x + \sin 2x < 0$$

$$\sin 2x(2 \cos x + 1) < 0$$

First, we solve for $\sin 2x(2 \cos x + 1) = 0$

$$\sin 2x = 0 \Rightarrow x = \frac{k\pi}{2}$$

$$2 \cos x + 1 = 0 \Rightarrow \cos x = -\frac{1}{2} \Rightarrow x = \pm \frac{2\pi}{3} + 2k\pi$$

To construct sign table, we need to know all the values of x that belong to the interval $[0, 2\pi]$

For the first case, we have $0, \frac{\pi}{2}, \pi, \frac{3\pi}{2}, 2\pi$

For the second case, we have $\frac{2\pi}{3}, \frac{4\pi}{3}$

Sign table

x	0	$\frac{\pi}{2}$	$\frac{2\pi}{3}$	π	$\frac{4\pi}{3}$	$\frac{3\pi}{2}$	2π						
$\sin 2x$	0	+	0	-	-	-	0	+	+	+	0	-	0
$2 \cos x + 1$		+	+	+	0	-	-	-	0	+	+	+	
$\sin 2x(2 \cos x + 1)$	0	+	0	-	0	+	0	-	0	+	0	-	0

Thus,

$$S = \left] \frac{\pi}{2} + 2k\pi, \frac{2\pi}{3} + 2k\pi \right[\cup \left] \pi + 2k\pi, \frac{4\pi}{3} + 2k\pi \right[\cup \left] \frac{3\pi}{2} + 2k\pi, 2\pi + 2k\pi \right[, k \in \mathbb{Z}$$

Example 1.25Solve $\tan x + \cot x < -4$ for $x \in [0, \pi]$ **Solution**

$$\tan x + \cot x < -4$$

$$\frac{\sin x}{\cos x} + \frac{\cos x}{\sin x} + 4 < 0$$

$$\frac{\sin x \sin x + \cos x \cos x + 4 \cos x \sin x}{\cos x \sin x} < 0$$

$$\frac{1 + 2(2 \cos x \sin x)}{\frac{2 \cos x \sin x}{2}} < 0$$

$$\frac{1 + 2 \sin 2x}{\frac{\sin 2x}{2}} < 0$$

$$\frac{2(1 + 2 \sin 2x)}{\sin 2x} < 0$$

Case 1

$$1 + 2 \sin 2x = 0$$

$$\Rightarrow \sin 2x = -\frac{1}{2}$$

$$2x = \begin{cases} -\frac{\pi}{6} + 2k\pi \\ \frac{7\pi}{6} + 2k\pi \end{cases} \Rightarrow x = \begin{cases} -\frac{\pi}{12} + k\pi \\ \frac{7\pi}{12} + k\pi \end{cases}$$

We need values in interval $[0, \pi]$

$$k = 0 \qquad k = 1 \qquad k = 2$$

$$x = \begin{cases} -\frac{\pi}{12} \\ \frac{7\pi}{12} \end{cases} \qquad x = \begin{cases} \frac{11\pi}{12} \\ \frac{19\pi}{12} \end{cases} \qquad x = \begin{cases} \frac{23\pi}{12} \\ \frac{31\pi}{12} \end{cases}$$

We take $\frac{7\pi}{12}$ and $\frac{11\pi}{12}$

Case 2

$$\sin 2x = 0 \Rightarrow x = \frac{k\pi}{2}$$

$$k = 0, x = 0 \qquad k = 1, x = \frac{\pi}{2} \qquad k = 2, x = \pi \qquad k = 3, x = \frac{3\pi}{2}$$

We take $0, \frac{\pi}{2}$ and π but for these values, there is no solution since they make the denominator to be zero.

Sign table

x	0	$\frac{\pi}{2}$	$\frac{7\pi}{12}$	$\frac{11\pi}{12}$	π				
$1 + 2 \sin 2x$		+	+	+	0	-	0	+	+
$\sin 2x$	0	+	0	-	-	-	-	-	0
$\frac{1 + 2 \sin 2x}{\sin 2x}$		+		-	0	+	0	-	

$$\text{Thus, } S = \left] \frac{\pi}{2}, \frac{7\pi}{2} \right[\cup \left] \frac{11\pi}{12}, \pi \right[$$

Application Activity 1.9

Solve

- $\sin x \leq \frac{\sqrt{3}}{2}$
- $\sin x \cos 2x > 0$
- $\sin 3x < -\frac{1}{2}$
- $\cos^2 x \geq 1$

1.3. Applications

1.3.1. Simple harmonic motion



Activity 1.10

Discuss how trigonometric theory is used in harmonic motion.

An object that moves on a coordinate axis is in simple harmonic motion if its distance from the origin, d , at time t is given by either $d = a \cos \omega t$ or $d = a \sin \omega t$.

The motion has amplitude $|a|$; the maximum displacement of the object from its rest position. The period of the motion is $\frac{2\pi}{\omega}$, where $\omega > 0$. The period gives the time it takes for the motion to go through one complete cycle (where a cycle is one complete repetition of the pattern).

In describing simple harmonic motion, the equation with the cosine function, $d = a \cos \omega t$, is used if the object is at its greatest distance from rest position, the origin, at $t = 0$. By contrast, the equation with the sine function, $d = a \sin \omega t$, is used if the object is at its rest position, the origin at $t = 0$.

Example 1.26

If the instantaneous voltage in a current is given by the equation $E = 204 \sin 3680t$, where E is expressed in volts and t is expressed in seconds, find E if $t = 0.27$ seconds.

Solution

$$E = 204 \sin 3680t$$

$$E = 204 \sin [(3680)(0.27)]$$

$$E = 204 \sin 993.6$$

$$E \approx 154 \text{ volts}$$

Example 1.27

The horizontal displacement d of the end of a pendulum is $d = K \sin 2\pi t$. Find K if $d = 12$ centimetres and $t = 3.25$ seconds.

Solution

$$d = K \sin 2\pi t$$

$$12 \approx K \sin [(2)(3.1415)(3.25)]$$

$$12 \approx K \sin 20.42$$

$$K \approx \frac{12}{\sin 20.42}$$

$$K \approx 12$$

1.3.2. Refraction of light**Activity 1.11**

Discuss on how trigonometric theory is used in refraction of a light.

In optics, light changes speed as it moves from one medium to another (for example, from air into the glass of the prism). This speed change causes the light to be refracted and to enter the new medium at a different angle (Huygens principle).

A prism is a transparent optical element with flat, polished surfaces that refract light.

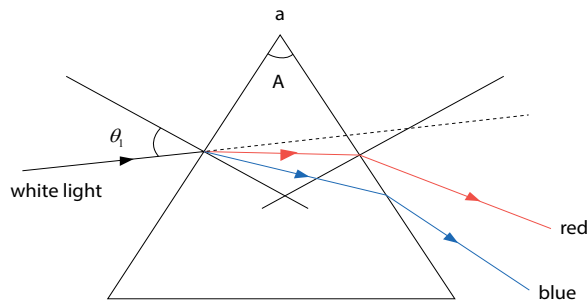

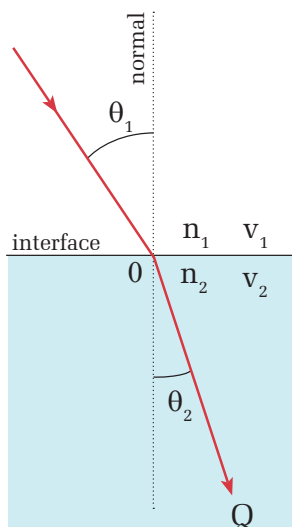

The degree of bending of the light's path depends on the angle that the incident beam of light makes with the surface, and on the ratio between the refractive indices of the two media (Snell's law).

If the light is traveling from a rarer region (lower refractive index) to a denser region (higher refractive index), it will bend towards the normal but if it is traveling from a denser region (higher refractive index) to a rarer region (lower refractive index), it will bend away from the normal.

Snell's law state that: $n_1 \sin \theta_1 = n_2 \sin \theta_2$

Example 1.28

Light travels from air into an optical fiber with an index of refraction of 1.44

- In which direction does the light bend?
- If the angle of incidence on the end of the fiber is 22° , what is the angle of refraction inside the fiber?
- Sketch the path of light as it changes media.

Solution

a) Since the light is traveling from a rarer region (lower n) to a denser region (higher n), it will bend toward the normal.

b) We will identify air as medium 1 and the fiber as medium 2.

Thus, $n_1 = 1.00$ (index of air), $n_2 = 1.44$ and $\theta_1 = 22^\circ$

$$n_1 \sin \theta_1 = n_2 \sin \theta_2 \quad \sin 22 = 1.44 \sin \theta_2 \quad \sin \theta_2 = \frac{\sin 22}{1.44}$$

$$\theta_2 = \sin^{-1}(0.26) \Rightarrow \theta_2 = 15^\circ$$

c) The path of the light is shown in the figure below

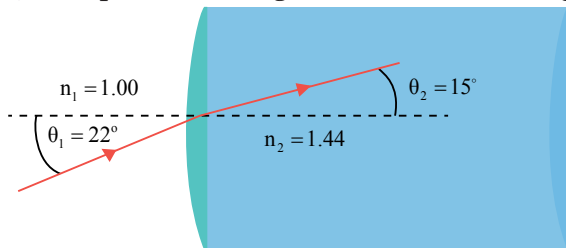

Example 1.29

A ray of light is incident through glass, with refractive index 1.52, on an interface separating glass and water with refractive index 1.32. What is the angle of refraction if the angle of incidence of the ray in glass is 25° ?

Solution

Let the needed angle be t , use Snell's law to write:

$$1.52 \sin 25^\circ = 1.32 \sin t$$

$$\Leftrightarrow \sin t = \frac{1.52 \sin 25^\circ}{1.32}$$

$$t = \sin^{-1} \left(\frac{1.52 \sin 25^\circ}{1.32} \right)$$

$$\Rightarrow t = 29.1^\circ$$

Unit Summary

1. The addition and subtraction formulae

$$\cos(x+y) = \cos x \cos y - \sin x \sin y \quad \tan(x+y) = \frac{\tan x + \tan y}{1 - \tan x \tan y}$$

$$\cos(x-y) = \cos x \cos y + \sin x \sin y \quad \tan(x-y) = \frac{\tan x - \tan y}{1 + \tan x \tan y}$$

$$\sin(x+y) = \sin x \cos y + \cos x \sin y$$

$$\sin(x-y) = \sin x \cos y - \cos x \sin y \quad \cot(x+y) = \frac{\cot x \cot y - 1}{\cot y + \cot x}$$

$$\cot(x-y) = \frac{\cot x \cot y + 1}{\cot y - \cot x}$$

2. The double angle formulae

$$\sin 2x = 2 \sin x \cos x$$

$$\cos 2x = \cos^2 x - \sin^2 x$$

$$= 1 - 2 \sin^2 x$$

$$= 2 \cos^2 x - 1$$

$$\tan 2x = \frac{2 \tan x}{1 - \tan^2 x} \quad \text{only one sign + or - is chosen depending on the quadrant in which } \frac{x}{2} \text{ lies}$$

$$\cot 2x = \frac{\cot^2 x - 1}{2 \cot x}$$

3. The half angle formulae

$$\sin \frac{x}{2} = \pm \sqrt{\frac{1 - \cos x}{2}}$$

$$\cos \frac{x}{2} = \pm \sqrt{\frac{\cos x + 1}{2}}$$

$$\tan \frac{x}{2} = \pm \sqrt{\frac{1 - \cos x}{1 + \cos x}}$$

$$= \frac{1 - \cos x}{\sin x}$$

$$= \frac{\sin x}{1 + \cos x}$$

4. The formulae for transforming product in sum

$$\cos x \cos y = \frac{1}{2} [\cos(x+y) + \cos(x-y)]$$

$$\sin x \sin y = -\frac{1}{2} [\cos(x+y) - \cos(x-y)]$$

$$\sin x \cos y = \frac{1}{2} [\sin(x+y) + \sin(x-y)]$$

$$\cos x \sin y = \frac{1}{2} [\sin(x+y) - \sin(x-y)]$$

5. The formulae for transforming sum in product

$$\cos p + \cos q = 2 \cos \frac{p+q}{2} \cos \frac{p-q}{2}$$

$$\cos p - \cos q = -2 \sin \frac{p+q}{2} \sin \frac{p-q}{2}$$

$$\sin p + \sin q = 2 \sin \frac{p+q}{2} \cos \frac{p-q}{2}$$

$$\sin p - \sin q = 2 \cos \frac{p+q}{2} \sin \frac{p-q}{2}$$

6. When solving trigonometric equation or inequality, try to transform or rearrange and rewrite the given expression using trigonometric identities to remain with a simple equation or inequality. Simple equation or inequality involves one trigonometric function with one unknown, like $\sin x = \frac{1}{2}$.

7. When solving the equation $a \sin x + b \cos x = c$, we divide each side by a and we let $\tan \alpha = \frac{b}{a} \Rightarrow \alpha = \tan^{-1} \left(\frac{b}{a} \right)$

8. When solving inequalities, first replace the inequality sign with equal sign and then solve. Find all non equivalent angles in $[0, 2\pi]$. Place these angles on a trigonometric circle. They will divide the circle into arcs. Choose the arcs containing the angles corresponding to the given inequality.

End of Unit Assessment

- Express $\tan 4x$ in function of tangent.
- Express $\cot 4x$ in function of cotangent.
- Given that θ is acute and $\sin \theta = \frac{5}{13}$, find the exact value of $\sin 2\theta$.
- Prove the identity $\cot a - \tan a = 2 \cot 2a$
- Find, without using calculator, the exact value of
 - $2 \sin 75^\circ \cos 75^\circ$
 - $\cos^2\left(\frac{45^\circ}{2}\right) - \sin^2\left(\frac{45^\circ}{2}\right)$
 - $\frac{2 \tan\left(\frac{135^\circ}{2}\right)}{1 - \tan^2\left(\frac{135^\circ}{2}\right)}$
 - $1 - 2 \sin^2 15^\circ$
- If $\cos \theta = \frac{3}{5}$ and θ is acute, find the exact value of $\cos 2\theta$
- If $\tan \theta = \frac{12}{5}$ and θ is acute, find the exact value of $\tan 2\theta$
- Transform in product
 - $\cos 8x - \cos 9x$
 - $\sin 3x + \sin 11x$
- Transform in sum
 - $\sin 4x \cos 11x$
 - $\cos 7x \sin 9x$
- Solve the following equations:
 - $(2 \sin x - 1)(\tan x - 1) = 0$ for $0 \leq x \leq \pi$
 - $\cos 2x \cos x - \sin 2x \sin x = 0$ for $0 \leq x \leq 2\pi$

In number 11-27, solve the given equation for $0^\circ \leq \theta \leq 360^\circ$, giving θ to 1 decimal place where appropriate

- $\cos(\theta - 45^\circ) = \frac{1}{\sqrt{3}} \cos \theta$
- $\sin(\theta + 30^\circ) = 2 \cos \theta$
- $2 \cos(\theta - 60^\circ) = \sin \theta$
- $\sin(\theta + 15^\circ) = 3 \cos(\theta - 15^\circ)$
- $2 \sin \theta \cos \theta = 1 - 2 \sin^2 \theta$
- $\sin 2\theta + \sin \theta - \tan \theta = 0$
- $\sin 2\theta + \sin \theta = 0$
- $\cos 2\theta = 2 \sin \theta$
- $\tan 2\theta + \tan \theta = 0$
- $3 \cos^2 \theta - 2 \sin \theta - 2 = 0$

- | | |
|--|---|
| 21. $3\sec^2 \theta + 1 = 8 \tan \theta$ | 22. $2 + \cos \theta \sin \theta = 8 \sin^2 \theta$ |
| 23. $\sin 2\theta = \cos \theta$ | 24. $3 \cos 2\theta - 7 \cos \theta - 2 = 0$ |
| 25. $\sec^2 \theta = 4 \tan \theta$ | 26. $2 \sin 2\theta = \tan \theta$ |
| 27. $\sin 2\theta - \tan \theta = 0$ | |

In number 28-33, solve the given equations for all values of x from -180° to 180°

- | | |
|---------------------------------|---------------------------------------|
| 28. $4 - \sin x = 4 \cos^2 x$ | 29. $\sin^2 x + \cos x + 1 = 0$ |
| 30. $5 - 5 \cos x = 3 \sin^2 x$ | 31. $8 \tan x = 3 \cos x$ |
| 32. $\sin^2 x + 5 \cos^2 x = 3$ | 33. $1 - \cos^2 x = -2 \sin x \cos x$ |

In number 34-42, solve the given equations for all values of θ from 0° to 360°

- | | |
|---|---|
| 34. $\sec \theta = 2$ | 35. $\cot 2\theta = -\frac{2}{5}$ |
| 36. $3 \cot \theta = \tan \theta$ | 37. $2 \sin \theta = -3 \cot \theta$ |
| 38. $2 \sec^2 \theta - 3 + \tan \theta = 0$ | 39. $2 \tan \theta = 3 + 5 \cot \theta$ |
| 40. $4 \cot \theta + 15 \sec \theta = 0$ | 41. $\csc^2 \theta = 3 \cot \theta - 1$ |
| 42. $2 \tan \theta = 5 \csc \theta + \cot \theta$ | |

In number 43-45, solve the given inequalities

- | | |
|-------------------|---------------------------------------|
| 43. $\sin 5x < 0$ | 44. $\cos 3x \leq \frac{\sqrt{3}}{2}$ |
|-------------------|---------------------------------------|
45. $\frac{2 \cos x - 1}{2 \cos x + 1} < 0$ for $0 \leq x \leq 2\pi$
46. A weight is attached to a spring and reaches its equilibrium position ($x = 0$). It is then set in motion resulting in a displacement of $x = 10 \cos t$. Find the spring's displacement when $t = 0$, $t = \frac{\pi}{3}$ and $t = \frac{3\pi}{4}$
47. Assume that a particle's position on the x -axis is given by $x = 3 \cos t + 4 \sin t$, where x is measured in metres and t is measured in seconds. Find the particle's position when $t = 0$, $t = \frac{\pi}{2}$ and $t = \pi$

Unit 2

Sequences

Introductory activity

Suppose that an insect population is growing in such a way that each new generation is 2 times as large as the previous generation. If there are 126 insects in the first generation, on a piece of paper, write down the number of insects that will be there in second, third, fourth, ... n th generation.

There is an order in the numbers of insects of different generations that is, we actually have the first number, the second number and so on. A sequence is a set of real numbers with a natural order.

2. Objectives

By the end of this unit, a student will be able to:

- ⦿ Define a sequence and determine whether a given sequence can be divergent or convergent.
- ⦿ Identify an arithmetic, a harmonic or a geometric sequence.
- ⦿ Determine n^{th} term and the sum of the first n terms of an arithmetic or geometric sequence.
- ⦿ Apply the concepts of sequences to solve problems involving arithmetic, harmonic or geometric sequence.

2.1. Generalities on sequences

2.1.1. Definitions



Activity 2.1

Suppose that you want to build a tower with blocks.

- On a piece of paper, draw that tower starting with 15 blocks for the bottom row until you are not able to add another row.
- How many rows are there?
- Write down the number of blocks that are in each row (from bottom row to the top row).
- In the numbers written down, each number can be found by adding a constant number to the previous. Guess that constant number.

Hint: see the following picture

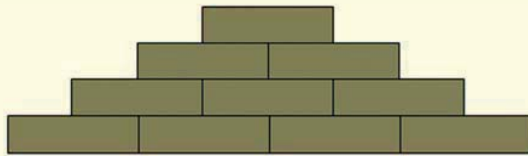

From Activity 2.1, we obtained three patterns of numbers following the given rules. Each pattern of numbers obtained in this activity is called **numerical sequence**.

Numbers in sequence are denoted $u_1, u_2, u_3, \dots, u_{n-1}, u_n, \dots$ and shortly $\{u_n\}$. We can also write $\{u_1, u_2, u_3, \dots, u_{n-1}, u_n, \dots\}$. The dots are used to suggest that the sequence continues indefinitely, following the obvious pattern. The numbers $u_1, u_2, u_3, \dots, u_{n-1}, u_n, \dots$ in a sequence are called **terms of the sequence**. The natural number, n , is called **term number** and value u_n is called **a general term of a sequence** and the term u_1 is the **initial term**.

As a sequence continues indefinitely, it can be denoted as $\{u_n\}_{n=1}^{+\infty}$.

The number of terms of a sequence (possibly infinite) is called the **length of the sequence**.



Notice

- ⦿ Sometimes, the term number, n , starts from 0. In this case, terms of a sequence are $u_0, u_1, u_2, \dots, u_{n-1}, u_n, \dots$ and this sequence is denoted by $\{u_n\}_{n=0}^{+\infty}$. In this case, the initial term is u_0 .
- ⦿ A sequence can be finite, like the sequence $2, 4, 8, 16, \dots, 256$.
- ⦿ Finite sequences are sometimes known as **strings** or **words** and infinite sequences as **streams**.

The empty sequence $\{ \}$ is included in most notions of sequences but may be excluded depending on the context.

Usually, a numerical sequence is given by some formula $u_n = f(n)$, permitting to find any term of the sequence by its number n ; this formula is called a **general term formula**.

This suggests the definition that a sequence (or **infinite sequence**) is a function whose domain is the set of positive integers.

Note that it is not always possible to give the numerical sequence by a general term formula; sometimes a sequence is given by description of its terms.

Example 2.1

Numerical sequences:

- a) $1, 2, 3, 4, 5, \dots$ a sequence of natural numbers.
- b) $2, 4, 6, 8, 10, \dots$ a sequence of even numbers.
- c) $1.4, 1.41, 1.414, 1.4142, \dots$ a numerical sequence of approximate, defined more precisely values of $\sqrt{2}$.

For the last sequence, it is impossible to give a general term formula, nevertheless, this sequence is described completely.

Example 2.2

List the first five terms of the sequence $\{2^n\}_{n=1}^{+\infty}$

Solution

Here, we substitute $n = 1, 2, 3, 4, 5$ into the formula 2^n . This gives $2^1, 2^2, 2^3, 2^4, 2^5, \dots$

Or, equivalently, $2, 4, 8, 16, 32, \dots$

Example 2.3

Express the following sequences in general notation

$$\text{a) } \frac{1}{2}, \frac{2}{3}, \frac{3}{4}, \frac{4}{5}, \dots \quad \text{b) } \frac{1}{2}, \frac{1}{4}, \frac{1}{8}, \frac{1}{16}, \dots$$

Solution

$$\text{a) } \frac{1}{2}, \frac{2}{3}, \frac{3}{4}, \frac{4}{5}, \dots$$

Beginning by comparing terms and term numbers:

Term number	1	2	3	4	...
Term	$\frac{1}{2}$	$\frac{2}{3}$	$\frac{3}{4}$	$\frac{4}{5}$...

In each term, the numerator is the same as the term number, and the denominator is one greater the term number.

Thus, the n^{th} term is $\frac{n}{n+1}$ and the sequence may be written as

$$\left\{ \frac{n}{n+1} \right\}_{n=1}^{+\infty}$$

$$\text{b) } \frac{1}{2}, \frac{1}{4}, \frac{1}{8}, \frac{1}{16}, \dots$$

Beginning by comparing terms and term numbers:

Term number	1	2	3	4	...
Term	$\frac{1}{2}$	$\frac{1}{4}$	$\frac{1}{8}$	$\frac{1}{16}$...

Or

Term number	1	2	3	4	...
Term	$\frac{1}{2^1}$	$\frac{1}{2^2}$	$\frac{1}{2^3}$	$\frac{1}{2^4}$...

In each term, the denominator is equal to 2 powers the term number. We observe that the n^{th} term is $\frac{1}{2^n}$ and the sequence may be written as $\left\{ \frac{1}{2^n} \right\}_{n=1}^{+\infty}$.

Example 2.4

A sequence is defined by

$$\{u_n\} : \begin{cases} u_0 = 1 \\ u_{n+1} = 3u_n + 2 \end{cases}$$

Determine u_1 , u_2 and u_3

Solution

Since $u_0 = 1$ and $u_{n+1} = 3u_n + 2$, replace n with 0, 1, 2 to obtain u_1, u_2, u_3 respectively.

$$\begin{aligned} n = 0, \quad u_{0+1} = u_1 &= 3u_0 + 2 \\ &= 3 \times 1 + 2 \\ &= 5 \end{aligned}$$

$$\begin{aligned} n = 1, \quad u_{1+1} = u_2 &= 3u_1 + 2 & n = 2, \quad u_{2+1} = u_3 &= 3u_2 + 2 \\ &= 3 \times 5 + 2 & &= 3 \times 17 + 2 \\ &= 17 & &= 53 \end{aligned}$$

Thus,

$$\begin{cases} u_1 = 5 \\ u_2 = 17 \\ u_3 = 53 \end{cases}$$

Application Activity 2.1

1. A sequence is given by $\{u_n\} : \begin{cases} u_0 = 1 \\ u_n = \frac{2n^2}{n^2 + 1} \end{cases}$
Determine u_1, u_2 and u_3

2. List the first five terms of the sequence $\left\{ \sqrt{n+1} - \sqrt{n} \right\}_{n=1}^{+\infty}$

3. Express the following sequence in general notation

$$1, 3, 5, 7, 9, 11, \dots$$

2.1.2. Convergent and divergent sequences



Activity 2.2

As n tends to plus infinity, each of the following sequences will tend to which value?

1. $\left\{ \frac{3n^2 - 1}{n^3} \right\}$

2. $\left\{ \sqrt{n+1} - \sqrt{n} \right\}$

3. $\{n^2\}$

A numerical sequence is said to be **convergent** if the limit exists at $+\infty$ whereas if the limit at $+\infty$ does not exist (or is infinity), the sequence is said to be **divergent**. A number L is called **the limit** of a numerical sequence $\{u_n\}$ if $\lim_{n \rightarrow +\infty} u_n = L$

Example 2.5

Determine whether the sequence $\left\{ \frac{n}{2n+1} \right\}_{n=1}^{+\infty}$ converges or diverges.

Solution

First, we find the limit of this sequence as n tends to infinity

$$\begin{aligned} \lim_{n \rightarrow +\infty} \frac{n}{2n+1} &= \lim_{n \rightarrow +\infty} \frac{n}{n \left(2 + \frac{1}{n} \right)} \\ &= \lim_{n \rightarrow +\infty} \frac{1}{2 + \frac{1}{n}} \end{aligned}$$

$$= \frac{1}{2}$$

Thus, $\left\{ \frac{n}{2n+1} \right\}_{n=1}^{+\infty}$ converges to $\frac{1}{2}$.

Example 2.6

Determine whether the sequence $\{8 - 2n\}_{n=1}^{+\infty}$ converges or diverges.

Solution

First, we find the limit of this sequence as n tends to infinity

$$\lim_{n \rightarrow +\infty} (8 - 2n) = 8 - 2(+\infty)$$

$$= -\infty$$

Thus, $\{8 - 2n\}_{n=1}^{+\infty}$ **diverges**.

Application Activity 2.2

Which of the sequences converge, and which ones diverge? Find the limit of each convergent sequence.

- | | | |
|----------------------|--|---|
| 1. $\{2 + (0.1)^n\}$ | 2. $\left\{\frac{1-2n}{1+2n}\right\}$ | 3. $\left\{\frac{1-5n^4}{n^4+8n^3}\right\}$ |
| 4. $\{(-1)^n\}$ | 5. $\left\{\frac{2n}{\sqrt{3n+1}}\right\}$ | 6. $\frac{\sqrt{7n^2+2}}{n^3+8}$ |

2.1.3. Monotone sequences



Activity 2.3

For each of the following sequences, state whether the terms are in ascending, descending, both or neither order

- | | |
|--------------------------|--|
| 1. 1, 2, 3, 4, 5, 6, ... | 2. $1, \frac{1}{2}, \frac{1}{4}, \frac{1}{8}, \dots$ |
| 3. 1, -1, 1, -1, 1, ... | 4. 2, 2, 2, 2, 2, 2, ... |

A sequence $\{u_n\}$ is said to be

- ⊙ **increasing** or in **ascending** order if $u_1 < u_2 < u_3 < \dots < u_n < \dots$
- ⊙ **non-decreasing** if $u_1 \leq u_2 \leq u_3 \leq \dots \leq u_n \leq \dots$
- ⊙ **decreasing** or in **descending** order if $u_1 > u_2 > u_3 > \dots > u_n > \dots$
- ⊙ **non-increasing** if $u_1 \geq u_2 \geq u_3 \geq \dots \geq u_n \geq \dots$

A sequence that is either non-decreasing or non-increasing is called **monotone**, and a sequence that is increasing or decreasing is called **strictly monotone**. Observe that a strictly monotone sequence is monotone, but not conversely.

In order, for a sequence to be **increasing**, all pairs of successive terms, u_n and u_{n+1} , must satisfy $u_n < u_{n+1}$, or equivalently, $u_n - u_{n+1} < 0$.

More generally, monotone sequences can be classified as follows:

Difference between successive terms	Classification
$u_n - u_{n+1} < 0$	Increasing
$u_n - u_{n+1} > 0$	Decreasing
$u_n - u_{n+1} \leq 0$	Non-decreasing
$u_n - u_{n+1} \geq 0$	Non-increasing

If the terms in the sequence are all positive, then we can divide both sides of the inequality $u_n < u_{n+1}$ by u_n to obtain $1 < \frac{u_{n+1}}{u_n}$ or equivalently $\frac{u_{n+1}}{u_n} > 1$.

More, generally, monotone sequences with positive terms can be classified as follows:

Difference between successive terms	Classification
$\frac{u_{n+1}}{u_n} > 1$	Increasing
$\frac{u_{n+1}}{u_n} < 1$	Decreasing
$\frac{u_{n+1}}{u_n} \geq 1$	Non-decreasing
$\frac{u_{n+1}}{u_n} \leq 1$	Non-increasing

Example 2.7

Prove that the sequence $\frac{1}{2}, \frac{2}{3}, \frac{3}{4}, \dots, \frac{n}{n+1}, \dots$ is an increasing sequence.

Solution

Here, $u_n = \frac{n}{n+1}$ and $u_{n+1} = \frac{n+1}{n+2}$

Thus, for $n \geq 1$

$$\begin{aligned}
 u_n - u_{n+1} &= \frac{n}{n+1} - \frac{n+1}{n+2} \\
 &= \frac{n^2 + 2n - n^2 - 2n - 1}{(n+1)(n+2)} \\
 &= -\frac{1}{(n+1)(n+2)} < 0
 \end{aligned}$$

This proves that the given sequence is **increasing**.

Alternative method

We can show that the sequence $\frac{1}{2}, \frac{2}{3}, \frac{3}{4}, \dots, \frac{n}{n+1}, \dots$ is increasing by examining the ratio of successive terms as follows:

$$\begin{aligned}
 \frac{u_{n+1}}{u_n} &= \frac{\frac{n+1}{n+2}}{\frac{n}{n+1}} \\
 &= \frac{n+1}{n+2} \times \frac{n+1}{n} \\
 &= \frac{n^2 + 2n + 1}{n^2 + 2n}
 \end{aligned}$$

Since the numerator exceeds the denominator, the ratio exceeds 1, that is, $\frac{u_{n+1}}{u_n} > 1$ for $n \geq 1$. This proves that the sequence is increasing.

Example 2.8

The sequence 4, 4, 4, 4, ... is both non-decreasing and non-increasing.

Example 2.9

The sequence -2, 2, -2, 2, -2, ... is not monotonic.

Application Activity 2.3

Which of the following sequences are in increasing, decreasing, non-increasing, non-decreasing, not monotonic

- 1, 2, 3, ..., n, ...
- $\left\{ \frac{n}{n+1} \right\}$
- $\left\{ \frac{1}{2^n} \right\}$
- 3, 3, 3, 3, ...
- 1, -1, 1, -1, ...

2.2. Arithmetic and harmonic sequences

2.2.1. Definition

Activity 2.4



In each of the following sequences, each term can be found by adding a constant number to the previous one. Guess that constant number.

1. $\{3n + 2\}$ 2. $\{16 - 6n\}$

Sequences of numbers that follow a pattern of adding a fixed number from one term to the next are called **arithmetic sequences** or **arithmetic progressions**.

Example 2.10

The following sequences are arithmetic sequences:

Sequence $\{u_n\}$: 5, 8, 11, 14, 17, ...

Sequence $\{v_n\}$: 26, 31, 36, 41, 46, ...

Sequence $\{w_n\}$: 20, 18, 16, 14, 12, ...

Common difference

The fixed numbers that bind each sequence together are called the **common differences**. Sometimes mathematicians use the letter d when referring to these types of sequences.

d can be calculated by subtracting any two consecutive terms in an arithmetic sequence. That is $d = u_{n+1} - u_n$ or $d = u_n - u_{n-1}$.

Notice

If three consecutive terms are in arithmetic sequence, the double of the middle term is equal to the sum of extreme terms. That is, for an arithmetic sequence u_{n-1}, u_n, u_{n+1} , we have $2u_n = u_{n-1} + u_{n+1}$.

Example 2.11

4, 6, 8 are three consecutive terms of an arithmetic sequence because $2 \times 6 = 8 + 4 \Leftrightarrow 12 = 12$.

Example 2.12

If $\frac{1}{a+b}, \frac{1}{a+c}, \frac{1}{b+c}$ are 3 consecutive terms of an arithmetic progression, show that it will be the same for a^2, b^2, c^2 .

Solution

If $\frac{1}{a+b}, \frac{1}{a+c}, \frac{1}{b+c}$ are 3 consecutive terms of an arithmetic

progression, then

$$\frac{2}{a+c} = \frac{1}{a+b} + \frac{1}{b+c}$$

$$\Leftrightarrow \frac{2}{a+c} = \frac{2b+c+a}{(a+b)(b+c)}$$

$$\Leftrightarrow 2(ab+ac+b^2+bc) = (a+c)(2b+a+c)$$

$$\Leftrightarrow 2ab+2ac+2b^2+2bc = 2ab+a^2+ac+2bc+ac+c^2$$

$$\Leftrightarrow 2b^2 = a^2 + c^2$$

Also a^2, b^2, c^2 are 3 consecutive terms of an arithmetic progression if $2b^2 = a^2 + c^2$.

Thus, if $\frac{1}{a+b}, \frac{1}{a+c}, \frac{1}{b+c}$ are 3 consecutive terms of an arithmetic progression, it will be the same for a^2, b^2, c^2 .

Example 2.13

Form an arithmetic progression of three numbers such that the sum of its terms is 30 and the sum of the squares of its terms is 332.

Solution

Let the second term be x . The first term is $x-d$ and the third term is $x+d$ where d is the common difference.

$$\text{Now, } x-d+x+x+d = 30 \Rightarrow 3x = 30 \text{ or } x = 10$$

$$\text{Also, } (x-d)^2 + x^2 + (x+d)^2 = 332$$

$$\text{Or } (10-d)^2 + 100 + (10+d)^2 = 332$$

$$\text{Or } 2d^2 = 32 \Rightarrow d = \pm 4$$

Therefore the progression is 6, 10, 14 or 14, 10, 6

Example 2.14

Calculate x so that the squares of $1+x$, $q+x$, and q^2+x will be three consecutive terms of an arithmetic progression where q is any given number.

Solution

We need to find x such that $(1+x)^2$, $(q+x)^2$, and $(q^2+x)^2$ form an arithmetic progression.

$$2(q+x)^2 = (1+x)^2 + (q^2+x)^2$$

$$\Leftrightarrow 2(q^2 + 2qx + x^2) = 1 + 2x + x^2 + q^4 + 2xq^2 + x^2$$

$$\Leftrightarrow 2q^2 + 4qx + 2x^2 = 1 + 2x + x^2 + q^4 + 2xq^2 + x^2$$

$$\Leftrightarrow 2q^2 + 4qx = 1 + 2x + q^4 + 2xq^2$$

$$\Leftrightarrow 4qx - 2x - 2xq^2 = 1 - 2q^2 + q^4$$

$$\Leftrightarrow x(4q - 2 - 2q^2) = (1 - q^2)^2$$

$$\Leftrightarrow x = \frac{(1 - q^2)^2}{-2(1 - 2q + q^2)}$$

$$\Leftrightarrow x = \frac{(1 - q)^2(1 + q)^2}{-2(1 - q)^2}$$

$$\Leftrightarrow x = \frac{(1 + q)^2}{-2}$$

Thus, $x = \frac{-(1+q)^2}{2}$, if $q \neq 1$

If $q = 1$, then x is any real number,

$(1+x)^2; (1+x)^2; (1+x)^2$ is a constant arithmetic sequence with common difference 0.

Application Activity 2.4

1. Find x such that 6, x , 12 are in arithmetic progression.
2. Is the sequence 2, 7, 12, 17, 23, 27 arithmetic progression? Why?
3. Determine the common difference of the sequence $\{2n+1\}$

4. Given that 24 , $5x+1$, x^2-1 are three consecutive terms of an arithmetic progression, find the values of x and the numerical value of the fourth term for each value of x found.

2.2.2. General term of an arithmetic sequence



Activity 2.5

If $\{u_n\}$ is an arithmetic sequence with common difference d and initial term u_1 , then

$$u_2 = u_1 + d$$

$$u_3 = u_2 + d = (u_1 + d) + d = u_1 + 2d$$

Continue in this manner up to u_{10} and conclude whether the general formula could be used for u_n

From Activity 2.5, the n^{th} term, u_n , of an arithmetic sequence $\{u_n\}$ with common difference d and initial term u_1 is given by

$$u_n = u_1 + (n-1)d$$

Generally, if u_p is any p^{th} term of a sequence, then the n^{th} term is given by $u_n = u_p + (n-p)d$

Example 2.15

If the first and tenth terms of an arithmetic sequence are 3 and 30 respectively, find the fiftieth term of the sequence.

Solution

$$u_1 = 3 \text{ and } u_{10} = 30$$

$$\text{But } u_n = u_1 + (n-1)d, \quad u_{10} = u_1 + (10-1)d$$

$$\text{Then } 30 = 3 + (10-1)d \Leftrightarrow 30 = 3 + 9d \Rightarrow d = 3$$

$$\text{Now, } u_{50} = u_1 + (50-1)d = 3 + 49 \times 3 = 150$$

Thus, the fiftieth term of the sequence is 150.

Example 2.16

If the 3rd term and the 8th term of an arithmetic sequence are 5 and 15 respectively, find the common difference.

Solution

$$u_3 = 5, u_8 = 15$$

Using the general formula: $u_n = u_p + (n - p)d$

$$u_3 = u_8 + (3 - 8)d$$

$$5 = 15 - 5d$$

$$\Leftrightarrow 5d = 15 - 5$$

$$\Rightarrow 5d = 10 \Rightarrow d = 2$$

The common difference is 2.

Example 2.17

Consider the sequence 5, 8, 11, 14, 17, ..., 47. Find the number of terms in this sequence

Solution

We see that $u_1 = 5$, $u_n = 47$ and $d = 3$.

But we know that $u_n = u_1 + (n - 1)d$. This gives

$$47 = 5 + (n - 1)3$$

$$\Leftrightarrow 42 = 3n - 3 \Rightarrow n = 15$$

This means that there are 15 terms in the sequence.

Example 2.18

Consider the sequence which went from 20 to -26 with -2 as common difference. Find the number of terms.

Solution

We have

$$-26 = 20 + (n - 1)(-2)$$

$$\Leftrightarrow -46 = -2n + 2 \Rightarrow n = 24$$

This means that there are 24 terms in the sequence.

Application Activity 2.5

1. If the 2nd term and the 6th term of an arithmetic sequence are 4 and 16 respectively, find the common difference.
2. Find the number of terms in the sequence 1, 4, 7, 10, ..., 25.

3. A sequence (a_n) is given by $a_n = n^2 - 1, n \in \mathbb{N}$. Show that (a_n) is not an arithmetic sequence.
4. The m^{th} term of arithmetic progression is $\frac{1}{n}$ and n^{th} term is $\frac{1}{m}$; find mn^{th} term.
5. A body falls 16 metres in the first second of its motion, 48 metres in the second, 80 metres in the third, 112 metres in the fourth and so on. How far does it fall during the 11th second of its motion?
6. The 9th term of arithmetic progression is 499 and 499th term is 9. The term which is equal to zero is
 - i) 501st
 - ii) 502nd
 - iii) 504th
 - iv) None of these answers

2.2.3. Arithmetic means

Activity 2.6



Suppose that you need to form an arithmetic sequence of 7 terms such that the first term is 2 and the seventh term is 20. Write down that sequence.

If three or more than three numbers are in arithmetic sequence, then all terms lying between the first and the last numbers are called **arithmetic means**. If B is arithmetic

mean between A and C , then $B = \frac{A+C}{2}$.

To insert k terms called **arithmetic means** between two terms u_1 and u_n is to form an arithmetic sequence of $n = k + 2$ terms whose first term is u_1 and the last term is u_n .

While there are several methods, we will use our n^{th} term formula $u_n = u_1 + (n-1)d$.

As u_1 and u_n are known, we need to find the common difference d taking $n = k + 2$ where k is the number of terms to be inserted.

Example 2.19

Insert three arithmetic means between 7 and 23.

Solution

Here $k = 3$ and then $n = k + 2 = 5$, $u_1 = 7$ and $u_n = u_5 = 23$.

Then

$$u_5 = u_1 + (5-1)d$$

$$\Leftrightarrow 23 = 7 + 4d \Rightarrow d = 4$$

Now, insert the terms using $d = 4$, the sequence is 7, 11, 15, 19, 23.

Example 2.20

Insert five arithmetic means between 2 and 20.

Solution

Here $k = 5$ and then $n = k + 2 = 7$, $u_1 = 2$ and $u_n = u_7 = 20$.

Then

$$u_7 = u_1 + (7-1)d$$

$$\Leftrightarrow 20 = 2 + 6d \Rightarrow d = 3$$

Now, insert the terms using $d = 3$, the sequence is 2, 5, 8, 11, 14, 17, 20.

Application Activity 2.6

1. Insert 4 arithmetic means between -3 and 7
2. Insert 9 arithmetic means between 2 and 32
3. Between 3 and 54, n terms have been inserted in such a way that the ratio of 8th mean and $(n-2)$ th mean is $\frac{3}{5}$. Find the value of n .
4. There are n arithmetic means between 3 and 54 terms such that 8th mean is equal to $(n-1)$ th mean as 5 to 9. Find the value of n .
5. Find the value of n so that $\frac{a^{n+1} + b^{n+1}}{a^n + b^n}$ will be the arithmetic mean between a and b .

2.2.4. Arithmetic series

Activity 2.7



Consider a finite arithmetic sequence $\{u_n\} = u_1, u_2, u_3, \dots, u_n$ with common difference d . Let s_n denote the sum of these terms. We have;

$$u_1 = u_1$$

$$u_2 = u_1 + d$$

$$\vdots$$

$$u_{n-1} = u_1 + (n-2)d$$

$$u_n = u_1 + (n-1)d$$

Sum up these terms and give the expression of s_n

For finite arithmetic sequence $\{u_n\} = u_1, u_2, u_3, \dots, u_n$, the sum $\sum_{r=1}^n u_r = u_1 + u_2 + u_3 + \dots + u_n$ is called an arithmetic series.

We denote the sum of the first n terms of the sequence by S_n .

$$\text{Thus, } S_n = u_1 + u_2 + u_3 + \dots + u_n = \sum_{r=1}^n u_r$$

From Activity 2.7, the sum of the first n terms of a finite arithmetic sequence with initial term u_1 is given by $S_n = \frac{n}{2}(u_1 + u_n)$

If the initial term is u_0 , the formula becomes $S_n = \frac{n+1}{2}(u_0 + u_n)$

Example 2.21

Calculate the sum of first 100 terms of the sequence 2, 4, 6, 8, ...

Solution

We see that the common difference is 2 and the initial term is $u_1 = 2$. We need to find $u_n = u_{100}$.

$$\begin{aligned} u_{100} &= 2 + (100-1)2 \\ &= 2 + 198 \\ &= 200 \end{aligned}$$

Now,

$$\begin{aligned} S_{100} &= \frac{100}{2}(u_1 + u_{100}) \\ &= 50(2 + 200) \\ &= 10100 \end{aligned}$$

Example 2.22

Find the sum of first k even integers ($k \neq 0$).

Solution

$$u_1 = 0 \text{ and } d = 2$$

$$u_n = u_k$$

$$u_k = 0 + (k - 1)2$$

$$u_k = 2(k - 1)$$

$$S_k = \frac{k}{2}(0 + 2k - 2)$$

$$S_k = k(k - 1)$$

Application Activity 2.7

1. Consider the arithmetic sequence 8, 12, 16, 20, ... Find the expression for S_n .
2. Sum the first twenty terms of the sequence 5, 9, 13, ...
3. The sum of the terms in the sequence 1, 8, 15, ... is 396. How many terms does the sequence contain?

2.2.5. Harmonic sequences

Activity 2.8



Consider the following arithmetic sequence: 2, 4, 6, 8, 10, 12, 14, 16.

Form another sequence whose terms are the reciprocals of the terms of the given sequence. What can you say about the new sequence?

Harmonic sequence is a sequence of numbers in which the

reciprocals of the terms are in arithmetic sequence.

Example 2.23

Example of harmonic sequence is $\frac{1}{3}, \frac{1}{6}, \frac{1}{9}, \dots$

If you take the reciprocal of each term from the above harmonic sequence, the sequence will become 3, 6, 9, ... which is an arithmetic sequence with a common difference of 3.

Example 2.24

Another example of harmonic sequence is 6, 3, 2. The reciprocals of each term are $\frac{1}{6}, \frac{1}{3}, \frac{1}{2}$ which is an arithmetic sequence with a common difference of $\frac{1}{6}$.

Remark

To determine whether a given sequence is harmonic or not, consider the sequence formed by the reciprocals of the terms. If this new sequence is arithmetic, then the initial sequence is harmonic

Example 2.25

The 2nd term of a harmonic progression is $\frac{1}{6}$ and 6th term is $-\frac{1}{6}$. Find the 20th term and nth term.

Solution

In harmonic progression, $h_2 = \frac{1}{6}$ and $h_6 = -\frac{1}{6}$.

Thus, in the corresponding arithmetic progression, $a_2 = 6$ and $a_6 = -6$

Or $a_6 = a_2 + 4d \Rightarrow 6 + 4d = -6$ or $d = -3$.

Hence, $a_{20} = 6 + 18(-3) = -48 \Rightarrow h_{20} = -\frac{1}{48}$

$a_n = 6 + (n-2)(-3) = 12 - 3n \Rightarrow h_n = \frac{1}{12-3n}$



Notice

Harmonic means

If three terms a, b, c are in harmonic progression, the middle one is said to be Harmonic mean between the other two and

$$b = \frac{2ac}{a+c}.$$

Example 2.26

Insert 4 harmonic means between $\frac{2}{3}$ and $\frac{6}{19}$

Solution

Let the four harmonic means be h_1, h_2, h_3, h_4 .

Then $\frac{2}{3}, h_1, h_2, h_3, h_4, \frac{6}{19}$ are in harmonic progression

$\Rightarrow \frac{3}{2}, \frac{1}{h_1}, \frac{1}{h_2}, \frac{1}{h_3}, \frac{1}{h_4}, \frac{19}{6}$ are in arithmetic progression

where $a_1 = \frac{3}{2}$ and $a_6 = \frac{19}{6}$

$a_6 = \frac{19}{6} \Leftrightarrow a_1 + 5d = \frac{19}{6}$ with d common difference.

$$\Rightarrow \frac{3}{2} + 5d = \frac{19}{6} \Leftrightarrow 5d = \frac{19}{6} - \frac{3}{2} \Leftrightarrow 5d = \frac{10}{6} \Rightarrow d = \frac{1}{3}$$

$$\Rightarrow \begin{cases} \frac{1}{h_1} = \frac{3}{2} + \frac{1}{3} = \frac{11}{6} \equiv 1^{\text{st}} \text{ term of arithmetic progression} \\ \frac{1}{h_2} = \frac{3}{2} + \frac{2}{3} = \frac{13}{6} \equiv 2^{\text{nd}} \text{ term of arithmetic progression} \\ \frac{1}{h_3} = \frac{3}{2} + \frac{3}{3} = \frac{15}{6} = \frac{5}{2} \equiv 3^{\text{rd}} \text{ term of arithmetic progression} \\ \frac{1}{h_4} = \frac{3}{2} + \frac{4}{3} = \frac{17}{6} \equiv 4^{\text{th}} \text{ term of arithmetic progression} \end{cases}$$

The four harmonic means are $\frac{6}{11}, \frac{6}{13}, \frac{2}{5}, \frac{6}{17}$

Example 2.27

Find the n^{th} term of the series $2\frac{1}{2} + 1\frac{7}{13} + 1\frac{1}{9} + \frac{20}{23} + \dots$

Solution

The given series is $\frac{5}{2} + \frac{20}{13} + \frac{10}{9} + \frac{20}{23}, \dots$

The reciprocal of the terms are $\frac{2}{5}, \frac{13}{20}, \frac{9}{10}, \frac{23}{20}, \dots$

They are in arithmetic progression with the first term $\frac{2}{5}$ and the common difference $\frac{13}{20} - \frac{2}{5} = \frac{1}{4}$

The given series are in arithmetic progression.

n^{th} term of arithmetic progression:

$$a_n = \frac{2}{5} + (n-1)\frac{1}{4} = \frac{8+5n-5}{20} = \frac{5n+3}{20}$$

Hence n^{th} term of the given harmonic progression is $h_n = \frac{1}{a_n}$ or

$$h_n = \frac{20}{5n+3}$$

The n^{th} term of the series $2\frac{1}{2} + 1\frac{7}{13} + 1\frac{1}{9} + \frac{20}{23} + \dots$ is $\frac{20}{5n+3}$

Application Activity 2.8

- Find the 4th and 8th term of the harmonic sequence 6, 4, 3, ...
- Insert two harmonic means between 3 and 10.
- If a, b, c are in harmonic progression, show that $\frac{a}{b+c}, \frac{b}{c+a}, \frac{c}{a+b}$ are also in harmonic progression.
- Find the term number of harmonic sequence $\frac{\sqrt{5}}{3}, \frac{\sqrt{5}}{4}, \frac{1}{\sqrt{5}}, \dots, \frac{\sqrt{5}}{13}$
- The harmonic mean between two numbers is 3 and the arithmetic mean is 4. Find the numbers.
- Find the n^{th} term of the series $4 + 4\frac{2}{7} + 4\frac{8}{13} + 5 + \dots$

2.3. Geometric sequences

2.3.1. Definition



Activity 2.9

Take a piece of paper with a square shape.

1. Cut it into two equal parts.
2. Write down a fraction corresponding to one part according to the original piece of paper.
3. Take one part obtained in step 2) and cut; repeat step 1) and then step 2).
4. Continue until you remain with a small piece of paper that you are not able to cut it into two equal parts.
5. Observe the sequence of numbers you obtained and give the relationship between any two consecutive numbers.

Sequences of numbers that follow a pattern of multiplying a fixed number from one term to the next are called **geometric sequences** or **geometric progression**.

Example 2.28

The following sequences are geometric sequences:

Sequence $\{u_n\}$: 5, 10, 20, 40, 80, ...

Sequence $\{v_n\}$: 2, 1, $\frac{1}{2}$, $\frac{1}{4}$, $\frac{1}{8}$, ...

Sequence $\{w_n\}$: 1, -2, 4, -8, 16, ...

Common ratio

We can examine these sequences to greater depth. We must know that the fixed numbers that bind each sequence together are called the common ratios, denoted by the letter r .

r can be calculated by dividing any two consecutive terms in a geometric sequence. That is

$$r = \frac{u_{n+1}}{u_n} \text{ or } r = \frac{u_n}{u_{n-1}} \text{ or } u_n = ru_{n-1}.$$

Note that if three terms are consecutive terms of a geometric sequence, the square of the middle term is equal to the product of extreme terms. That is, for a geometric sequence u_{n-1}, u_n, u_{n+1} , we have $u_n^2 = u_{n-1} \cdot u_{n+1}$

Example 2.29

6, 12, 24 are consecutive terms of a geometric sequence because $(12)^2 = 6 \times 24 \Leftrightarrow 144 = 144$

Example 2.30

Find b such that 8, b , 18 will be in geometric sequence.

Solution

$$b^2 = 8 \times 18 = 144$$

$$b = \pm\sqrt{144} = \pm 12$$

Thus, 8, 12, 18 or 8, -12, 18 are in geometric sequence.

Example 2.31

The product of three consecutive numbers in geometric progression is 27. The sum of the first two and nine times the third is -79. Find the numbers.

Solution

Let the three terms be $\frac{x}{a}, x, ax$.
The product of the numbers is 27. So, $\frac{x}{a} \cdot x \cdot ax = 27 \Rightarrow x^3 = 27 \Rightarrow x = 3$

The sum of the first two and nine times the third is -79:

$$\frac{x}{a} + x + 9ax = -79 \Rightarrow \frac{3}{a} + 3 + 27a = -79$$

$$27a^2 + 82a + 3 = 0 \Rightarrow a = -3 \text{ or } a = -\frac{1}{27}$$

The numbers are: -1, 3, -9 or -81, 3, $-\frac{1}{9}$.

Application Activity 2.9

1. Find x such that 2, x , 18 are in geometric progression.
2. Is the sequence -2, 4, -8, 16, 32, 64 a geometric progression? Why?
3. Determine the common ratio of the sequence $\{3(-2)^n\}$

4. For what values of k , the numbers $1+k, \frac{5}{6}+k, \frac{13}{18}+k$ are in geometric progression.?
5. If $a^2+b^2, ab+bc$ and b^2+c^2 are in geometric progression, show that a, b, c are also in geometric progression.
6. If $\frac{1}{x+y}, \frac{1}{2y}, \frac{1}{y+z}$ are in arithmetic progression, show that x, y, z are in geometric progression.

2.3.2. General term of a geometric sequence

Activity 2.10



If $\{u_n\}$ is a geometric sequence with common ratio r and initial term u_1 , then

$$u_2 = u_1 r$$

$$u_3 = u_2 r = u_1 r r = u_1 r^2$$

$$u_4 = u_3 r = u_1 r^2 r = u_1 r^3$$

Continue in this manner up to u_{10} and conclude that the general formula should be used for u_n

From Activity 2.10, the n^{th} term, u_n , of a geometric sequence $\{u_n\}$ with common ratio r and initial term u_1 is given by $u_n = u_1 r^{n-1}$

Generally,

If u_n is the p^{th} term of the sequence, then the n^{th} term is given by $u_n = u_p r^{n-p}$

Example 2.32

If the first and tenth terms of a geometric sequence are 1 and 4, respectively, find the nineteenth term.

Solution

$$u_1 = 1 \text{ and } u_{10} = 4$$

$$\text{But } u_n = u_1 r^{n-1}, \text{ then } 4 = 1r^9 \Leftrightarrow r = \sqrt[9]{4} \text{ or } r = 4^{\frac{1}{9}}$$

Now,

$$\begin{aligned} u_{19} &= u_1 r^{19-1} \\ &= 1 \left(4^{\frac{1}{9}} \right)^{18} \\ &= 16 \end{aligned}$$

Thus, the nineteenth term of the sequence is 16.

Example 2.33

If the 2nd term and the 9th term of a geometric sequence are 2 and $-\frac{1}{64}$ respectively, find the common ratio.

Solution

$$u_2 = 2, \quad u_9 = -\frac{1}{64}$$

Using the general formula: $u_n = u_p r^{n-p}$

$$u_2 = u_9 r^{2-9}$$

$$2 = -\frac{1}{64} r^{-7}$$

$$\Leftrightarrow 128 = -\frac{1}{r^7}$$

$$\Leftrightarrow r^7 = -\frac{1}{128}$$

$$\Leftrightarrow r = \sqrt[7]{-\frac{1}{128}} \Rightarrow r = -\frac{1}{2}$$

The common ratio is $r = -\frac{1}{2}$.

Example 2.34

Find the number of terms in sequence 2, 4, 8, 16, ..., 256.

Solution

This sequence is geometric with common ratio 2, $u_1 = 2$ and $u_n = 256$

But $u_n = u_1 r^{n-1}$, then $256 = 2 \times 2^{n-1} \Leftrightarrow 256 = 2^n$ or $2^8 = 2^n \Rightarrow n = 8$.

Thus, the number of terms in the given sequence is 8.

Application Activity 2.10

1. If the second and fifth terms of a geometric sequence are 6 and -48 respectively, find the sixteenth term.
2. If the third term and the 8th term of a geometric sequence are $\frac{1}{2}$ and $\frac{1}{128}$ respectively, find the common ratio.
3. The 4th term of a geometric sequence is square of its 2nd term, and the first term is -3. Determine its 7th term.
4. Find the fourth term from the end of geometric sequence $8, 4, 2, \dots, \frac{1}{128}$
5. The fifth term of a geometric sequence is $\frac{81}{32}$ and the ratio of 3rd and 4th is $\frac{2}{3}$, write the geometric sequence and its 8th term.
6. If p^{th} terms of two sequences $5, 10, 20, \dots$ and $1280, 640, 320, \dots$ are equal, find the value of p .

2.3.3. Geometric means

Activity 2.11



Suppose that you need to form a geometric sequence of 6 terms such that the first term is 1 and the sixth term is 243. Write down that sequence.

If three or more than three numbers are in Geometric sequence, then all terms lying between the first and the last numbers are called Geometric means of the two numbers.

If B is geometric mean between A and C, then $B = \sqrt{AC}$ or $B^2 = AC$

To insert k terms called **geometric means** between two terms u_1 and u_n is to form a geometric sequence of $n = k + 2$ terms whose first term is u_1 and the last term is u_n .

While there are several methods, we will use our n^{th} term formula $u_n = u_1 r^{n-1}$.

As u_1 and u_n are known, we need to find the common ratio r taking $n = k + 2$ where k is the number of terms to be inserted.

Example 2.35

Insert three geometric means between 3 and 48.

Solution

Here $k = 3$, then $n = 5$, $u_1 = 3$ and $u_n = u_5 = 48$

$$u_5 = u_1 r^{n-1} \Leftrightarrow 48 = 3r^4 \Rightarrow r = 2$$

Inserting three terms using common ratio $r = 2$ gives 3, 6, 12, 24, 48

Example 2.36

Insert 6 geometric means between 1 and $-\frac{1}{128}$.

Solution

Here $k = 6$, then $n = 8$, $u_1 = 1$ and $u_n = u_8 = -\frac{1}{128}$

$$\Leftrightarrow -\frac{1}{128} = 1r^7 \Leftrightarrow r^7 = -\frac{1}{128}$$

$$\Leftrightarrow r^7 = -\frac{1}{(2)^7} \quad \Leftrightarrow r = \left[-\frac{1}{(2)^7} \right]^{\frac{1}{7}} = -\frac{1}{2}$$

Inserting 6 terms using common ratio $r = -\frac{1}{2}$ gives

$$1, -\frac{1}{2}, \frac{1}{4}, -\frac{1}{8}, \frac{1}{16}, -\frac{1}{32}, \frac{1}{64}, -\frac{1}{128}$$

Application Activity 2.11

1. Insert 5 geometric means between $\frac{1}{4}$ and $\frac{1}{256}$.
2. Insert 5 geometric means between 2 and $\frac{2}{729}$.

3. Find the geometric mean between
 - a) 2 and 98
 - b) $\frac{3}{2}$ and $\frac{27}{2}$
4. Suppose that 4,36,324 are in geometric progression. Insert two more numbers in this sequence so that it again forms a geometric sequence.
5. The arithmetic mean of two numbers is 34 and their geometric mean is 16. Find the numbers.

2.3.4. Geometric series

Activity 2.12



1. Consider a geometric sequence with initial term u_1 and common ratio r .

$$\text{Let } s_n = u_1 + u_2 + u_3 + \dots + u_n$$

$$s_n = u_1 + u_1 r + u_1 r^2 + \dots + u_1 r^{n-1} \quad (1)$$

- ⊙ Multiply both sides of (1) by r to obtain relation (2)
- ⊙ Subtract (2) from (1)
- ⊙ Give the general formula for S_n

2. Suppose that we need the product of $u_1, u_2, u_3, \dots, u_n$.

$$\text{Then } P_n = u_1 \times u_2 \times u_3 \times \dots \times u_n \quad \text{or} \quad P_n = u_1 \times u_1 r \times u_1 r^2 \times \dots \times u_1 r^{n-1}$$

Develop this relation and find P_n in terms of u_1, r and n . You will need the sum $S_{n-1} = 1 + 2 + \dots + n - 1$ which is

$$S_{n-1} = \frac{n-1}{2}(1+n-1) = \frac{n(n-1)}{2}$$

For finite geometric sequence $\{u_n\} = u_1, u_2, u_3, \dots, u_n$, the sum $\sum_{r=1}^n u_r = u_1 + u_2 + u_3 + \dots + u_n$ is called **geometric series**.

We denote the sum of the first n terms of the sequence by S_n .

$$\text{Thus, } S_n = u_1 + u_2 + u_3 + \dots + u_n = \sum_{r=1}^n u_r$$

From Activity 2.12, the sum of the first n terms of a geometric sequence with initial term u_1 and common ratio r is given by:

$$S_n = \frac{u_1(1-r^n)}{1-r} \quad \text{with } r \neq 1$$

If the initial term is u_0 , then the formula is $s_n = \frac{u_0(1-r^{n+1})}{1-r}$ with $r \neq 1$

If $r=1$, $s_n = nu_1$

Also, the product of the first n terms of a geometric sequence with initial term u_1 and common ratio r is given by $P_n = (u_1)^n r^{\frac{n(n-1)}{2}}$

If the initial term is u_0 then $P_n = (u_0)^{n+1} r^{\frac{n(n+1)}{2}}$

Example 2.37

Find the sum of the first 20 terms of a geometric sequence if the first term is 1 and common ratio is 2.

Solution

Here, $u_1 = 1, r = 2, n = 20$

Then,

$$s_{20} = \frac{1(1-2^{20})}{1-2} = \frac{1-2^{20}}{-1} = 1048575$$

Example 2.38

Let $u_{n+1} = u_n + \frac{1}{2^n}$, $u_0 = 0$ and $v_n = u_{n+1} - u_n$

Verify if v_n is a geometric sequence

Solution

v_n is a geometric sequence if and only if $\frac{v_n}{v_{n-1}}$ is a constant.

$$\begin{aligned} \text{Now, } \frac{v_n}{v_{n-1}} &= \frac{u_{n+1} - u_n}{u_n - u_{n-1}} = \frac{u_n + \frac{1}{2^n} - u_n}{u_{n-1} + \frac{1}{2^{n-1}} - u_{n-1}} \\ &= \frac{\frac{1}{2^n}}{\frac{1}{2^{n-1}}} = \frac{1}{2} \text{ which is a constant.} \end{aligned}$$

Thus $\{v_n\}$ is a geometric sequence.

The first term is $v_0 = 1$ and the common ratio is $r = \frac{1}{2}$

b) The general term is $v_n = v_0 r^n = \frac{1}{2^n}$.

Example 2.39

Find the product of the first 20 terms of a geometric sequence if the first term is 1 and common ratio is 2.

Solution

$$P_n = (u_1)^n r^{\frac{n(n-1)}{2}}$$

Here, $u_1 = 1, r = 2, n = 20$, Then, $P_{20} = (1)^{20} 2^{\frac{20(19)}{2}} = 2^{190}$

Application Activity 2.12

1. Find the sum of the first 8 terms of the geometric sequence 32, -16, 8, ...
2. Find the sum of the geometric sequence with the first term 0.99 and the common ratio is equal to the first term.
3. Find the first term and the common ratio of the geometric sequence for which $S_n = \frac{5^n - 4^n}{4^{n-1}}$
4. Find the product of the first 10 terms of the sequence in question 1.

2.3.5. Infinity geometric series**Activity 2.13**

Consider the infinite geometric series $\sum_{n=1}^{\infty} u_1 r^{n-1}$ where the sum of the first n terms is $S_n = \frac{u_1(1-r^n)}{1-r}$ ($r \neq 1$). Evaluate $\lim_{n \rightarrow +\infty} \frac{u_1(1-r^n)}{1-r}$ for $-1 < r < 1$.

From Activity 2.13, the sum to infinity of a geometric series with first term u_1 and the common ratio r is $S_{\infty} = \frac{u_1}{1-r}$ provided $-1 < r < 1$

Example 2.40

Given the geometric progression 16, 12, 9, Find the sum of terms up to infinity.

Solution

Here, $u_1 = 16, r = \frac{12}{16} = \frac{3}{4}$

Thus, $-1 < r < 1$ and hence the sum to infinity will exist

$$S_{\infty} = \frac{u_1}{1-r} = \frac{16}{1-\frac{3}{4}} = 64$$

The sum to infinity is 64.

Example 2.41

Express the recurring decimal $0.\overline{32}$ as a rational number.

Solution

$0.\overline{32} = \frac{32}{10^2} + \frac{32}{10^4} + \frac{32}{10^6} + \dots$ which is an infinite geometric series with the first term $u_1 = 0.32$ and common ratio is $r = 0.01$.

Since $-1 < r < 1$, the sum to infinity exist and equal to

$$\frac{u_1}{1-r} = \frac{0.32}{1-0.01} = \frac{0.32}{0.99} = \frac{32}{99}$$

Therefore, $0.\overline{32} = \frac{32}{99}$

Application Activity 2.13

1. Consider the infinite geometric series $\sum_{n=1}^{\infty} 10 \left(1 - \frac{3x}{2}\right)^n$.

a) For what values of x does a sum to infinity exist?

b) Find the sum of the series if $x = 1.3$

2. A ball is dropped from a height of 10 m and after each bounce, returns to a height which is 84% of the previous height. Calculate the total distance travelled by the ball before coming to rest.

2.4. Applications**Activity 2.14**

Discuss how sequences are used in real life problems.

There are many applications of sequences. Sequences are useful in our daily lives as well as in higher mathematics. For example, the interest portion of monthly payments made to pay off an automobile or home loan, and the list of maximum daily temperatures in one area for a month are sequences. Sequences are used in calculating interest, population growth, half-life and decay in radioactivity.

Example 2.42

A child building a tower with blocks uses 15 for the bottom row. Each row has 2 fewer blocks than the previous row. Suppose that there are 8 rows in the tower.

- How many blocks are used for the top row?
- What is the total number of blocks in the tower?

Solution

- The number of blocks in each row forms an arithmetic sequence with $u_1 = 15$ and $d = -2$
 $n = 8, u_8 = u_1 + (8-1)(-2)$. There is just one block in the top row.

- Here we must find the sum of the terms of the arithmetic sequence formed with $u_1 = 15, n = 8, u_8 = 1$

$$S_8 = \frac{8}{2}(15+1) = 64$$

There are 64 blocks in the tower.

Example 2.43

An insect population is growing in such a way that each new generation is 1.5 times as large as the previous generation. Suppose there are 100 insects in the first generation.

- How many will there be in the fifth generation?
- What will be the total number of insects in the five generations?

Solution

- The population can be written as a geometric sequence with $u_1 = 100$ as the first-generation population and common ratio $r = 1.5$. Then the fifth generation population will be

$u_5 = 100(1.5)^{5-1} = 506.25$. In the fifth generation, the population will number about 506 insects.

- b) The sum of the first five terms using the formula for the sum of the first n terms of a geometric sequence:

$$S_5 = \frac{100(1 - (1.5)^5)}{1 - 1.5} = 1318.75$$

The total population for the five generations will be about 1319 insects.



Notice

Another important application of sequences is their use in compound interest and simple interest.

The compound interest formula: The total amount accumulated A is given by:

$$A = P \left(1 + \frac{r}{k} \right)^{kt} \text{ with } P = \text{principle, } t = \text{time in years,}$$

$r =$ annual rate, and $k =$ number of periods per year.

The simple interest formula:

$$I = Prt \text{ with } I = \text{total interest, } P = \text{principle,}$$

$r =$ annual rate, and $t =$ time in years.

Example 2.44

If Linda deposits \$1300 in a bank at 7% interest compounded annually, how much will be in the bank 17 years later?

Solution

$$P = 1300, r = 7\% = 0.07, k = 1$$

$$A = 1300 \left(1 + \frac{0.07}{1} \right)^{1 \times 17} = 4106.46$$

The account will contain \$4,106.46.

Example 2.45

Find the accumulated value of \$15,000 at 5% per year for 18 years using simple interest.

Solution

$$P = 15000, r = 0.05, t = 18$$

$$I = 15000(0.05)(18)$$

$$= 13500$$

A total of \$13,500 in interest will be earned.

Hence, the accumulated value in the account will be $13,500 + 15,000 = \$28,500$.

Example 2.46

A mine worker discovers an ore sample containing 500 mg of radioactive material. It is discovered that the radioactive material has a half life of 1 day. Find the amount of radioactive material in the sample at the beginning of the 7th day.

Solution

Half life of one day means that half of the amount remains after 1 day.

Beginning of day 1: 500 mg	Beginning of day 2: 250 mg	Beginning of day 3: 125 mg	...
End of day 1: 250 mg	End of day 2: 125 mg	End of day 3: 62.5 mg	...

Decide to either work with the “beginning” of each day, or the “end” of each day, as each can yield the answer. Only the starting value and number of terms will differ. We will use “beginning”:

$$u_n = u_1 r^{n-1}$$

$$u_8 = 500 \left(\frac{1}{2} \right)^{7-1} = 7.8125 \text{ mg}$$

Unit Summary

1. Numbers in sequence are denoted $u_1, u_2, u_3, \dots, u_{n-1}, u_n, \dots$ and shortly $\{u_n\}$.

The natural number n is called **term number** and value u_n is called a **general term** of a sequence and the term u_1 is the **initial term**.

2. As a sequence continues indefinitely, it can be denoted as $\{u_n\}_{n=1}^{+\infty}$.

3. A sequence $\{u_n\}$ is said to be

- ⊙ increasing if $u_1 < u_2 < u_3 < \dots < u_n < \dots$
- ⊙ non-decreasing if $u_1 \leq u_2 \leq u_3 \leq \dots \leq u_n \leq \dots$
- ⊙ decreasing if $u_1 > u_2 > u_3 > \dots > u_n > \dots$
- ⊙ non-increasing $u_1 \geq u_2 \geq u_3 \geq \dots \geq u_n \geq \dots$

4. A numerical sequence is said to be **convergent** if the limit of its general term exists as n increases whereas if the limit does not exist (or is infinity) the sequence is said to be **divergent**. A number L is called **a limit of a numerical sequence** $\{u_n\}$ if $\lim_{n \rightarrow \infty} u_n = L$

5. One of the most famous and important of all diverging series is the **harmonic series**, $\sum_{k=1}^{+\infty} \frac{1}{k} = 1 + \frac{1}{2} + \frac{1}{3} + \frac{1}{4} + \dots$

6. Sequences of numbers that follow a pattern of adding a fixed number from one term to the next are called **arithmetic sequences** or **arithmetic progressions**.

7. For an arithmetic sequence, u_{n-1}, u_n, u_{n+1} , we have $2u_n = u_{n-1} + u_{n+1}$.

8. If u_p is any p^{th} term of a sequence then the n^{th} term is given by $u_n = u_p + (n - p)d$

9. The sum of the first n terms of a finite arithmetic sequence, with initial term u_1 is given by

$$s_n = \frac{n}{2}[u_1 + u_n]$$

10. Sequences of numbers that follow a pattern of multiplying a fixed number from one term to the next are called **geometric sequences** or **geometric progression**.
11. For a geometric sequence u_{n-1}, u_n, u_{n+1} , we have

$$u_n^2 = u_{n-1} \cdot u_{n+1}$$
12. The n^{th} term, u_n , of a geometric sequence $\{u_n\}$ with common ratio r and initial term u_1 is given by $u_n = u_1 r^{n-1}$
13. The sum of first n terms of a geometric sequence with initial term u_1 and common ratio r is given by:

$$s_n = \frac{u_1(1-r^n)}{1-r} \text{ with } r \neq 1.$$
14. Also, the product of first n terms of a geometric sequence with initial term u_1 and common ratio r is given by $P_n = (u_1)^n r^{\frac{n(n-1)}{2}}$.
15. For the formula $s_n = \frac{u_1(1-r^n)}{1-r}$
 If $-1 < r < 1$, $S_\infty = \frac{u_1}{1-r}$
16. Sequences are used in calculating interest, population growth, half-life and decay in radioactivity.

End of Unit Assessment

- Find the first four terms of the sequence
 - $\left\{ \frac{1-n}{n^2} \right\}$
 - $\left\{ \frac{(-1)^{n+1}}{2n-1} \right\}$
 - $\left\{ 2+(-1)^n \right\}$
- Find the formula for the n^{th} term of the sequence
 - 1, -1, 1, -1, 1, ...
 - 0, 3, 8, 15, 24, ...
 - 1, 5, 9, 13, 17, ...
- Which of the following sequences converge, and which ones diverge? Find the limit of each convergent sequence.
 - $\left\{ \sqrt{\frac{2n}{n+1}} \right\}$
 - $\frac{n}{2^n}$
 - $8^{\frac{1}{n}}$
- Find the 20th term of the following arithmetic progressions and calculate the sum of first 20 terms
 - 2, 6, 10, 14, ...
 - 5, -3.5, -2, -0.5, ...
- Find the n^{th} term of the following arithmetic progression and calculate the sum of first n terms
 - 4, 6, 8, 10, ...
 - 17, 14, 11, 8, ...
 - $1, \frac{n-1}{n}, \frac{n-2}{n}, \frac{n-3}{n}, \dots$
- In an arithmetic progression, we have:
 - $u_1 = 4, d = 2, n = 8$; find u_n and sum of terms
 - $d = 4, u_n = 39, n = 10$; u_1 and sum of terms
 - $u_1 = 3, u_n = 21, S_n = 120$; find n and d
 - $u_n = 199, n = 100, S_n = 10000$; find u_1 and d .
- Form an arithmetic progression such that the 4th term and 12th term are 40 and 42 respectively.
- In an arithmetic progression, the sum of the 8th and 14th terms is 50. The 5th term is equal to 13. Find that progression.

9. Insert 8 arithmetic means between -2 and $\frac{1}{4}$.
10. Find x consecutive integer numbers known that the first number is 8 and their sum is x^3 .
11. The sum of 3 consecutive terms in arithmetic progression is 33 and their product is 1287. What are those numbers?
12. Find the n^{th} term of the harmonic sequence whose first two terms are 6 and 3 respectively.
13. Insert three harmonic means between -2 and $\frac{2}{11}$.
14. The third and sixth terms of harmonic sequence are $\frac{5}{16}$ and $\frac{1}{5}$. Find the 10^{th} term.
15. In a geometric progression, we have
 - a) $u_1 = 3, r = 4, n = 5$; find u_n and sum of terms.
 - b) $u_n = \frac{3}{64}, u_1 = 12, n = 9$; find r and sum of terms.
16. If $\frac{1}{b-a}, \frac{1}{2b}, \frac{1}{b-c}$ form an arithmetic progression, show that a, b, c form a geometric progression.
17. In a geometric progression, the first and the third terms are 8 and 18 respectively. Find the 5^{th} term.
18. In a geometric progression, the first term is 32 and the product of the 3^{rd} and the 6^{th} terms is 17496. Find the 8^{th} term.
19. Insert 3 geometric terms between 2 and 8.
20. The sum of 3 numbers forming a geometric progression is 21 and the sum of their squares is 189. Find those numbers.
21. In a geometric progression with 5 terms, the common ratio is equal to $\frac{1}{4}$ of the first term, and the sum of the first two terms is 24. Find the 5^{th} term.

22. Calculate the numbers x, y, z known that x, y, z form an arithmetic progression, y, x, z form a geometric progression and the product xyz is equal to 216.
23. The sum of three numbers that form arithmetic progression is 51, and the difference between the squares of the greatest and the least is 408. Find the numbers.
24. The sum of four numbers that form an arithmetic progression is 38, and the sum of their squares is 406. Find the numbers.
25. The sum of five numbers that form an arithmetic progression is 10, and the product of the first, third and fifth is -64. Find the numbers.
26. The fourth, seventh and sixteenth terms of an arithmetic progression are in geometric progression. If the first six terms of the arithmetic progression have a sum of 12, find the common difference, of the arithmetic progression and the common ratio of the geometric progression.
27. The third, fifth and seventeenth terms of an arithmetic progression are in geometric progression. Find the common ratio of the geometric progression.
28. A mathematical child negotiates a new pocket money deal with her unsuspecting father in which she receives 1 pound on the first day of the month, 2 pounds on the second day, 4 pounds on the third day, 8 pounds on the fourth day, 16 pounds on the fifth day, ... until the end of the month. How much would the child receive during the course of a month of 30 days? (Give your answer to the nearest million pounds).
29. Find the common ratio of a geometric progression that has a first term of 5 and sum to infinity of 15.
30. The sum of the first two terms of a geometric progression is 9 and the sum to infinity is 25. If the common ratio is positive, find the common ratio and the first term.

31. A culture of bacteria doubles every 2 hours. If there are 500 bacteria at the beginning, how many bacteria will there be after 24 hours?
32. You complain that the hot tub in your hotel suite is not hot enough. The hotel tells you that they will increase the temperature by 10% each hour. If the current temperature of the hot tub is 75° F, what will be the temperature of the hot tub after 3 hours, to the nearest tenth of a degree?
33. The sum of the interior angles of a triangle is 180° , of a quadrilateral is 360° and of a pentagon is 540° . Assuming this pattern continues, find the sum of the interior angles of a dodecagon (12 sides).
34. The harmonic means of two numbers is 4. Their arithmetic mean A and geometric mean G satisfy the relation $2A + G^2 = 27$. Find the numbers.
35. Find the product of harmonic, arithmetic and geometric means of a and b .
36. If three positive numbers are in arithmetic, harmonic and geometric progression, then find their values.

Unit 3

Logarithmic and Exponential Equations

Introductory activity

An economist created a business which helped him to make money in an interesting way so that the money he/she earns each day doubles what he/she earned the previous day. If he/she had 200USD on the first day and by taking t as the number of days, discuss the money he/she can have at the t^{th} day through answering the following questions:

- Draw the table showing the money this economist will have on each day starting from the first to the 10th day.
- Plot these data in rectangular coordinates
- Based on the results in a), establish the formula for the economist to find out the money he/she can earn on the n^{th} day. Therefore, if t is the time in days, express the money $F(t)$ for the economist.
- Now the economist wants to possess the money F under the same conditions, discuss how he/she can know the number of days necessary to get such money from the beginning of the business.

Objectives

By the end of this unit, a student will be able to:

- Solve exponential equations.
- Solve logarithmic equations.
- Apply exponential and logarithmic equations in real life problems.

Exponential and logarithmic equations are really relevant in our day to day activities. The above events show us the areas where this unit finds use in our daily activities.

3.1. Exponential and logarithmic functions



Activity 3.1

Draw the graph of

$$y = 2^x \text{ for } -2 \leq x \leq 3$$

In the same plane, sketch the graph of $y = 2$ and $y = -3$. How many times do the horizontal line cross the curve of $y = 2^x$? How can you conclude?

Reflect $y = 2^x$ on the line $y = x$ and name the new curve $g(x)$

Remember that only a one to one function is invertible.

To find the inverse of the function $y = a^x$, where a is a positive real number different from 1, we make x the subject of the formula by introducing a new function called **logarithm** and write $x = \log_a y$ which is read “ x is **logarithm of y in base a** ”.

The graph of a logarithmic function is found by reflecting the graph of the corresponding exponential function in the line $y = x$. Thus, From Activity 3.1, the curve of $y = 2^x$ and $g(x)$ are inverse to each other. Thus, $g(x) = \log_2 x$.

Since $g(x) = \log_2 x$ is the inverse of $y = 2^x$, the curve of $g(x) = \log_2 x$ is the image of the curve of $y = 2^x$ with respect to the **first bisector**, $y = x$. Then the coordinates of the points for $y = 2^x$ are reversed to obtain the coordinates of the points for $g(x) = \log_2 x$.

Note that the words **power**, **index**, **exponent** and **logarithm** are synonymous; they are four different words to describe exactly the same thing.

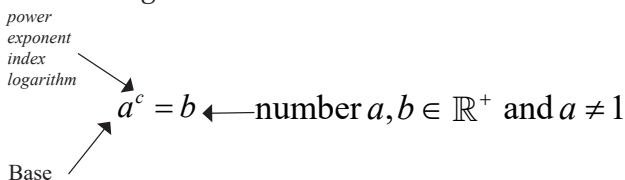

Example 3.1

In the same Cartesian plane, sketch the curve of the function $f(x) = 3^x$ for $-2 \leq x \leq 2$ and its inverse $f^{-1}(x)$ with the first bisector.

Solution

Table of coordinates of $f(x) = 3^x$

x	-2	-1.6	-1.2	-0.8	-0.4	0	0.4	0.8	1.2	1.6	2
y	0.1	0.2	0.3	0.4	0.6	1.0	1.6	2.4	3.7	5.8	9.0

Table of coordinates of $f^{-1}(x)$

x	0.1	0.2	0.3	0.4	0.6	1.0	1.6	2.4	3.7	5.8	9.0
y	-2	-1.6	-1.2	-0.8	-0.4	0	0.4	0.8	1.2	1.6	2

Curve

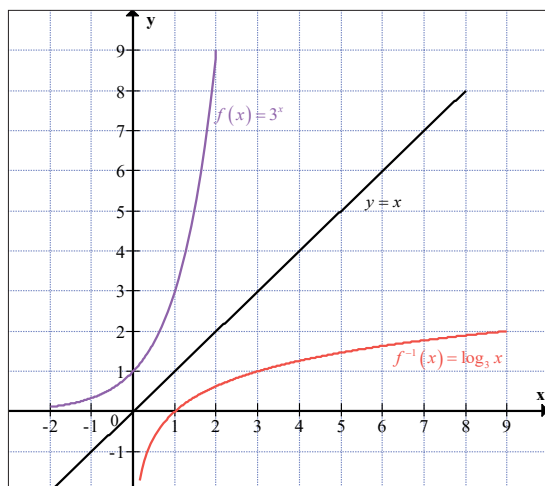

Application Activity 3.1

Sketch the following functions in Cartesian plane with their inverses

1. $y = \left(\frac{1}{2}\right)^x$, $-3 \leq x \leq 3$

2. $y = \left(\frac{1}{3}\right)^x$, $-2 \leq x \leq 2$

3.2. Exponential and logarithmic equations

Each exponential expression has a corresponding logarithmic expression.

The relationship is $b = a^c \Leftrightarrow c = \log_a b$. Thus, we may write $b = a^{\log_a b}$.

For example $100 = 10^2 \Leftrightarrow 100 = 10^{\log_{10} 100} \Rightarrow \log_{10} 100 = 2$

$$81 = 3^4 \Leftrightarrow 81 = 3^{\log_3 81} \Rightarrow \log_3 81 = 4$$

There are two common bases for logarithms, 10 and e . e is irrational number and $e \approx 2.718281828$, which we will prove in senior 6 that

it can be expressed as $e = \lim_{x \rightarrow \infty} \left(1 + \frac{1}{x}\right)^x$

You should find an "ln" button on your calculator which will evaluate logarithms to base e and "log" button to evaluate logarithms to base 10.



Activity 3.2

Let $p = \log_a x$ and $q = \log_a y$, where $a > 0$ and $a \neq 1$. Remember that these two statements can be written as $x = a^p$ and $y = a^q$. From product rule of exponent, express $\log_a xy$ in terms of $\log_a x$ and $\log_a y$.

HINT: $b = m^c \Leftrightarrow \log_m b = c$

Hence or otherwise, prove that $\log_a \left(\frac{x}{y}\right) = \log_a x - \log_a y$

Basic rules for exponents

For $a > 0$ and $a \neq 1, m, n \in \mathbb{R}$

- 1) $a^m \times a^n = a^{m+n}$
- 2) $a^m : a^n = a^{m-n}$
- 3) $\left(a^m\right)^n = a^{mn}$
- 4) $a^{-n} = \frac{1}{a^n}$
- 5) $a^n = \sqrt[n]{a}$
- 6) $a^n = \sqrt[n]{a^m}$
- 7) $a^{\log_a b} = b$

Basic rules for logarithms

$\forall x, y \in]0, +\infty[, a \in]0, +\infty[\setminus \{1\}$:

- a) $\log_a xy = \log_a x + \log_a y$
- b) $\log_a \frac{1}{y} = -\log_a y$

$$\text{c) } \log_a \frac{x}{y} = \log_a x - \log_a y \quad \text{d) } \log_a x^r = r \log_a x$$

Example 3.2

Write $2^6 = 64$ in logarithmic form.

Solution

$$2^6 = 64 \Leftrightarrow 2^6 = 2^{\log_2 64} \Rightarrow \log_2 64 = 6$$

Example 3.3

Write $\log_m b = c$ in exponential form.

Solution

$$\log_m b = c \Rightarrow b = m^c$$

Example 3.4

Find x if $\log_2 32 = x$

Solution

$$\log_2 32 = x \Rightarrow 32 = 2^x$$

But $32 = 2^5$.

$$\text{So } 32 = 2^x \Leftrightarrow 2^5 = 2^x \Rightarrow x = 5$$

Example 3.5

Find the numerical value of $\log_3 \sqrt[3]{9}$

Solution

Let $y = \log_3 \sqrt[3]{9}$, then $3^y = \sqrt[3]{9}$

$$\Leftrightarrow 3^y = 9^{\frac{1}{3}} \Leftrightarrow 3^y = 3^{2\left(\frac{1}{3}\right)} \Leftrightarrow 3^y = 3^{\frac{2}{3}} \Rightarrow y = \frac{2}{3}$$

Hence, $\log_3 \sqrt[3]{9} = \frac{2}{3}$

Application Activity 3.2

1. Prove basic rules for exponents

$$\text{a) } a^m \times a^n = a^{m+n} \quad \text{b) } a^m : a^n = a^{m-n} \quad \text{c) } (a^m)^n = a^{mn}$$

$$\text{d) } a^{-n} = \frac{1}{a^n} \quad \text{e) } a^{\frac{1}{n}} = \sqrt[n]{a} \quad \text{f) } a^{\frac{m}{n}} = \sqrt[n]{a^m}$$

2. Write each of the following in logarithmic form

$$\text{a) } 4^3 = 64 \quad \text{b) } 2^{-3} = \frac{1}{8} \quad \text{c) } \left(\frac{1}{2}\right)^x = y$$

$$\text{d) } p^3 = q \quad \text{e) } 8^x = 0.5 \quad \text{f) } 5^{-p} = q$$

3. Find the exact value of x , showing your working

$$\text{a) } \log_2 8 = x \quad \text{b) } \log_x 125 = 3 \quad \text{c) } \log_x 64 = 0.5$$

$$\text{d) } \log_4 64 = x \quad \text{e) } \log_9 x = 3\frac{1}{2} \quad \text{f) } \log_2 \left(\frac{1}{2}\right) = x$$

4. Find the numerical value of each of the following

$$\text{a) } \log_3 243 \quad \text{b) } \log_5 \sqrt{125} \quad \text{c) } \log_5 0.008$$

$$\text{d) } \log_5 \left(\frac{1}{125}\right) \quad \text{e) } \log_{64} 4 \quad \text{f) } \log_3 3$$

$$\text{g) } \log_a a \quad \text{h) } \log_a 1$$



Activity 3.3

Prove each of the following logarithmic laws

1. $\log_a (m^p) = p \log_a m$ **The Power Law**

2. $\log_a b = \frac{\log_c b}{\log_c a}$ **The Change of Base Law**

The change of base rule is very useful since all logarithmic calculations are performed either in base 10 or in base e .

⊙ $\log_{10} x$ is usually written $\log x$ which is called decimal (or common) logarithm.

⊙ $\log x$: the power to which 10 must be raised to produce x .

⊙ $\log_e x$ is usually written $\ln x$ which is called natural logarithm. Thus, $\ln x$: the power to which e must be raised to produce x
Generally, $\log_a x$: the power to which a must be raised to produce x .

Example 3.6

Calculate to 3 significant figures, the value of $\log_2 10$.

Solution

$$\log_2 10 = \frac{\log 10}{\log 2} = \frac{1}{0.30103} = 3.322(3 s.f.)$$

Or

$$\log_2 10 = \frac{\ln 10}{\ln 2} = \frac{2.302585}{0.693147} = 3.322(3 s.f.)$$

Example 3.7

If $y = 2x^3$, find a linear expression connecting $\log x$ and $\log y$.

Solution

Introducing \log on both sides of $y = 2x^3$ yields

$$\begin{aligned} \log y &= \log 2x^3 \Leftrightarrow \log y = \log 2 + \log x^3 \\ &\Leftrightarrow \log y = \log 2 + 3 \log x \end{aligned}$$

Example 3.8

Express $\log_a \frac{x^3}{y^2 z}$ in terms of $\log_a x$, $\log_a y$ and $\log_a z$

Solution

$$\begin{aligned} \log_a \frac{x^3}{y^2 z} &= \log_a x^3 - \log_a y^2 z \\ \Leftrightarrow \log_a \frac{x^3}{y^2 z} &= 3 \log_a x - (\log_a y^2 + \log_a z) \\ \Leftrightarrow \log_a \frac{x^3}{y^2 z} &= 3 \log_a x - 2 \log_a y - \log_a z \end{aligned}$$

Example 3.9

Write an expression equivalent to $\log y = 3 - 2 \log x$ without using logarithms.

Solution

$$\log y = 3 - 2 \log x$$

$$\Leftrightarrow \log y = \log 1000 - \log x^2$$

$$\Leftrightarrow \log y = \log \frac{1000}{x^2}$$

$$\Rightarrow y = \frac{1000}{x^2}$$

$$\text{Or } \log y = 3 - 2 \log x$$

$$\Rightarrow y = 10^{3-2\log x} \text{ as } \log_a b = c \Leftrightarrow b = a^c$$

$$\Leftrightarrow y = 10^{3-\log x^2}$$

$$\Leftrightarrow y = \frac{10^3}{10^{\log x^2}}$$

$$\Rightarrow y = \frac{1000}{x^2} \quad \text{since } b = a^{\log_a b}$$

Example 3.10

Solve the equation $2^{3x} = 3^{2x-1}$

Solution

$2^{3x} = 3^{2x-1}$ taking logarithms of both sides and applying logarithmic laws give

$$3x \log 2 = (2x - 1) \log 3 \Leftrightarrow 3x \log 2 = 2x \log 3 - \log 3$$

$$\Leftrightarrow 3x \log 2 - 2x \log 3 = -\log 3$$

$$\Leftrightarrow x(3 \log 2 - 2 \log 3) = -\log 3$$

$$\Leftrightarrow x = -\frac{\log 3}{3 \log 2 - 2 \log 3}$$

$$\Rightarrow x = 9.327$$

Example 3.11

Solve the equation $2(5^{2x}) - 5^x = 6$

Solution

Let $y = 5^x$, with $y > 0$.

Then $2y^2 - y = 6$

$$\text{Or } 2y^2 - y - 6 = 0$$

$$(2y+3)(y-2) = 0$$

$\Rightarrow y = -1\frac{1}{2}$ is to be excluded since $y = 5^x$ must be positive

$$\text{or } y = 2$$

$$\text{So } y = 2 \text{ gives } 5^x = 2 \Rightarrow x = \log_5 2 = \frac{\log 2}{\log 5} = 0.431$$

Application Activity 3.3

1. Given that $\log_m x = p$, express each of the following in terms of p

a) $\log_m(x^4)$ b) $\log_m\left(\frac{1}{x^2}\right)$ c) $\log_m(mx)$

2. Find the general solution of the following equation

$$9^{\cos x} - 2 \times 3^{\cos x} + 1 = 0$$

3. Solve for the following equations for x and/or y

a) $\ln(x^2 - 1) = \ln(4x - 1) - 2 \ln 2$ b) $2 \log_2 x + \log_x 2 = 3$

c) $\begin{cases} 2 \ln x + 3 \ln y = -2 \\ 3 \ln x + 5 \ln y = -4 \end{cases}$ d) $\begin{cases} \ln(xy) = 7 \\ \ln \frac{x}{y} = 1 \end{cases}$

e) $9^x - 2 \times 3^{x+1} = 27$

3.3. Applications

Exponential growth



Activity 3.4

In a laboratory, for experiment we start with 2 cells in a dish. The number of cells in the dish doubles every 30 minutes.

- How many cells are in the dish after four hours?
- After what time are there 2^{13} cells in the dish?
- After $10\frac{1}{2}$ hours there are 2^{22} cells in the dish and an experiment fluid is added which eliminates half of the cells. How many cells are left?

A population whose rate of increase is proportional to the size of the population at any time obeys a law of the form $P = Ae^{kt}$. This is known as **exponential growth**.

Example 3.12

According to United Nation data, the world population at the beginning of 1975 was approximately 4 billion and growing at rate of about 2% per year. Assuming an exponential growth model, estimate the world population at the beginning of the year 2020.

Solution

Let t be time (in years) elapsed from the beginning of 1975 and $P(t)$ be world population in billions.

Since the beginning of 1975 corresponds to $t = 0$, it follows from the given data that $P_0 = P(0) = 4$ (billions).

Since the growth rate is 2% ($k = 0.02$), it follows that the world population at time t will be $P(t) = P_0 e^{kt} = 4e^{0.02t}$.

Since the beginning of the year 2020 corresponds to $t = 45$ (2020-1975=45), it follows that the world population by the year 2020 will be $P(45) = 4e^{0.02(45)}$ (billion)

$$\begin{aligned} \text{Or } P(45) &= 4e^{0.9} \text{ (billion)} \\ &= 4(2.459603) \text{ (billion)} \\ &= 9.838412 \text{ (billion)} \end{aligned}$$

Which is a population of approximately 9.8 billion.

Exponential decay

Activity 3.5



The amount, $A(t)$ gram, of radioactive material in a sample after t years is given by $A(t) = 80 \left(2^{-\frac{t}{100}} \right)$.

- Find the amount of material in the original sample.
- Calculate the half-life of the material (the half-life is the time taken for half of the original material to decay).
- Calculate the time taken for the material to decay 1 gram.

A population whose rate of decrease is proportional to the size of the population at any time obeys a law of the forms $P = Ae^{-kt}$. The negative sign on exponent indicates that the population is decreasing. This is known as **exponential decay**.

If a quantity has an exponential growth model, then the time required for it to double in size is called the **doubling time**. Similarly, if a quantity has an exponential decay model, then the time required for it to reduce in value by half is called the **halving time**. For radioactive elements, halving time is called **half-life**.

Doubling time



Activity 3.6

Show that the doubling time (T) for a quantity with an exponential growth model ($k > 0$) depends only on the growth rate not on the amount present initially and is $T = \frac{1}{k} \ln 2$.

Doubling and halving times depend only on the growth rate and not on the amount present initially.

Doubling time for a quantity with an exponential growth model ($k > 0$) is $T = \frac{1}{k} \ln 2$ and halving time for a quantity with an exponential decay model ($k < 0$) is $T = -\frac{1}{k} \ln 2$.

Example 3.13

The radioactive element carbon-14 has a half-life of 5,750 years. If 100 grams of this element are present initially, how much will be left after 1,000 years?

Solution

As $T = -\frac{1}{k} \ln 2$, the decay constant is

$$k = -\frac{1}{T} \ln 2$$

$$\begin{aligned}
 &= -\frac{1}{5750} \ln 2 \\
 &= -\frac{1}{5750} 0.693147181 \\
 &= -0.000120547 \\
 &\approx -0.00012
 \end{aligned}$$

Radioactive decay obeys a law of the forms $P(t) = P_0 e^{-kt}$.

Thus, if we take $t = 0$ to be the present time, then $P_0 = P(0) = 100$, thus, the amount of carbon-14 after 1,000 years will be

$$\begin{aligned}
 P(1,000) &= 100e^{-0.00012(1,000)} \\
 &= 100e^{-0.12} \\
 &\approx 100(0.88692) \\
 &\approx 88.692
 \end{aligned}$$

Thus, about 88.692 grams of carbon-14 will remain.

Example 3.14

Magnitudes of **earthquakes** are measured using the **Richter scale**. On this scale, the magnitude R of an earthquake is given by $R = \log\left(\frac{I}{I_0}\right)$ where I_0 is a fixed standard intensity used for comparison, and I is the intensity of earthquakes being measured.

- Show that if an earthquake measures $R = 3$ on Richter scale, then its intensity is 1000 times the standard, that is, $I = 1,000I_0$.
- The San Francisco earthquake of 1906 registered $R = 8.2$ on Richter scale. Express its intensity in terms of the standard intensity.
- How many times more intense is an earthquake measuring $R = 8$ than one measuring $R = 4$?

Solution

- If an earthquake measures $R = 3$ on Richter scale, then $\log\left(\frac{I}{I_0}\right) = 3 \Rightarrow \frac{I}{I_0} = 10^3$

$$\Leftrightarrow I = 10^3 I_0$$

$$I = 1000 I_0$$

Therefore, intensity is 1,000 times the standard, that is, $I = 1,000 I_0$.

b) The San Francisco earthquake of 1906 registered

$$R = 8.2 \text{ on Richter scale. It means that } \log\left(\frac{I}{I_0}\right) = 8.2 \text{ or}$$

$$\frac{I}{I_0} = 10^{8.2} \Leftrightarrow I = 10^{8.2} I_0 \text{ which expresses intensity in}$$

terms of the standard intensity.

c) Let E_1, E_2 be earthquakes measuring $R = 8$ and $R = 4$ respectively.

$$\text{For } E_1 : R = 8 \Rightarrow \frac{I}{I_0} = 10^8 \Leftrightarrow I = 10^8 I_0;$$

$$\text{For } E_2 : R = 4 \Rightarrow \frac{I}{I_0} = 10^4 \Leftrightarrow I = 10^4 I_0;$$

$$\text{Intensity of } E_1 \text{ is } I_1 = 10^8 I_0 \quad (1)$$

$$\text{Intensity of } E_2 \text{ is } I_2 = 10^4 I_0 \quad (2)$$

The ratio of two above equations yields

$$\frac{I_1}{I_2} = \frac{10^8 I_0}{10^4 I_0} = 10^4 \Rightarrow I_1 = 10^4 I_2 \Leftrightarrow I_1 = 10,000 I_2$$

An earthquake measuring $R = 8$ is 10000 times more intense than one measuring $R = 4$.

Example 3.15

Jack operates an account with a certain bank which pays a compound interest rate of 13.5% per annum. He opened the account at the beginning of the year with 500,000 Frw and deposits the same amount of money at the beginning of every year. Calculate how much he will receive at the end of 9 years. After how long will the money have accumulated to Frw 3.32 million?

Solution

The compound interest formula:

The 1st deposit will be

$$500,000 + \frac{500,000 \times 13.5}{100} = 500,000 \left(1 + \frac{13.5}{100}\right)$$

$$\text{Or } 500,000 + \frac{500,000 \times 13.5}{100} = 500,000 \times 1.135$$

The 2nd deposit will grow to $500,000 \times (1.135)^2$

The 3rd deposit will grow to $500,000 \times (1.135)^3$

The nth deposit will grow to $500,000 \times (1.135)^n$

So the 9th deposit will grow to $500,000 \times (1.135)^9$

The total sum

$$\begin{aligned} & 500,000 \times (1.135) + 500,000 \times (1.135)^2 + 500,000 \times (1.135)^3 + \dots + 500,000 \times (1.135)^9 \\ & = 500,000 \left[1.135 + (1.135)^2 + (1.135)^3 + \dots + (1.135)^9 \right] \end{aligned}$$

From $S_n = u_1 \left(\frac{1-r^n}{1-r} \right)$, we get

$$\begin{aligned} S_9 &= 500,000 \left[1.135 \left(\frac{1-(1.135)^9}{1-1.135} \right) \right] \\ \text{or } S_9 &= \frac{-500,000 \times 1.135 \times 2.125811278}{-0.135} \end{aligned}$$

$$\text{or } S_9 = 8,936,281$$

Finding how long it will take the money to accumulate to 3,320,000

Frw

$$S_n = 3,320,000$$

$$\Rightarrow 500,000 \left[1.135 \left(\frac{1-(1.135)^n}{1-1.135} \right) \right] = 3,320,000$$

$$\Rightarrow \frac{1-(1.135)^n}{1-1.135} = \frac{3,320,000}{500,000 \times 1.135}$$

$$\Leftrightarrow \frac{1-(1.135)^n}{-0.135} = \frac{3,320,000}{500,000 \times 1.135}$$

$$\Leftrightarrow 1-(1.135)^n = -\frac{332 \times 0.135}{50 \times 1.135}$$

$$\Leftrightarrow (1.135)^n - 1 = \frac{332 \times 0.135}{50 \times 1.135}$$

$$\Leftrightarrow (1.135)^n - 1 = 0.7897$$

$$(1.135)^n = 0.7897 + 1$$

$$(1.135)^n = 1.7897$$

Introducing logarithm to the base 10 on both sides gives

$$n \log(1.135) = \log(1.7897)$$

$$n = \frac{\log(1.7897)}{\log(1.135)}$$

$$n \approx 4.6$$

Hence, it will take 4.6 years for the amount to accumulate to 3.32 million Frw.

Example 3.16

A man deposits 800,000 Frw into his savings account on which interest is 15% per annum. If he makes no withdrawals, after how many years will his balance exceed 8 million Frw?

Solution

Here, the interest rate will be compound such that amount is

$P\left(1 + \frac{r}{100}\right)^n$, where n = period of time.

$$8,000,000 = 800,000 \left(1 + \frac{15}{100}\right)^n$$

$$10 = (1 + 0.15)^n$$

$$10 = (1.15)^n$$

$$\log 10 = \log (1.15)^n$$

$$1 = n \log (1.15)$$

$$n = \frac{1}{\log (1.15)}$$

$$n \approx 16.5 \text{ years}$$

Application Activity 3.4

1. Sugar dissolves in water at a rate proportional to the amount still undissolved. If there were 50 kg of sugar present initially, and at the end of 5 h only 20 kg are left, how much longer it will it take until 90% of the sugar is dissolved?
2. Find the half-life of a radioactive substance if after 1 year 99.57% of an initial amount still remains.
3. Scientists who do carbon-14 dating use a figure of 5,700 years for its half-life. Find the age of a sample in which 10% of the radioactive nuclei originally present have decayed?
4. If the half-life of radium is 1,690 years, what percentage of the amount present now will be remaining after
 - a) 100 years
 - b) 1,000 years?
5. In the first few weeks after birth, a baby gains weight at a rate proportional to its weight. A baby weighing 4kg at birth weighs 4.4 kg after 2 weeks. How much did the baby weigh 5 days after birth?
6. How much money needs to be invested today at a nominal rate of 4% compounded continuously, in order that it should grow to in 7 days?
7. If the purchasing power of the dollard is decreasing at an effective rate of 9% annually, how long will it take for the purchasing power to be reduced to 25 cents?
8. Suppose that the bacteria in a colony can grow unchecked, by the law of exponential change. The colony starts with 1 bacterium and doubles every half hour. How many bacteria will the colony contain at the end of 24 hours?
9. The number of people cured is proportional to the number that is infected with the disease.
 - a) Suppose that in the course of any given year the number of cases of disease is reduced by 20 %. If there are 10,000 cases today, how many years will it take to reduce the number to 1,000?
 - b) Suppose that in any given year the number of cases can be reduced by 25% instead of 20% .
 - (i) How long will it take to reduce the number of cases to 1,000?
 - (ii) How long will it take to eradicate the disease, that is, to reduce the number of cases to less than 1?

Unit Summary

1. To find the inverse of the function $y = a^x$, we write $x = \log_a y$
2. The graph of a logarithmic function is found by reflecting the graph of the corresponding exponential function in the line $y = x$.
3. Each exponential expression has a corresponding logarithmic expression. The relationship is $b = a^c \Leftrightarrow c = \log_a b$. Thus, we may write $b = a^{\log_a b}$.

4. Basic rules for exponents

For $a > 0$ and $a \neq 1$, $m, n \in \mathbb{R}$

$$\text{a) } a^m \times a^n = a^{m+n}$$

$$\text{b) } a^m : a^n = a^{m-n}$$

$$\text{c) } (a^m)^n = a^{mn}$$

$$\text{d) } a^{-n} = \frac{1}{a^n}$$

$$\text{e) } a^{\frac{1}{n}} = \sqrt[n]{a}$$

$$\text{f) } a^{\frac{m}{n}} = \sqrt[n]{a^m}$$

$$\text{g) } a^{\log_a b} = b$$

5. Basic rules for logarithms

$\forall x, y \in]0, +\infty[$, $a \in]0, +\infty[\setminus \{1\}$:

$$\text{a) } \log_a xy = \log_a x + \log_a y$$

$$\text{b) } \log_a \frac{1}{y} = -\log_a y$$

$$\text{c) } \log_a \frac{x}{y} = \log_a x - \log_a y$$

$$\text{d) } \log_a x^r = r \log_a x$$

$$\text{e) } \log_a b = \frac{\log_c b}{\log_c a}$$

6. Exponential and logarithmic functions are used in population growth, half life, and decay in radioactivity. Logarithmic functions are also used to find interest rate problems.

A quantity is said to have an **exponential growth (decay) model** if at each instant of time its rate of increase (decrease) is proportional to the amount of the quantity present.

Exponential growth is given by $P(t) = P_0 e^{kt}$

Exponential decay is given by $P(t) = P_0 e^{-kt}$

For exponential growth model, the time required for it to double in size is called the **doubling time**. Similarly, for exponential decay model, the time required for it to reduce in value by half is called the **halving time**. For radioactive elements, halving time is called **half-life**.

End of Unit Assessment

1. Solve for x

- | | |
|--|---------------------------------|
| a) $\log_3 x = 4$ | b) $\ln(x-2)(x-1) = \ln(2x+8)$ |
| c) $\begin{cases} x^2 + y^2 = 130 \\ \ln x + \ln y = \ln 63 \end{cases}$ | d) $\log_x 5 = \log_5 x$ |
| e) $2^{x-1} - 2^{x-3} = 2^{3-x} - 2^{1-x}$ | f) $e^{4x} - 13e^{2x} + 36 = 0$ |

2. Find the numerical value

- | | | |
|------------------------|-------------------|----------------|
| a) $\log_2 32$ | b) $\log_4 8$ | c) $\log_6 7$ |
| d) $\log_5 \sqrt{125}$ | e) $\log_5 0.008$ | f) $\log_9 10$ |

3. A bank pays compound interest on money invested in an account. After n years, a sum of \$2,000 will rise to $\$2,000 \times 1.08^n$.

- How much money is in the account after three years?
- After how many years will the original \$2,000 have nearly doubled?

4. Kamali's bike is ill. Its computer controlled ignition system has a virus. The doctor has advised Kamali to keep the bike warm, in which case the number of germs in the bike will decay exponentially and will be $1,000,000 \times 2^{-n}$ after n hours.

- How many germs will be there after 10 hours?
- The bike will be cured when it contains less than one germ. After how many hours will it be cured?

5. The speed $V(t)$, of a certain chemical reaction at $t^\circ\text{C}$ is given by $V(t) = V(0) \times 5^{\frac{t}{30}}$. At what temperature will the speed of reaction be twice that at 0°C ?

6. The population of a country grows according to the law $P = Ae^{0.06t}$ where P million is the population at time t years and A is a constant. Given that at time $t = 0$, the population is 27.3 million, calculate the population when
- a) $t = 10$ b) $t = 15$ c) $t = 25$
7. The population of a country grows according to the law $P = 12e^{kt}$ where P million is the population at time t years and k is a constant. Given that when $t = 7, P = 15$, find the time for which the population will be
- a) 20 million b) 30 million c) 35 million
8. The population of a city $P(n)$, n years after the population was P is given by $P(n) = p \left(e^{\frac{1}{30}} \right)^n$. Find:
- a) The time taken for the population to double.
b) The time taken for the population to reach 1 million from an original population of 10,000.
9. The rate of increase of a population P million at time t years is proportional to the population at that time. Given that at time $t = 0, P = 36.4$ and that at time $t = 10, P = 41.2$. Find the law for the size of the population in the form $P = f(t)$.
10. The town of Grayrock had a population of 10,000 in 1960 and 12,000 in 1970.
- a) Assuming an exponential growth model, estimate the population in 1980.
b) What is the doubling time for the town's population?
11. The law of cooling for a bath of water is $\theta = Ae^{-0.05t}$ where θ is excess of temperature of the water over the temperature of the bathroom at time t minutes and A is a constant. Given that at time $t = 0$ the temperature of the water is 60°C and that the bathroom has a constant temperature of 15°C , calculate the value of t when the temperature of the water is
- a) 50°C b) 35°C c) 27°C

12. The law of cooling is $\theta = Ae^{-0.02t}$ where $\theta^\circ C$ is the excess of temperature of the water over the temperature of the room temperature at time t minutes and A is a constant. Given that the constant room temperature is $20^\circ C$, and that when $t=0$ the temperature of the water is $80^\circ C$, find the temperature of the water in Kelvin when

- a) $t=10$ b) $t=20$ c) $t=45$

13. At a time $t=0$, one bacteria is placed in a culture in a laboratory. The number of bacteria doubles every 10 minutes

Time t in minutes	0	10	20	30	40	...
Number of bacteria	1	2	4	8	16	...

- a) Draw a graph to show the growth of the bacteria from $t=0$ to $t=120$ minutes.
- b) Use a scale of 1 cm to 10 minutes across the page and 5 cm to 1,000 units up the page.
- c) Use your graph to estimate the time taken to reach 800 bacteria.
14. An economist estimates that the population of a country A will be multiplied by 1.2 every 10 years and that the population of a country B will be multiplied by 1.05 every 10 years. In 1980, the population of A and B were 36 million and 100 million respectively.
- a) Draw a graph to show the projected population of the two countries from 1980 to 2060.
- b) Use a scale of 2 cm to 10 years across the page and 2 cm to 20 million up the page.
- c) Estimate when the population of A will exceed the population of B for the first time.

Unit 4

Solving Equations by Numerical Methods

Introductory activity

We know how to solve linear equations and quadratic equations, either by factorising, by formula or by completing the square.

Solve the following equations:

1. $\theta^2 - \sin^2 \theta = 0$

2. $\theta - 1 - \sin \theta = 0$

Is it possible to solve the second equation? What are other methods you can use to solve it?

Did you understand talking about a method with approximation to the solution?

Objectives

By the end of this unit, a student will be able to solve equations by numerical methods:

- ⦿ Linear interpolation and extrapolation.
- ⦿ Location of roots: by graphical and analytical methods.
- ⦿ Iterative methods: newton raphson Method and general iterations.
- ⦿ Bisection method

4.1. Linear Interpolation and extrapolation

4.1.1. Linear interpolation



Activity 4.1

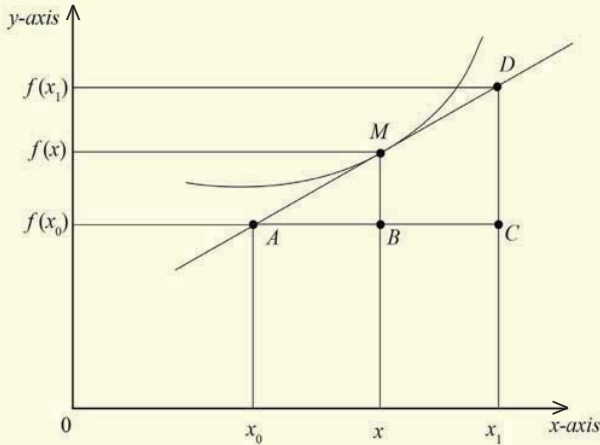

1. Identify the curve
2. Draw a straight line for the curve
3. Find the gradient of straight line from point
 - Ⓐ A, C and D
 - Ⓑ A, B and M
4. Equating expressions (slopes) from 3), make f the subject of formula.

Linear interpolation is a process whereby the non tabulated values of the function are estimated on the assumption that the function behaves sufficiently smooth between the tabular point.

$y = y_1 + \frac{(x - x_1)(y_2 - y_1)}{x_2 - x_1}$ **on Formula** is given as,

An example of a linear interpolation is given in the graph shown below. Here, the line segment AB is given. The point C is interpolated; while the point D is extrapolated by extending the straight line beyond AB .

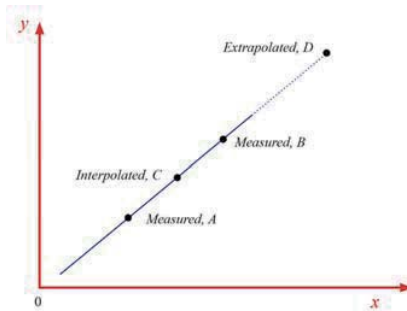

Example 4.1

From the following table, use interpolation to find $f(1.15)$

x	1	2	3
$f(x)$	2	8	1

Solution

x	1	1.15	2
$f(x)$	2	$f(1.15)$	8

$$\frac{\text{Change in } y}{\text{Change in } x} = \frac{8-2}{2-1} = \frac{f(1.15)-2}{1.15-1}$$

$$\text{Or } \frac{\text{change in } y}{\text{change in } x} = 6 = \frac{f(1.15)-2}{0.15}$$

$$\text{Or } 0.9 = f(1.15) - 2$$

$$\text{Hence, } f(1.15) = 2.9$$

Example 4.2

Use interpolation to find $\sin 0.857$

x in radians	0.85	0.86	0.87
$\sin x$	0.7513	0.7578	0.7643

Solution

$$x = 0.857$$

$$\frac{\text{Change in } y}{\text{Change in } x} = \frac{0.7578-0.7513}{0.86-0.85} = \frac{f(x)-0.7513}{x-0.85}$$

$$\frac{0.7578 - 0.75513}{0.86 - 0.85} = \frac{f(0.857) - 0.7513}{0.857 - 0.85}$$

$$\frac{0.0065}{0.01} = \frac{f(0.857) - 0.7513}{0.007}$$

$$0.65 \times 0.007 = f(0.857) - 0.7513$$

$$0.00455 = f(0.857) - 0.7513$$

$$f(0.857) = 0.00455 + 0.7513 = 0.75585$$

Hence, $\sin 0.857 = 0.75585$

Example 4.3

A curve $y = f(x)$ passes through the point $(4, 1.88)$ and $(5, 1.84)$. Find the value of $f(4.2)$.

Solution

$$\frac{f_2 - f_1}{x_2 - x_1} = \frac{f - f_1}{x - x_1}$$

x	4	4.2	5
$f(x)$	1.88	f	1.84

$$\frac{1.84 - 1.88}{5 - 4} = \frac{f - 1.88}{4.2 - 4}$$

$$f = 1.88 - 0.008 = 1.872$$

$$-0.04 \times 0.2 = f - 1.88$$

$$f(4.2) = 1.872$$

Application Activity 4.1

1. In experiment to measure the rate of cooling of an object, the following temperature $\theta^\circ\text{C}$ against time T in seconds, were recorded;

Temperature, $\theta^\circ\text{C}$	80	70.2	65.8	61.9	54.2
Time, T	0	10	15	20	30

Use linear interpolation to find the value of

- a) θ when $T=18\text{s}$ b) T when 60°C

2. The table shows the value of function at a set of points

x	0.9	1.0	1.1	1.2
$f(x)$	0.266	0.242	0.218	0.198

Use linear interpolation to find:

a) the value of $f(1.04)$

b) the value of x corresponding to $f(x)=0.25$

4.1.2. Linear extrapolation

Activity 4.2



The winning times for the women's 100 metre race are given in the following table. Estimate the winning time in the year 2010. Is this a good estimate?

Winner	Country	Year	Time (seconds)
Mary Lines	UK	1922	12.8
Leni Schmidt	Germany	1925	12.4
Gerturd Glasitsch	Germany	1927	12.1
Tollien Schuurman	Netherlands	1930	12
Helen Stephens	USA	1935	11.8
Lulu Mae Hymes	USA	1939	11.5
Fanny Blankers-Koen	Netherlands	1943	11.5
Marjorie Jackson	Australia	1952	11.4
Vera Krepkina	Soviet Union	1958	11.3
Wyomia Tyus	USA	1964	11.2
Barbara Ferrell	USA	1968	11.1
Ellen Strophal	East Germany	1972	11
Inge Helten	West Germany	1976	11
Marlies Gohr	East Germany	1982	10.9
Florence Griffith Joyner	USA	1988	10.5

Extrapolation involves approximating the value of a function for given values outside the given tabulated values.

We may also use the formula $y = y_1 + \frac{(x - x_1)(y_2 - y_1)}{x_2 - x_1}$

In the graph below, the three points x_1 , x_2 and x_3 are given and the value of point x_4 is extrapolated.

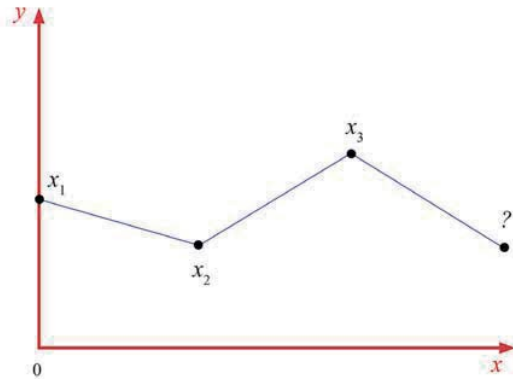

Example 4.4

From the following table, find $(3.363)^2$

x	x^2
3.35	11.2225
3.36	11.2896

Solution

$$\text{Using } \frac{f_2 - f_1}{x_2 - x_1} = \frac{f - f_1}{x - x_1} \text{ gives } \frac{11.2896 - 11.2225}{3.36 - 3.35} = \frac{f - 11.2225}{3.363 - 3.35}$$

$$\frac{0.0671}{0.01} = \frac{f - 11.2225}{0.013}$$

$$0.0671 = \frac{f - 11.2225}{13}$$

$$f - 11.2225 = 0.08723$$

$$f = 0.08723 + 11.2225 = 11.30973$$

$$(3.363)^2 = 11.30973$$

Application Activity 4.2

1. The two known points lying on a straight line are $(0, 7)$ and $(3, 10)$. Find the value of y at $x = 4.5$ on this straight line using linear extrapolation.
2. The end points of a straight line are given by $(0.3, 0.8)$ and $(1.8, 2.7)$. Extrapolate the value of y when $x = 2.3$.

4.2. Location of roots

4.2.1. Analytical method

Activity 4.3



Consider the equation $x^2 - 5x + 2 = 0$. Complete the following table;

x	0	1	2	3	4	5
$y = x^2 - 5x + 2$						

Squeeze each root of the equation $x^2 - 5x + 2 = 0$ between two consecutive integers.

The root of $f(x) = 0$ lies in interval $]a, b[$ if $f(a)f(b) < 0$; in other words, $f(a)$ and $f(b)$ are of opposite sign.

Example 4.5

Squeeze the real root of the equation $x^3 - x - 1 = 0$ between two consecutive integers.

Solution

Let $f(x) = x^3 - x - 1$

x	-3	-2	-1	0	1	2
$y = x^3 - x - 1$	-25	-7	-1	-1	-1	5

The root of $x^3 - x - 1 = 0$ lies in interval $]1, 2[$ since $f(1)f(2) < 0$.

Example 4.6

Show that the equation $x = \ln(8-x)$ has a root between 1 and 2.

Solution

$$f(x) = x - \ln(8-x)$$

$$f(1) = 1 - \ln(7) = -0.946$$

$$f(2) = 2 - \ln(6) = 0.208$$

Since $f(1) < 0$ while $f(2) > 0$, the equation $x = \ln(8-x)$ has a root between 1 and 2.

Application Activity 4.3

1. Show that the equation $x^3 - 3x - 12 = 0$ has a root between $x = 2$ and $x = 3$. Hence, use linear interpolation once to get the first approximation to the root.
2. Show that the equation $3x^2 + x - 5 = 0$ has a root between 1 and 2. Hence, use linear interpolation to calculate the root to 2 decimal places.

4.2.2. Graphical method**Activity 4.4**

Consider the equation $x^2 - 5x + 2 = 0$.

1. Construct the graph of $y = x^2 - 5x + 2$.
2. Locate the ranges of root of equation $x^2 - 5x + 2 = 0$.
3. Rearrange the equation so that you get the form $h(x) = g(x)$ where $h(x)$ and $g(x)$ are new functions.
4. Prepare two tables for $y = h(x)$ and $y = g(x)$ taking values of x between a and b .
5. Plot these points and join them to get smooth curves.

To solve the equation $f(x) = 0$, graphically, we draw the graph of $y = f(x)$ and read from it the value of x for which $f(x) = 0$, i.e.

the x -coordinates of the points where the curve $y = f(x)$ cuts the x -axis.

Alternatively, we would rearrange $f(x) = 0$, in the form $h(x) = g(x)$, and find the x -coordinates of the points where the curves $y = h(x)$ and $y = g(x)$ intersect.

Example 4.7

Copy and complete the following table for $y = x^3$ and $y = x + 1$.

x	-1.0	-0.5	0	0.5	1	1.5	2.0
$y = x^3$							
x	-1	0	1	2			
$y = x + 1$							

Using one pair of axes, draw the graphs of $y = x^3$ and $y = x + 1$, $-1 \leq x \leq 2$. Use your graphs to find an approximate solution to the equation $x^3 - x - 1 = 0$ in the range $-1 \leq x \leq 2$.

Solution

x	-1.0	-0.5	0	0.5	1	1.5	2.0
$y = x^3$	-1.0	-0.125	0	0.125	1	3.375	8.0

x	-1	0	1	2
$y = x + 1$	0	1	2	3

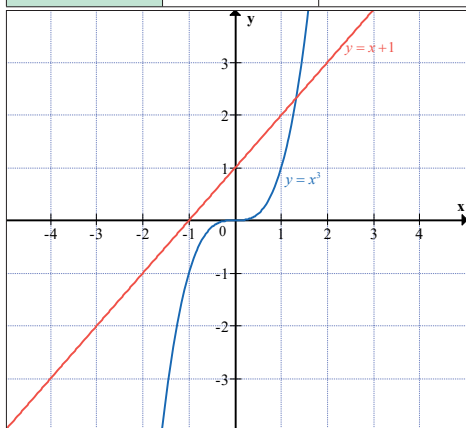

From the intersection of the graphs, an approximate solution to the equation $x^3 - x - 1 = 0$ in the range $-1 \leq x \leq 2$ is 1.3.

Example 4.8

Find graphically the positive root of the equation $x^3 - 6x - 13 = 0$

Solution

$$f(x) = x^3 - 6x - 13 = 0$$

$$f(1) = 1 - 6 - 13 = -18 < 0 \quad f(2) = 8 - 12 - 13 = -17 < 0$$

$$f(3) = 27 - 18 - 13 = -4 < 0 \quad f(4) = 64 - 24 - 13 = 27 > 0$$

The root of $f(x) = x^3 - 6x - 13 = 0$ lies between 3 and 4 as $f(3)$ and $f(4)$ are opposite in sign.

$$f(x) = x^3 - 6x - 13 = 0 \text{ can be rewritten as } x^3 = 6x + 13$$

$$y = x^3 \text{ and } y = 6x + 13.$$

Let us draw two curves for $y = x^3$ and $y = 6x + 13$.

x	3.0	3.2	3.4	3.6	3.8	4.0
$y = x^3$	27	32.8	39.3	46.7	54.9	64

x	3.0	3.2	3.4	3.6	3.8	4.0
$y = 6x + 13$	31	32.2	33.4	34.6	35.8	37

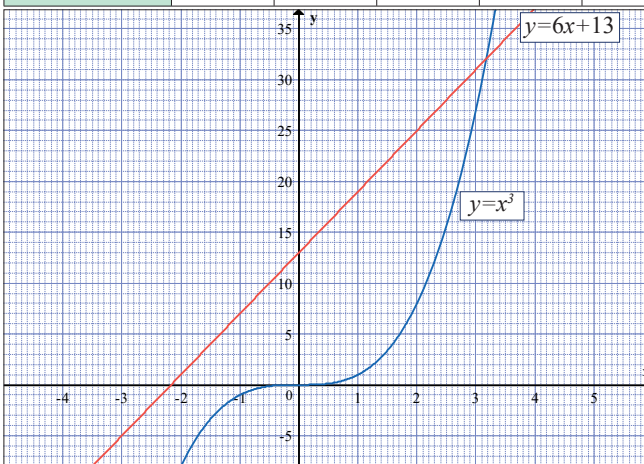

From the intersection of the graphs, an approximate solution to the equation $x^3 - 6x - 13 = 0$ in the range $3 \leq x \leq 4$ is 3.2.

Application Activity 4.4

1. Use graphical method to show that the equation $e^x - 2x - 1 = 0$ has two real roots.
2. Given the equation $\sin x - \frac{x}{2} = 0$, show by plotting suitable graphs on the same axes that the root lies between $\frac{\pi}{2}$ and $\frac{3\pi}{4}$.
3. Draw the graph of $y = x^3$ and $y = -2x + 20$ and find the approximate solution of the equation $x^3 + 2x - 20 = 0$
4. Solve graphically $x^3 - 2x - 5 = 0$
5. Solve graphically the equation $x - 1 = \sin x$

4.3. Iterative methods

4.3.1. Newton-Raphson method



Activity 4.5

Consider the graph of $y = f(x)$. Suppose that the exact solution is $x = X$ and that our initial, good approximate root is x_1 .

1. Draw the tangent at $(x_1, f(x_1))$; write that tangent equation.
2. Let $x_1 + h = x_2$ be a better approximate root, from tangent equation in 1), find the value of x_2 .

HINT: For this case, $y = 0$

By this method, we get closer approximation of the root of an equation if we already know its good approximate root.

Let the equation be $f(x) = 0$.

Let its good approximate root be x_1 and correct root be $x_1 + h$.

Now we proceed to find h as follows:

Since $x_1 + h$ is the correct root of $f(x) = 0$, thus $f(x_1 + h) = 0$.

We note that the point-slope form of the tangent line to $y = f(x)$ at the initial approximation x_1 is

$$y - f(x_1) = f'(x_1)(x - x_1) \quad (1)$$

If $f'(x_1) \neq 0$, then the line is not parallel to the x -axis and consequently it crosses the x -axis at some point $(x_1 + h, 0)$ or $(x_2, 0)$.

Substituting the coordinates of this point in (1) yields

$$-f(x_1) = f'(x_1)(x_2 - x_1)$$

Solving for x_2 , we obtain

$$-\frac{f(x_1)}{f'(x_1)} = x_2 - x_1$$

Or

$$x_2 = x_1 - \frac{f(x_1)}{f'(x_1)} \quad (2)$$

Similarly, we get the third approximate, taking $x_2 + h = x_3$,

that is,

$$x_3 = x_2 - \frac{f(x_2)}{f'(x_2)} \quad (3)$$

provided $f'(x_2) \neq 0$. In general, if x_n is the n th approximation, then it is evident from the pattern in (2) and (3) that the improved approximation x_{n+1} is given by:

$$x_{n+1} = x_n - \frac{f(x_n)}{f'(x_n)} \quad n = 1, 2, 3, \dots \quad (4)$$



Notice

In the beginning, we guess two numbers a and b such that $f(a)f(b) < 0$. Then the first approximate root x_1 lies between a and b .

⊙ If $f'(x_1) = 0$ or nearly zero, this method fails.

Example 4.9

Use the Newton-Raphson method to approximate the real solution of the equation $x^3 - x - 1 = 0$.

Solution

Let $f(x) = x^3 - x - 1$, $f'(x) = 3x^2 - 1$ and (4) or Newton-Raphson formula becomes

$$x_{n+1} = x_n - \frac{x_n^3 - x_n - 1}{3x_n^2 - 1}$$

Or after combining terms and simplifying

$$x_{n+1} = \frac{2x_n^3 + 1}{3x_n^2 - 1}.$$

$$f(1) = 1^3 - 1 - 1 = -1 < 0$$

$$f(2) = 2^3 - 2 - 1 = 5 > 0$$

Then the first approximate root x_1 lies between 1 and 2.

Let us use $x_1 = 1.5$ as our first approximation; letting $n = 1$ and substituting $x_1 = 1.5$ gives

$$x_2 = \frac{2(1.5)^3 + 1}{3(1.5)^2 - 1} = 1.34782609$$

Next, we let $n = 2$ and substitute $x_2 = 1.34782609$ to obtain

$$x_3 = \frac{2(1.34782609)^3 + 1}{3(1.34782609)^2 - 1} = 1.32520040$$

If we continue this process until two identical approximations are generated in succession, we obtain:

$$x_4 = 1.32471817$$

$$x_5 = 1.32471796$$

$$x_6 = 1.32471796$$

At this stage, there is no need to continue further. Thus, the solution is approximately $x \approx 1.32471796$

Example 4.10

Use the Newton-Raphson method to find the next approximate root of the equation $x^3 - 5x + 3 = 0$.

Solution

Let $f(x) = x^3 - 5x + 3$, $f'(x) = 3x^2 - 5$ and Newton-Raphson formula becomes

$$x_{n+1} = x_n - \frac{x_n^3 - 5x_n + 3}{3x_n^2 - 5}$$

Or after combining terms and simplifying

$$x_{n+1} = \frac{2x_n^3 - 3}{3x_n^2 - 5}.$$

$$f(0) = 3 > 0$$

$$f(1) = 1^3 - 5 + 3 = -1 < 0$$

Then, the first approximate root x_1 lies between 0 and 1.

Let us use $x_1 = 0.5$ as our first approximation; letting $n = 1$ and substituting $x_1 = 0.5$ gives

$$x_2 = \frac{2(0.5)^3 - 3}{3(0.5)^2 - 5} = 0.647059$$

Next, we let $n = 2$ and substitute $x_2 = 0.647059$ to obtain

$$x_3 = \frac{2(0.647059)^3 - 3}{3(0.647059)^2 - 5} = 0.656573$$

$$x_4 = \frac{2(0.656573)^3 - 3}{3(0.656573)^2 - 5} = 0.65662$$

$$x_5 = \frac{2(0.65662)^3 - 3}{3(0.65662)^2 - 5} = 0.65662$$

The solution is approximately $x \approx 0.65662$.

Example 4.11

Find the positive root of the equation $x - \cos x = 0$.

Solution

Let $f(x) = x - \cos x$, $f'(x) = 1 + \sin x$ and Newton-Raphson formula becomes

$$x_{n+1} = x_n - \frac{x_n - \cos x_n}{1 + \sin x_n}$$

Or after combining terms and simplifying

$$x_{n+1} = \frac{x_n \sin x_n + \cos x_n}{1 + \sin x_n}$$

$$f(0) = 0 - 1 = -1 < 0$$

$$f(1) = 1 - 0.540302 = 0.459698 > 0$$

Then the first approximate root x_1 lies between 0 and 1.

Let us use $x_1 = 0.5$ as our good approximation; letting $n = 1$ and substituting $x_1 = 0.5$ gives

$$x_2 = \frac{0.5 \sin 0.5 + \cos 0.5}{1 + \sin 0.5} = 0.755222417$$

Next, we let $n = 2$ and substitute $x_2 = 0.755222417$ to obtain

$$x_3 = \frac{0.755222417 \sin 0.755222417 + \cos 0.755222417}{1 + \sin 0.755222417} = 0.739141666$$

$$x_4 = \frac{0.739141666 \sin 0.739141666 + \cos 0.739141666}{1 + \sin 0.739141666} = 0.739085134$$

$$x_5 = \frac{0.739085134 \sin 0.739085134 + \cos 0.739085134}{1 + \sin 0.739085134} = 0.739085133$$

$$x_6 = \frac{0.739085133 \sin 0.739085133 + \cos 0.739085133}{1 + \sin 0.739085133} = 0.739085133$$

The solution is approximately $x \approx 0.739085133$.

Application Activity 4.5

Solve the following equations by Newton-Raphson method

- $x^3 - x = 2$ to three decimal places
- $x^3 - 3x + 3 = 0$ to three decimal places
- $e^x = 3 - x$ to five decimal places
- $x^5 + x^4 - 5 = 0$
- $2x^2 + 4x - 3 = 0; x > 0$
- Apply Newton-Raphson method to find an approximate solution of the equation $e^x - 3^x = 0$

Correct up to three significant figure, (assume $x = 0.4$ as an approximate root of the equation).

4.3.2. General iteration method

Activity 4.6



Consider the equation $x^3 - 3x - 5 = 0$.

Rearrange the equation so that you get the form $x = g(x)$ where $g(x)$ is a new function. By letting $x_{n+1} = g(x_n)$ find to 3 decimal places, a root of equation $x^3 - 3x - 5 = 0$, starting with $x_1 = 2$.

When trying to solve an equation $f(x) = 0$ by an iterative method, you first rearrange $f(x) = 0$ into a form $x = g(x)$. The iteration formula is then

$$x_{n+1} = g(x_n).$$

In activity 4.4, we rearranged the equation $x^2 - 5x + 2 = 0$ into the form $x = \pm\sqrt{5x - 2}$

$$\text{Or } x = \frac{x^2 + 2}{5} \text{ or } x = 5 - \frac{2}{x}, x \neq 0 \text{ or } x = -\frac{2}{x-5}, x \neq 5.$$

From these different rearrangements, we have one of the iteration formula and get better approximate root.

Example 4.12

Let us try $x_{n+1} = \sqrt{5x_n - 2}$, starting with $x_1 = 4$. Then

$$x_2 = \sqrt{5 \times 4 - 2} = \sqrt{18} = 4.242640687$$

$$x_3 = \sqrt{5 \times 4.242640687 - 2} = 4.38328683$$

$$x_4 = \sqrt{5 \times 4.38328683 - 2} = 4.462783229$$

$$x_5 = \sqrt{5 \times 4.462783229 - 2} = 4.507096199$$

$$x_6 = \sqrt{5 \times 4.507096199 - 2} = 4.531609095$$

$$x_7 = \sqrt{5 \times 4.531609095 - 2} = 4.545112262$$

$$x_8 = \sqrt{5 \times 4.545112262 - 2} = 4.552533505$$

$$x_9 = \sqrt{5 \times 4.552533505 - 2} = 4.556607019$$

$$x_{10} = \sqrt{5 \times 4.556607019 - 2} = 4.55884142$$

$$x_{11} = \sqrt{5 \times 4.55884142 - 2} = 4.560066568$$

$$x_{12} = \sqrt{5 \times 4.560066568 - 2} = 4.56073819$$

So, one root of $x^2 - 5x + 2 = 0$ is 4.56 (correct to 2 decimal places).

Now try

$$x_{n+1} = \frac{x_n^2 + 2}{5}, \text{ starting with } x_1 = 4. \text{ Then } x_2 = 3.6$$

$$x_3 = 2.992$$

$$x_4 = 2.1904128$$

$$x_5 = 1.359581647$$

$$x_6 = 0.76969245$$

$$x_7 = 0.518485293$$

$$x_8 = 0.4537654$$

$$x_9 = 0.441180607$$

$$x_{10} = 0.438928065$$

$$x_{11} = 0.438531569$$

This root is $x = 0.44$ (2 d.p.).

This iteration formula, starting at $x_1 = 4$, leads to other roots of the equation $x^2 - 5x + 2 = 0$.

Now try $x_{n+1} = 5 - \frac{2}{x_n}, x_n \neq 0$ and $x_{n+1} = -\frac{2}{x_n - 5}, x_n \neq 5$, starting at $x_1 = 4$

n	$x_{n+1} = 5 - \frac{2}{x_n}, x_n \neq 0$	$x_{n+1} = -\frac{2}{x_n - 5}, x_n \neq 5$
1	4.5	2
2	4.5555556	0.66666666
3	4.56097561	0.461538461
4	4.561497326	0.440677966
5	4.561547479	0.43866171
6		0.438467807
Best approximate root	4.56	0.44

This iteration formula $x_{n+1} = 5 - \frac{2}{x_n}, x_n \neq 0$ and $x_{n+1} = -\frac{2}{x_n - 5}, x_n \neq 5$ lead to roots 4.56, 0.44 respectively of the equation $x^2 - 5x + 2 = 0$ and you are back to the previous roots.

The bisection method

Let f be a real valued function of x such that: $f(x)$ is continuous on an interval $[a, b]$ and $f(a)f(b) < 0$

Then $f(x)$ changes sign on $[a, b]$ and has root on $[a, b]$.

Definition: The simplest numerical procedure for finding a root is to repeatedly halve the interval $[a, b]$, keeping the half for which $f(x)$ changes sign.

This procedure is called the bisection method, and is guaranteed to converge to a root

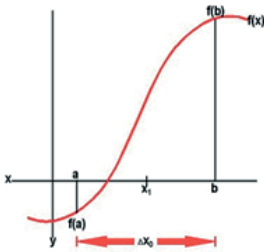

Given such a function and an error tolerance of $\varepsilon > 0$, (the absolute error in calculating the root must be less than ε); the bisection method consists of the following steps:

Step 1: Define $c = \frac{a+b}{2}$.

Step 2: If $b - c < \varepsilon$, then accept c as the root and stop.

Step 3: If $b - c \geq \varepsilon$ and $f(a)f(b) < 0$, then set c as the new b .

Otherwise, set c as the new a and return to step 1.

Example 4.13

Find a root of the equation $x^6 - x - 1 = 0$, accurate to within $\varepsilon = 0.001$, given that it has a root on $[1, 2]$.

Solution:

Let α be a root. That is $1 \leq \alpha \leq 2$.

If $f(x) = x^6 - x - 1$, then $f(1)f(2) = -1 < 0$.

So, given $a = 1$ and $b = 2$, then $c = \frac{1+2}{2} = 1.5$. $b - c = 0.5 > \varepsilon$.

Now the bisection algorithm is detailed in the following table.

n	a	b	c	$b - c$	$f(c)$
1	1	2	1.5	0.5	8.8906
2	1	1.5	1.25	0.25	1.5647
3	1	1.25	1.125	0.125	-0.0977
4	1.125	1.25	1.1875	0.0625	0.6167
5	1.125	1.1875	1.1562	0.0312	0.2333
6	1.125	1.1562	1.1406	0.0156	0.0616
7	1.125	1.1406	1.1328	0.0078	-0.0196
8	1.1328	1.1406	1.1367	0.0039	0.0206
9	1.1328	1.1367	1.1348	0.0020	0.004
10	1.1328	1.1348	1.1338	0.00098	-0.0096

Remark that after 10 steps (iterations) we have

$b - c = 0.00098 < 0.001 = \varepsilon$. Hence the required approximate root is $c = 1.1338$.

Note that the inequality $n \geq \frac{\log\left(\frac{b-a}{\varepsilon}\right)}{\log 2}$ can give us the number of iterations needed for a required accuracy ε .

Application Activity 4.6

1. Use the bisection method to solve the equation $e^x - x = 2$, with accuracy error of $\varepsilon = 0.001$.
 2. Solve the equation $x - 2 - \ln x = 0$, correct to 3 decimal places, using the bisection method.
1. a) Show that $x^2 - 3x + 1 = 0$ has one root lying between 0 and 1 and another lying between 2 and 3.
 - b) Show that $x^2 - 3x + 1 = 0$ can be rearranged into the form:
 - i) $x = \frac{x^2 + p}{q}$ where p and q are constants.
 - ii) $x = r + \frac{s}{x}$ where r and s are constants
 And state the values of p , q , r and s .
 - c) Using the iteration formula $x_{n+1} = \frac{x_n^2 + p}{q}$ together with your values of p and q , starting at $x_1 = 0.5$ find, to 3 decimal places, one root of $x^2 - 3x + 1 = 0$
 - d) Using the iteration formula $x_{n+1} = r + \frac{s}{x_n}$ together with your values of r and s find, to 3 decimal places, the second root of $x^2 - 3x + 1 = 0$

Unit Summary

1. Linear interpolation is a process whereby the non tabulated values of the function are estimated on the assumption that the function behaves sufficiently smooth between the tabular point. Extrapolation involves approximating the value of a function for given values outside the given tabulated values. The **linear interpolation** and **extrapolation** are found by using formula $y = y_1 + \frac{(x - x_1)(y_2 - y_1)}{x_2 - x_1}$
2. In order to find a root of equation $f(x) = 0$ by iteration, the equation must first be rearranged in the form $x = g(x)$.
The iteration formula is then $x_{n+1} = g(x_n)$
3. Each iteration formula with a given starting point can only lead to one root of the equation, utmost.

End of Unit Assessment

1. a) Show that $x^3 = 14$ has one root lying between 2 and 3, and can be rearranged into the form $x = \frac{p}{x^2} + \frac{x}{2}$ where p is a constant and state the value of p .
 b) Using the iteration formula $x_{n+1} = \frac{p}{x_n^2} + \frac{x_n}{2}$ together with your values of p , starting at $x_0 = 2.5$, find, to 3 significant figures, a root of $x^3 = 14$.
2. Approximate $\sqrt[3]{6}$ by applying the Newton-Raphson method to the equation $x^3 - 6 = 0$.
3. Solve the following equations by the Newton-Raphson method
 - a) $x^3 - x + 3 = 0$
 - b) $x^4 + x - 3 = 0; x < 0$
 - c) $x - 2 \sin x = 0$
 - d) $xe^x - 2 = 0$
4. Show graphically, or otherwise, that the equation $\ln x - 4 + x = 0$ has only one real root and prove that this root lies between 2.9 and 3.
 By taking 2.9 as first approximation to this root and applying the Newton-Raphson process once to the equation $\ln x - 4 + x = 0$, or otherwise, find a second approximation, giving your answer to 3 significant figures.
5. Solve graphically $x - 2 \sin x = 0$
6. Use the Newton-Raphson to solve
 - a) $\sin x = x - \frac{1}{2}$, $x_0 = 1$, to 4 dp
 - b) $x^4 - 22x - 50 = 0$, $x_0 = 3.5$ to 4 significant figures
7. Use the iteration formula to solve $x_{n+1} = 3^{\frac{1}{x_n}}$ with $x_0 = 1.5$ to find the value, to 3 significant figures, to which the sequence x_0, x_1, x_2, \dots tends. This sequence leads to one root of an equation. State the equation.

8. The equation $x^2 + 4x = 2$ has two roots, one near $x = 0$ and the other near $x = -4$

a) Using $x_{n+1} = \frac{2}{x_n + 4}$ with $x_0 = 0$ find the root near $x = 0$,
(correct to 2 decimal places).

b) Why could we not use the formula $x_{n+1} = \frac{2}{x_n + 4}$ with $x_0 = -4$?

c) Using $x_{n+1} = \frac{2}{x_n}$ with $x_0 = -4$, find the root near $x = -4$
(correct to 2 decimal places).

Unit 5

Trigonometric Functions and their Inverses

Introductory activity

- Given the function $y = f(x) = \cos x$,
 - Complete the table of values of $y = f(x)$ for $-2\pi \leq x \leq 2\pi$
 - Use the values obtained from a) to draw the graph for $y = f(x)$,
 - Find the values of x for which $f(x) = 0$. They are $f^{-1}(0)$.
- You studied trigonometry in previous levels, give two examples of applications of trigonometric functions in real life.

Objectives

By the end of this unit, a student will be able to:

- ⊙ Find the domain and range of trigonometric function, and their inverses.
- ⊙ Study the parity of trigonometric functions.
- ⊙ Study the periodicity of trigonometric functions.
- ⊙ Evaluate limits of trigonometric functions.
- ⊙ Differentiate trigonometric functions and their inverses.
- ⊙ Apply trigonometry in real life.

In this unit, we will see how we can use trigonometry to resolve problems we might encounter.

5.1. Generalities on trigonometric functions and their inverses

5.1.1. Domain and range of six trigonometric functions



Activity 5.1

State the values of x where the following functions are not defined:

1. $y = \sin x$ 2. $y = \cos x$ 3. $y = \tan x$

4. $y = \cot x$ 5. $y = \sec x$ 6. $y = \csc x$

Remember that $\tan x = \frac{\sin x}{\cos x}$, $\sec x = \frac{1}{\cos x}$, $\csc x = \frac{1}{\sin x}$ and

rational functions are not defined for all values where denominator is zero.

Cosine and sine

$\sin x$ and $\cos x$ are functions which are defined for all positive and negative values of x even for $x = 0$. Thus, the domain of $\sin x$ and $\cos x$ is the set of real numbers. The range of $\sin x$ and $\cos x$ is $[-1, 1]$.

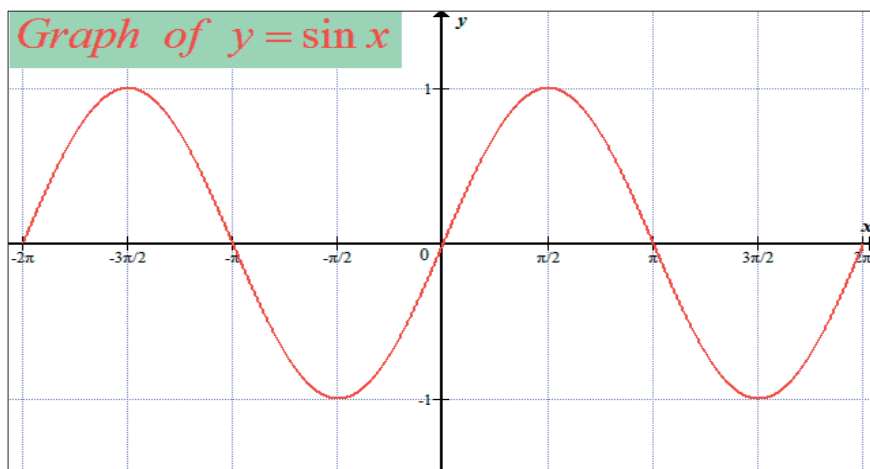

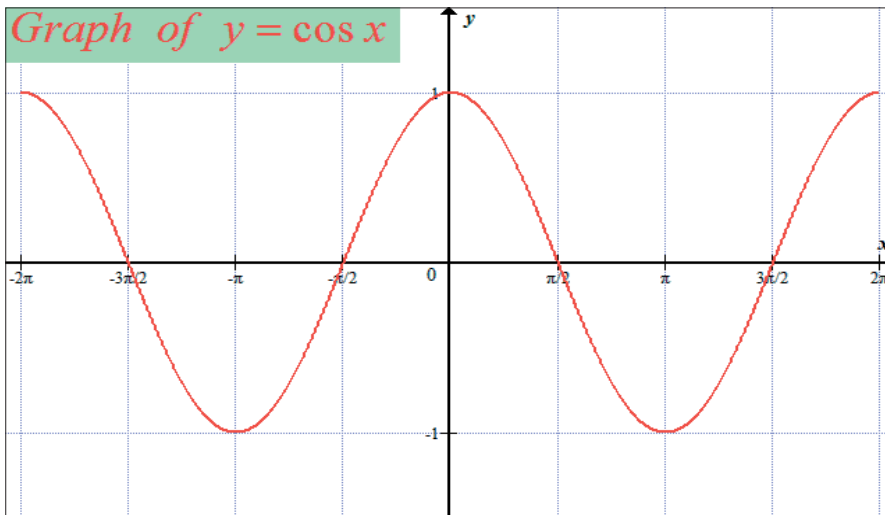

Tangent and cotangent

Function $\tan x$ is not defined for $x = \pm\frac{\pi}{2}, \pm\frac{3\pi}{2}, \dots$. Generally, $\tan x$ is not defined for $x = \frac{\pi}{2} + k\pi, k \in \mathbb{Z}$. Thus, domain of $\tan x$ is $\mathbb{R} \setminus \left\{ \frac{\pi}{2} + k\pi \right\}, k \in \mathbb{Z}$. The range of $\tan x$ is the set of real numbers.

Function $\cot x$ is not defined for $x = 0, \pm\pi, \pm2\pi, \dots$. Generally, $\cot x$ is not defined for $x = k\pi, k \in \mathbb{Z}$. Thus, domain of $\cot x$ is $\mathbb{R} \setminus \{k\pi\}, k \in \mathbb{Z}$. The range of $\cot x$ is the set of real numbers.

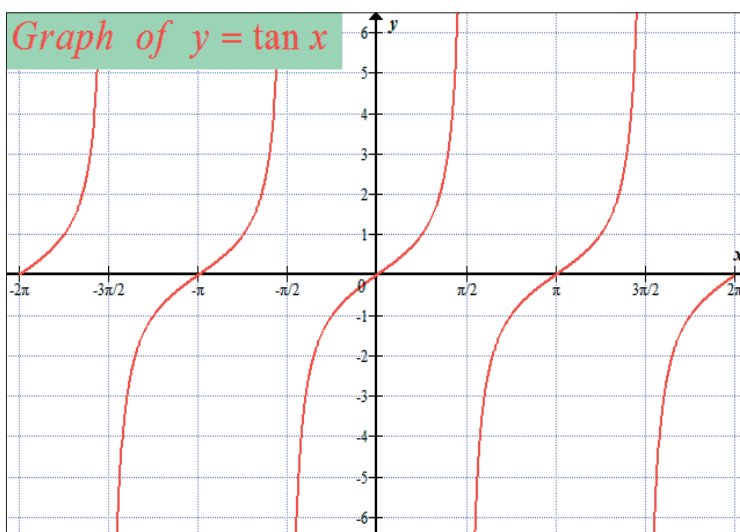

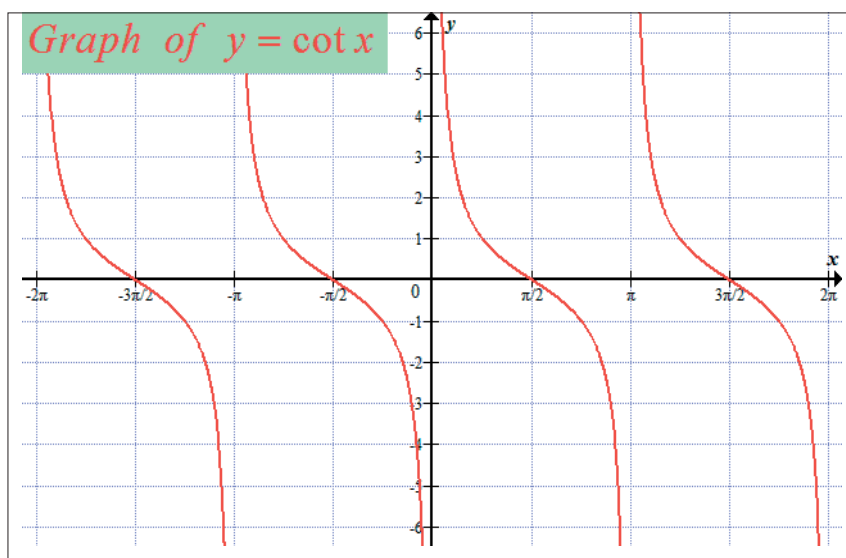

Secant and cosecant

Function $\sec x$ is not defined for $x = \pm \frac{\pi}{2}, \pm \frac{3\pi}{2}, \dots$

Generally, $\sec x$ is not defined for $x = \frac{\pi}{2} + k\pi, k \in \mathbb{Z}$.

Thus, similar to tangent, domain of $\sec x$ is $\mathbb{R} \setminus \left\{ \frac{\pi}{2} + k\pi \right\}, k \in \mathbb{Z}$.

Since $\sec x = \frac{1}{\cos x}$ and range of cosine is $[-1, 1]$, $\frac{1}{\cos x}$ will vary from negative infinity to -1 or from 1 to plus infinity. Thus, the range of $\sec x$ is $]-\infty, -1] \cup [1, +\infty[$

Function $\csc x$ is not defined for $x = 0, \pm\pi, \pm2\pi, \dots$. Generally, $\csc x$ is not defined for $x = k\pi, k \in \mathbb{Z}$. Thus, similar to cotangent, domain of $\csc x$ is $\mathbb{R} \setminus \{k\pi\}, k \in \mathbb{Z}$.

Since $\csc x = \frac{1}{\sin x}$ and range of sine is $[-1, 1]$, $\frac{1}{\sin x}$ will vary from minus infinity to -1 or from 1 to plus infinity. Thus, the range of $\csc x$ is $]-\infty, -1] \cup [1, +\infty[$

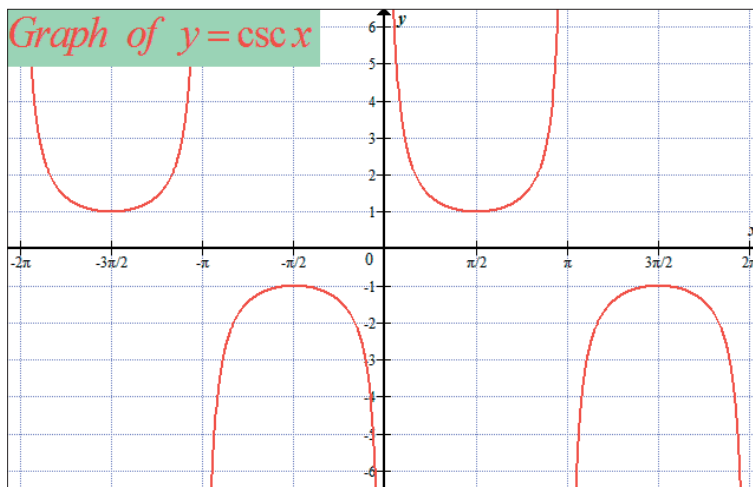
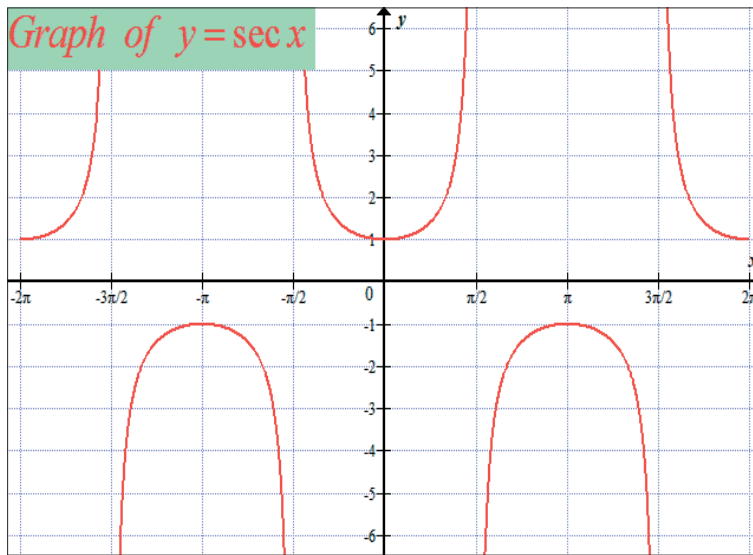

Application Activity 5.1

Find the domain of definition for each of the following functions:

1. $f(x) = \sin x + \cos x$
2. $f(x) = \sin \frac{1}{x}$
3. $f(x) = \cos \left(\frac{x+1}{x} \right)$
4. $f(x) = \frac{1}{x} + \sin 2x$
5. $f(x) = \cos x + \tan x$
6. $f(x) = \cos \frac{\sqrt{x}}{x}$

5.1.2. Domain and range of inverses of trigonometric functions



Activity 5.2

Use properties of inverse functions and state the values of x where the following functions are not defined

- | | | |
|----------------------|----------------------|----------------------|
| 1. $y = \sin^{-1} x$ | 2. $y = \cos^{-1} x$ | 3. $y = \tan^{-1} x$ |
| 4. $y = \cot^{-1} x$ | 5. $y = \sec^{-1} x$ | 6. $y = \csc^{-1} x$ |

Inverse sine and inverse cosine

$\sin x$ and $\cos x$ are defined on the entire interval $(-\infty, +\infty)$. They have the inverses called inverse sine and inverse cosine denoted by $\sin^{-1} x$ and $\cos^{-1} x$ respectively.

Note that the symbols $\sin^{-1} x$ and $\cos^{-1} x$ are never used to denote $\frac{1}{\sin x}$ and $\frac{1}{\cos x}$ respectively. If desired, $\frac{1}{\sin x}$ and $\frac{1}{\cos x}$ can be written as $(\sin x)^{-1}$ and $(\cos x)^{-1}$ (or $\csc x$ and $\sec x$) respectively.

In older literature, $\sin^{-1} x$ and $\cos^{-1} x$ are called **arcsine** of x and **arccosine** of x and they are denoted by $\arcsin x$ and $\arccos x$ respectively.

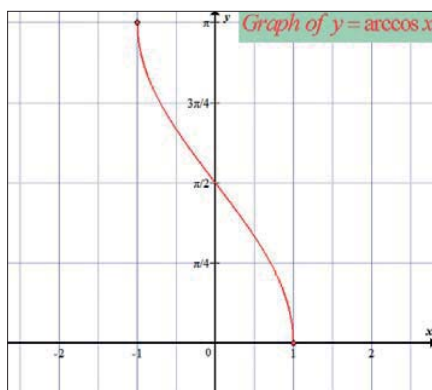
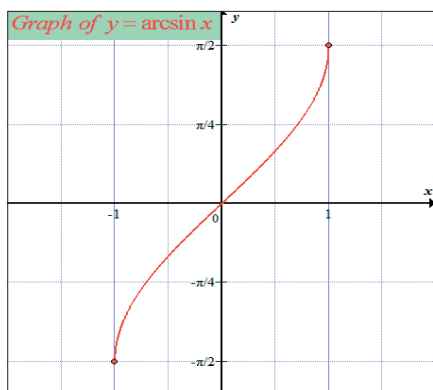

Remark

The inverses of the trigonometric functions are not functions, they are relations. The reason why they are not functions is that for one value of x , there are an infinite values of y (number of angles) at which the trigonometric functions take on the value of x . Thus,

the range of the inverses of the trigonometric functions must be restricted to make them functions. Without these restricted ranges, they are known as the inverse trigonometric relations.

To define $\sin^{-1} x$ and $\cos^{-1} x$, we restrict the domain of $\sin x$ and $\cos x$ to the interval $\left[-\frac{\pi}{2}, \frac{\pi}{2}\right]$ and $[0, \pi]$ respectively to obtain a one-to-one function.

There are other ways to restrict the domain of $\sin x$ and $\cos x$ to obtain one-to-one functions; we might have required that $\frac{3\pi}{2} \leq x \leq \frac{5\pi}{2}$ and $\pi \leq x \leq 2\pi$ (or $-\frac{5\pi}{2} \leq x \leq -\frac{3\pi}{2}$ and $-2\pi \leq x \leq -\pi$) respectively.

Because $\sin x$ (restricted) and $\sin^{-1} x$; $\cos x$ (restricted) and $\cos^{-1} x$ are inverses to each other, it follows that:

$$\odot \sin^{-1}(\sin y) = y \text{ if } -\frac{\pi}{2} \leq y \leq \frac{\pi}{2};$$

$$\sin(\sin^{-1} x) = x \text{ if } -1 \leq x \leq 1$$

$$\odot \cos^{-1}(\cos y) = y \text{ if } 0 \leq y \leq \pi;$$

$$\cos(\cos^{-1} x) = x \text{ if } -1 \leq x \leq 1$$

From these relations, we obtain the following important result:

Theorem 5.1

\odot If $-1 \leq x \leq 1$ and $-\frac{\pi}{2} \leq y \leq \frac{\pi}{2}$, then $y = \sin^{-1} x$ and $\sin y = x$ are equivalent.

\odot If $-1 \leq x \leq 1$ and $0 \leq y \leq \pi$, then $y = \cos^{-1} x$ and $\cos y = x$ are equivalent.

Example 5.1

Find

a) $\sin^{-1}\left(\frac{1}{2}\right)$

b) $\sin^{-1}\left(-\frac{1}{\sqrt{2}}\right)$

Solution

a) Let $y = \sin^{-1}\left(\frac{1}{2}\right)$. From Theorem 5.1, this equation is equivalent to $\sin y = \frac{1}{2}$, $-\frac{\pi}{2} \leq y \leq \frac{\pi}{2}$. The only value satisfying these conditions is $y = \frac{\pi}{6}$, so $\sin^{-1}\left(\frac{1}{2}\right) = \frac{\pi}{6}$

b) Let $y = \sin^{-1}\left(-\frac{1}{\sqrt{2}}\right)$. From Theorem 5.1, this equation is

equivalent to $\sin y = -\frac{1}{\sqrt{2}}$, $-\frac{\pi}{2} \leq y \leq \frac{\pi}{2}$. The only value satisfying these conditions is $y = -\frac{\pi}{4}$, so, $\sin^{-1}\left(-\frac{1}{\sqrt{2}}\right) = -\frac{\pi}{4}$.

Example 5.2

Simplify the function $\cos(\sin^{-1} x)$.

Solution

The idea is to express cosine in terms of sine in order to take advantage of the simplification $\sin^{-1}(\sin x) = x$.

Thus, we start by the identity $\cos^2 \theta = 1 - \sin^2 \theta$ and substitute $\theta = \sin^{-1} x$ to obtain $\cos^2(\sin^{-1} x) = 1 - \sin^2(\sin^{-1} x)$

Or by taking square root $|\cos(\sin^{-1} x)| = \sqrt{1 - \sin^2(\sin^{-1} x)}$

Or $|\cos(\sin^{-1} x)| = \sqrt{1 - x^2}$

Since $-\frac{\pi}{2} \leq \sin^{-1} x \leq \frac{\pi}{2}$, it follows that $\cos(\sin^{-1} x)$ is non-negative.

Thus, we can drop the absolute value and write $\cos(\sin^{-1} x) = \sqrt{1 - x^2}$

Inverse tangent

Tangent of x , denoted $\tan x$, is a function which is defined for all positive and negative values of x except $\pm 90^\circ, \pm 270^\circ, \dots$. The range of $\tan x$ is $(-\infty, +\infty)$. It has the inverse called **inverse tangent** and is denoted by $\tan^{-1} x$.

To define $\tan^{-1} x$, we restrict the domain of $\tan x$ to $\left(-\frac{\pi}{2}, \frac{\pi}{2}\right)$.

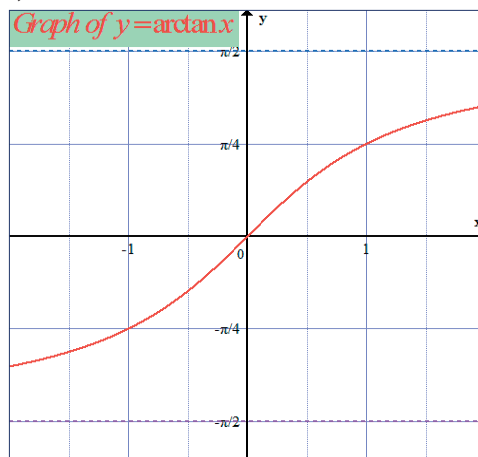

Because $\tan x$ (restricted) and $\tan^{-1} x$ are inverse to each other, it follows that

- ⊙ $\tan^{-1}(\tan y) = y$ if $-\frac{\pi}{2} < y < \frac{\pi}{2}$
- ⊙ $\tan(\tan^{-1} x) = x$ if $-\infty < x < +\infty$

From these relations, we obtain the following important result:

Theorem 5.2

- ⊙ If $-\infty < x < +\infty$ and $-\frac{\pi}{2} < y < \frac{\pi}{2}$, then $y = \tan^{-1} x$ and $\tan y = x$ are equivalents.

Example 5.3

Simplify the function $\sec^2(\tan^{-1} x)$

Solution

The idea is to express secant in terms of $\tan x$ to take the advantage of simplification $\tan(\tan^{-1} x) = x$.

Let $\theta = \tan^{-1} x$, in the identity $\sec^2 \theta = 1 + \tan^2 \theta$, we get

$$\sec^2(\tan^{-1} x) = 1 + \tan^2(\tan^{-1} x) = 1 + x^2$$

Thus, $\sec^2(\tan^{-1} x) = 1 + x^2$

Inverse secant

The inverse secant, denoted $\sec^{-1} x$, is defined to be the inverse of restricted secant function.

$$f(x) = \sec x, \quad 0 \leq x < \frac{\pi}{2} \text{ or } \frac{\pi}{2} < x \leq \pi.$$

If we let $y = \sec^{-1} x$, then we find that $x \leq -1$ or $x \geq 1$ and $0 \leq y < \frac{\pi}{2}$ or $\frac{\pi}{2} < y \leq \pi$.

Thus, the domain of $\sec^{-1} x$ is $(-\infty, -1] \cup [1, +\infty)$ and the range is

$$\left[0, \frac{\pi}{2} \left[\cup \right] \frac{\pi}{2}, \pi \right]$$

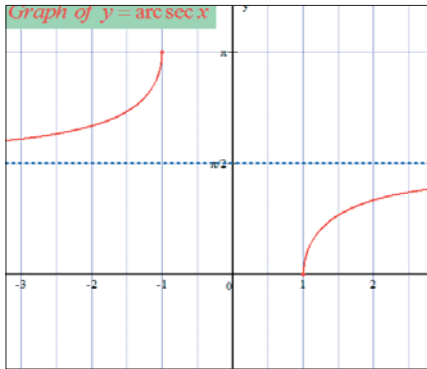

Theorem 5.3

If $x \leq -1$ or $x \geq 1$ and if $0 \leq y < \frac{\pi}{2}$ or $\frac{\pi}{2} < y \leq \pi$, then $y = \sec^{-1} x$ and $\sec y = x$ are equivalent statements.

Example 5.4

Simplify $\tan^2(\sec^{-1} x)$

Solution

We know that $\sec^2 \theta = 1 + \tan^2 \theta$, then $\tan^2 \theta = \sec^2 \theta - 1$

Putting $\theta = \sec^{-1} x$, we have $\tan^2(\sec^{-1} x) = \sec^2(\sec^{-1} x) - 1 = x^2 - 1$

Thus, $\tan^2(\sec^{-1} x) = x^2 - 1$

Inverse cotangent and inverse cosecant

We will summarise their properties briefly;

$y = \cot^{-1} x$ is equivalent to $x = \tan y$ if $0 < y < \pi$ and $-\infty < x < +\infty$

$y = \csc^{-1} x$ is equivalent to $x = \csc y$ if $-\frac{\pi}{2} \leq y < 0$ or $0 < y \leq \frac{\pi}{2}$ and $|x| \geq 1$

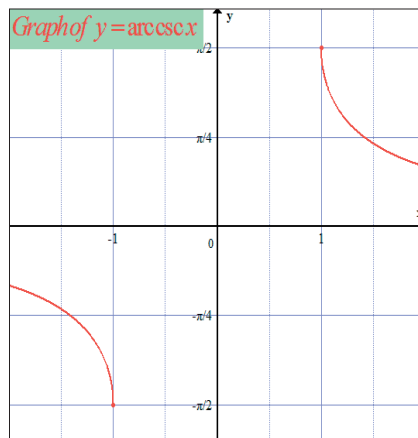
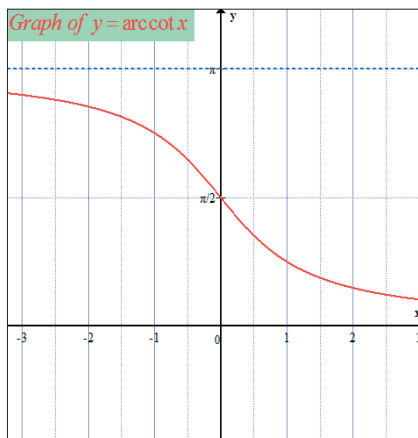



Notice

If α and β are acute complementary angles, then from basic trigonometry, $\sin \alpha$ and $\cos \beta$ are equal. Let us write $x = \sin \alpha = \cos \beta$ so that $\alpha = \sin^{-1} x$ and $\beta = \cos^{-1} x$. Since $\alpha + \beta = \frac{\pi}{2}$, we obtain the identity $\sin^{-1} x + \cos^{-1} x = \frac{\pi}{2}$. Similarly, we can obtain the identities

$$\tan^{-1} x + \cot^{-1} x = \frac{\pi}{2}$$

$$\sec^{-1} x + \csc^{-1} x = \frac{\pi}{2}$$

Remark

$$\sin^{-1}(-x) = -\sin^{-1} x$$

$$\tan^{-1}(-x) = -\tan^{-1} x$$

$$\sec^{-1}(-x) = \pi + \sec^{-1} x, \text{ if } x \geq 1$$

Example 5.5

For which values of x is true that

a) $\tan^{-1}(\tan x) = x$

b) $\tan(\tan^{-1} x) = x$

c) $\csc^{-1}(\csc x) = x$

d) $\csc(\csc^{-1} x) = x$

Solution

The values of x are:

a) $-\frac{\pi}{2} < x < \frac{\pi}{2}$

b) $-\infty < x < +\infty$

c) $-\frac{\pi}{2} \leq x < 0$ or $0 < x \leq \frac{\pi}{2}$

d) $|x| \geq 1$

Application Activity 5.2

Find the domain of definition of the following functions:

1. $f(x) = \frac{1}{x} + \sin^{-1} 2x$

2. $f(x) = \cos^{-1} x + \tan^{-1} x$

3. $f(x) = \cos^{-1} \frac{\sqrt{x}}{x}$

4. $f(x) = \sin^{-1} \frac{1}{x}$

5.1.3. Parity of trigonometric functions

Activity 5.3



For the function

1. $f(x) = \frac{\sin x}{x}$, find $f(-x)$, $-f(x)$ and compare the two results to $f(x)$.
2. $g(x) = \frac{\cos x}{x}$, find $g(-x)$, $-g(x)$ and compare the two results to $g(x)$.
3. $h(x) = \sin x + \cos x$, find $h(-x)$, $-h(x)$ and compare the two results to $h(x)$.

Even functions

A function $f(x)$ is said to be **even** if the following conditions are satisfied:

- ⊙ $\forall x \in \text{Dom}f, -x \in \text{Dom}f$
- ⊙ $f(-x) = f(x)$

The graph of such function is **symmetric about the vertical axis**.
i.e $x=0$

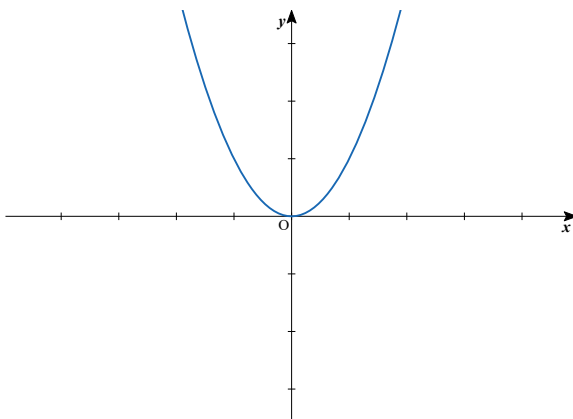

Example 5.6

The function $\cos x$ is an even function since $\forall x \in \mathbb{R}, -x \in \mathbb{R}$ and $f(-x) = \cos(-x) = \cos x = f(x)$

Odd function

A function $f(x)$ is said to be **odd** if the following conditions are satisfied

- ⊙ $\forall x \in \text{Dom}f, -x \in \text{Dom}f$
- ⊙ $f(-x) = -f(x)$

The graph of such function looks the same when rotated through half a revolution about 0. This is called **rotational symmetry**.

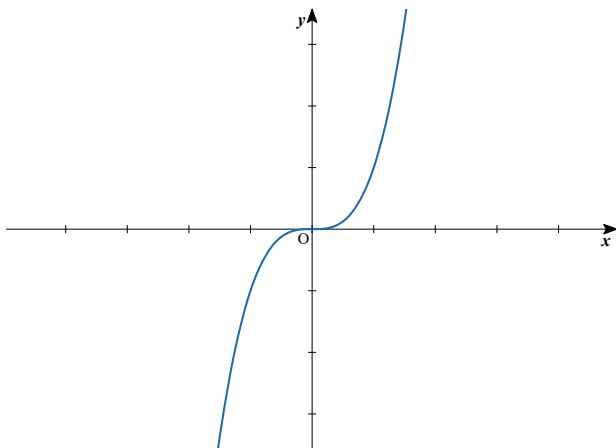

Example 5.7

The function $\sin x$ is an odd function since $\forall x \in \mathbb{R}, -x \in \mathbb{R}$ and $f(-x) = \sin(-x) = -\sin x = -f(x)$

Application Activity 5.3

Study the parity of the following functions:

1. $f(x) = \frac{x^2}{\cos x}$

2. $f(x) = x + \sin 4x$

3. $f(x) = \sqrt[3]{x} + \sin x$

4. $f(x) = \frac{\tan x}{x+1}$

Period of trigonometric functions

Activity 5.4



What would be the value(s) of P to make the following relations true?

1. $\sin(x + P) = \sin x$
2. $\cos(x + P) = \cos x$
3. $\tan(x + P) = \tan x$

A function f is called **periodic** if there is a positive number P such that $f(x + P) = f(x)$ whenever x and $x + P$ lie in the domain of f .

We call P a **period** of the function. The smallest positive period is called the **fundamental period** (also **primitive period**, **basic period**, or **prime period**) of f .

A function with period P repeats on intervals of length P , and these intervals are referred to as **periods**.

Geometrically, a periodic function can be defined as a function whose graph exhibits translational symmetry. Specifically, a function is periodic with period P if its graph is invariant under translation in the x -direction by a distance of P .

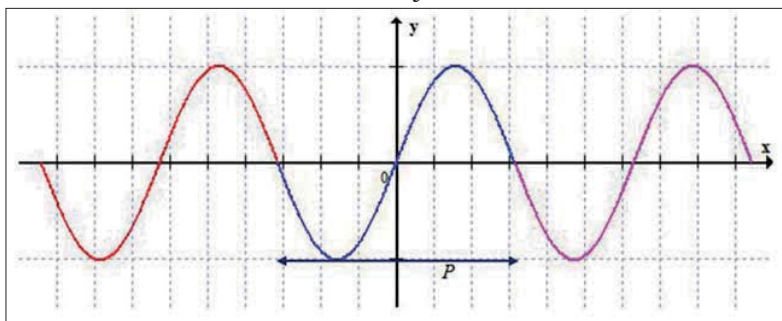

The most important examples of periodic functions are the trigonometric functions.

Any function which is not periodic is called **aperiodic**.

Example 5.8

a) For the sine and cosine functions, 2π is the period since

$$\sin(x + 2\pi) = \sin x \text{ and } \cos(x + 2\pi) = \cos x.$$

Also $4\pi, 6\pi, 8\pi, \dots$, are periods for sine and cosine functions since

$\sin(x+4\pi) = \sin x, \sin(x+6\pi) = \sin x, \sin(x+8\pi) = \sin x, \dots$ and
 $\cos(x+4\pi) = \cos x, \cos(x+6\pi) = \cos x, \cos(x+8\pi) = \cos x, \dots$

The fundamental period of sine and cosine functions is 2π .

b) For tangent and cotangent functions, π is a period since

$\tan(x+\pi) = \tan x$ and $\cot(x+\pi) = \cot x$. Also $2\pi, 3\pi, 4\pi, \dots$ are periods, but π is the fundamental period.

Or using definition, and solving for P;

For $\sin x$, we have $\sin(x+P) = \sin x \Leftrightarrow x+P = x+2k\pi, k$ integer

$\Leftrightarrow P = 2k\pi$. Since we need the smallest positive period, we take $k=1$

Thus, $P = 2\pi$.

For $\cos x$, we have $\cos(x+P) = \cos x \Leftrightarrow x+P = x+2k\pi, k \in \mathbb{Z}$

$\Leftrightarrow P = 2k\pi$. Since we need the smallest positive period, we take $k=1$

Thus, $P = 2\pi$.

For $\tan x$, we have $\tan(x+P) = \tan x \Leftrightarrow x+P = x+k\pi, k \in \mathbb{Z}$

$\Leftrightarrow P = k\pi$. Since we need the smallest positive period, we take $k=1$

Thus, $P = \pi$.

Example 5.9

For $\sin 3x$ and $\cos 3x$ functions, the fundamental period is $\frac{2\pi}{3}$

since $\sin\left[3\left(x+\frac{2\pi}{3}\right)\right] = \sin(3x+2\pi) = \sin 3x$ and

$\cos\left[3\left(x+\frac{2\pi}{3}\right)\right] = \cos(3x+2\pi) = \cos 3x$.

Theorem 5.4

If $a \neq 0$ and $b \neq 0$, then the functions $a \sin bx$ and $a \cos bx$ have fundamental period $\frac{2\pi}{|b|}$ and their graphs oscillate between $-a$ and a . The number $|a|$ is called the amplitude of the function.

Example 5.10

Find the fundamental period of $f(x) = 2 \sin 6x$ and $g(x) = 4 \cos 3x$

For $f(x)$, we have $2\sin 6(x+P) = 2\sin 6x$

$$\Leftrightarrow 6x+6P = 6x+2k\pi, k \in \mathbb{Z}$$

$$\Leftrightarrow 6P = 2k\pi.$$

Since we need the smallest positive period, we take $k = 1$

$$\text{Thus, } P = \frac{\pi}{3}.$$

For $g(x)$, we have $4\cos 3(x+P) = 4\sin 3x$

$$\Leftrightarrow 3x+3P = 3x+2k\pi, k \in \mathbb{Z}$$

$$\Leftrightarrow 3P = 2k\pi.$$

Since we need the smallest positive period, we take $k = 1$

$$\text{Thus, } P = \frac{2\pi}{3}.$$

Application Activity 5.4

Find the fundamental period of the following functions:

1. $f(x) = \sin 2x$

2. $f(x) = \cos\left(\frac{2x}{3}\right)$

3. $g(x) = \tan 3x$

4. $h(t) = 2\sin t$

5. $f(t) = \sin(\omega t + \varphi)$

6. $f(x) = \tan(2x+3)$

Combining periodic functions



Activity 5.5

Find the Lowest Common Multiple of:

1. π and 2π

2. $\frac{\pi}{2}$ and π

3. $\frac{2\pi}{3}$ and $\frac{\pi}{7}$

We have seen that *sine* and *cosine* are both periodic and have the same period. When we add them up, subtract them, multiply them, etc we get functions that are also periodic.

To see this:

Let us assume that $f(x+kP) = f(x)$ is true for all real x , k integers.

Simply multiplying each side by some constant does not change the equation and adding or subtracting some constant to each side does not change periodicity.

If we have two functions $f(x)$ and $g(x)$ with the same period, say P , we can throw them together any way we want.

Let $h(x) = f(x) + g(x)$, at any value a of x :

$$h(a) = f(a) + g(a) = c$$

$$h(a + kP) = f(a + kP) + g(a + kP) = c$$

Thus, $h(a) = h(a + kP)$.

This is different for functions that don't have the same fundamental period:

Let us say that we have two periodic functions $f(x)$ and $g(x)$ with period P and Q respectively:

$$f(x + kP) = f(x) \text{ is true for all real } x, k \text{ integers.}$$

$$g(x + kQ) = g(x) \text{ is true for all real } x, k \text{ integers.}$$

Now, we cannot construct that nice $h(x)$ as we did before because we have different periods.

Consider the following case:

If a function repeats every 2 units, then it will also repeat every 6 units. So, if we have one function with fundamental period 2, and another function with fundamental period 8, we have got no problem because 8 is a multiple of 2, and both functions will cycle every 8 units.

So, if we can patch up the periods to be the same, we know that if we combine them, we will get a function with the patched up period.

What we have to do is to find the Lowest Common Multiple (LCM) of two periods.

What about if one function has period 4 and another has period 5? We can see that in 20 units, both will cycle, so they are fine.

Example 5.11

Find the fundamental period of the function

$$f(x) = \tan\left(\frac{x+1}{2}\right) \sin\left(\frac{2x+1}{5}\right)$$

Solution

$$\text{For } \tan\left(\frac{x+1}{2}\right), P_1 = 2\pi$$

$$\text{For } \sin\left(\frac{2x+1}{5}\right), P_2 = 5\pi$$

$$LCM(2\pi, 5\pi) = 10\pi, P = 10\pi$$

“When the periods are fractional, we use the LCM rule which states that $LCM\left(\frac{a}{b}, \frac{c}{d}\right) = \frac{LCM(a, c)}{HCF(b, d)}$, where $b \neq 0, d \neq 0$ ”, provided the function is not even, among the conditions.

Theorem 5.5

If two periodic functions have rational periods, then any addition or multiplication combination of those functions (not composition) will also be periodic.

Also, if $f(x)$ is a periodic function and $g(x)$ is not a periodic function, then $g(f(x))$ is periodic and $f(g(x))$ is not.

Example 5.12

Find the fundamental period of the function $f(x) = \frac{\sin 3x}{\tan 7x}$

Solution

$$\text{For } \sin 3x, P_1 = \frac{2\pi}{3}$$

$$\text{For } \tan 7x, P_2 = \frac{\pi}{7}$$

P_1 is 2π in 3 fundamental periods

P_2 is π in 7 fundamental periods

But 2π is a multiple of π

Thus, $P = 2\pi$.

Example 5.13

Find the fundamental period of the function $f(x) = \sin x + \sin 4x$

Solution

For $\sin x$, $P_1 = 2\pi$

For $\sin 4x$, $P_2 = \frac{\pi}{2}$

$$P = LCM\left(2\pi, \frac{\pi}{2}\right)$$

$$P = 2\pi$$

Application Activity 5.5

Find the fundamental period of the following functions:

1. $f(x) = 3\sin 2x - \tan 5x$

2. $f(x) = \sqrt{2}\sin 4x + \sin 5x$

3. $f(x) = \cos x - \tan 2x$

4. $f(x) = \cos \sqrt{3}x + \sin 6x$

5.2. Limits of trigonometric functions and their inverses

5.2.1. Limits of trigonometric functions

**Activity 5.6**

1. Evaluate

a) $\lim_{x \rightarrow 0} \sin x$

b) $\lim_{x \rightarrow 0} x \sin x$

c) $\lim_{x \rightarrow 0} \cos x$

d) $\lim_{x \rightarrow 0} \frac{1}{x}$

e) $\lim_{x \rightarrow 0} \frac{\cos x}{x}$

2. Consider the function $f(x) = \frac{\sin x}{x}$ where x is in radians.

Use calculator to complete the following tables

x	$\frac{\sin x}{x}$
1	
0.9	
0.8	
0.7	
0.6	
0.5	
0.4	
0.3	
0.2	
0.1	
0.01	
0.001	
0.0001	

x	$\frac{\sin x}{x}$
-1	
-0.9	
-0.8	
-0.7	
-0.6	
-0.5	
-0.4	
-0.3	
-0.2	
-0.1	
-0.01	
-0.001	
-0.0001	

- a) From results in 2), what is the limit of $\frac{\sin x}{x}$ as x approaches 0 from the right side?
- b) From results in 2), what is the limit of $\frac{\sin x}{x}$ as x approaches 0 from the left side?
- c) What can you say about $\lim_{x \rightarrow 0} \frac{\sin x}{x}$?

From Activity 5.6,

$$\lim_{x \rightarrow 0} \frac{\sin x}{x} = 1$$

There is another way to prove this.

Let us consider the unit circle below:

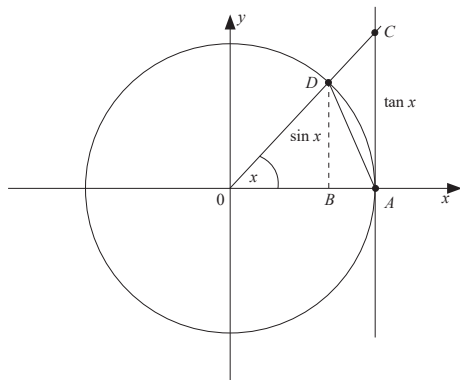

Assume $0 < x < \frac{\pi}{2}$. Since the circle is unit circle, the radius $\overline{OA} = 1$.

The area of the triangle OAD is $\frac{1}{2} \overline{OA} \sin x = \frac{1}{2} \sin x$

The area of the sector OAD :

Recall that the area of a sector with subtended angle measuring x radian is $A = \frac{x}{2} r^2$, where r is the radius. The subtended angle of sector OAD is x and radius is r , the area of the sector OAD is $\frac{1}{2} \overline{OA}^2 x = \frac{1}{2} x$

The area of the triangle OAC is $\frac{1}{2} \overline{OA} \tan x = \frac{1}{2} \tan x$

From the figure, we see that

area of $\triangle OAD \leq$ area of sector $OAD \leq$ area of $\triangle OAC$

Or $\frac{1}{2} \sin x \leq \frac{1}{2} x \leq \frac{1}{2} \tan x \Leftrightarrow \sin x \leq x \leq \frac{\sin x}{\cos x}$

Dividing by $\sin x$, we get $1 \leq \frac{x}{\sin x} \leq \frac{1}{\cos x}$

Taking the inverse [remember that when taking the inverse, the order of the inequality must be changed], we get $\cos x \leq \frac{\sin x}{x} \leq 1$

Taking limit as x approaches 0, we get $1 \leq \lim_{x \rightarrow 0} \frac{\sin x}{x} \leq 1$

Using **squeeze theorem**, since $\cos x \leq \frac{\sin x}{x} \leq 1$ and

$\lim_{x \rightarrow 0} \cos x = \lim_{x \rightarrow 0} 1 = 1$ then $\lim_{x \rightarrow 0} \frac{\sin x}{x} = 1$

Thus, $\lim_{x \rightarrow 0} \frac{\sin x}{x} = 1$

This result will help us to find limit of some other trigonometric functions

Example 5.14

Evaluate $\lim_{x \rightarrow 0} \frac{1 - \cos x}{x}$

Solution

$$\lim_{x \rightarrow 0} \frac{1 - \cos x}{x} = \frac{0}{0} \quad \text{Indeterminate case (I.C.)}$$

$$\begin{aligned} \lim_{x \rightarrow 0} \frac{1 - \cos x}{x} &= \lim_{x \rightarrow 0} \frac{2 \sin \frac{x}{2} \sin \frac{x}{2}}{x} \quad \text{we know that } \left[1 - \cos x = 2 \sin^2 \frac{x}{2} \right] \\ &= \lim_{x \rightarrow 0} \frac{2 \sin \frac{x}{2}}{x} \lim_{x \rightarrow 0} \sin \frac{x}{2} = \lim_{x \rightarrow 0} \frac{2 \sin \frac{x}{2}}{2 \frac{x}{2}} \lim_{x \rightarrow 0} \sin \frac{x}{2} \\ &= \lim_{x \rightarrow 0} \frac{\sin \frac{x}{2}}{\frac{x}{2}} \lim_{x \rightarrow 0} \sin \frac{x}{2} \\ &= 1 \times 0 \\ &= 0 \end{aligned}$$

$$\text{Thus, } \lim_{x \rightarrow 0} \frac{1 - \cos x}{x} = 0$$

Example 5.15

Evaluate $\lim_{x \rightarrow 0} \frac{x}{\sin x}$

Solution

$$\lim_{x \rightarrow 0} \frac{x}{\sin x} = \frac{0}{0} \quad \text{I.C.}$$

$$\begin{aligned} \lim_{x \rightarrow 0} \frac{x}{\sin x} &= \lim_{x \rightarrow 0} \frac{x}{x \frac{\sin x}{x}} \\ &= \lim_{x \rightarrow 0} \frac{1}{\frac{\sin x}{x}} = \frac{\lim_{x \rightarrow 0} 1}{\lim_{x \rightarrow 0} \frac{\sin x}{x}} \\ &= \frac{1}{1} = 1 \end{aligned}$$

$$\text{Thus, } \lim_{x \rightarrow 0} \frac{x}{\sin x} = 1$$

Example 5.16

Evaluate $\lim_{x \rightarrow 0} \frac{\tan x}{x} = 1$

Solution

$$\lim_{x \rightarrow 0} \frac{\tan x}{x} = \frac{0}{0} \text{ I.C}$$

$$\begin{aligned} \lim_{x \rightarrow 0} \frac{\tan x}{x} &= \lim_{x \rightarrow 0} \frac{\sin x}{x \cos x} \\ &= \lim_{x \rightarrow 0} \frac{\sin x}{x} \frac{1}{\cos x} = \lim_{x \rightarrow 0} \frac{\sin x}{x} \lim_{x \rightarrow 0} \frac{1}{\cos x} \\ &= 1 \times 1 = 1 \end{aligned}$$

$$\text{Thus, } \lim_{x \rightarrow 0} \frac{\tan x}{x} = 1$$

Example 5.17

Evaluate $\lim_{x \rightarrow 0} \frac{\cot x}{x}$

Solution

$$\lim_{x \rightarrow 0} \frac{\cot x}{x} = \frac{\infty}{0} = \infty$$

Or

$$\lim_{x \rightarrow 0} \frac{\cot x}{x} = \lim_{x \rightarrow 0} \cot x \lim_{x \rightarrow 0} \frac{1}{x} = \infty \times \infty = \infty$$

Left and right hand limits: $\frac{\cot x}{x} = \frac{\cos x}{x \sin x} = \frac{\cos x}{x \sin x}$

x	$-\frac{\pi}{2}$	0	$\frac{\pi}{2}$
$\cos x$	$+$	1	$+$
x	$-$	0	$+$
$\sin x$	$-$	0	$+$
$x \sin x$	$+$	0	$+$
$\frac{\cos x}{x \sin x}$	$+$	$\frac{0}{0}$ ∞	$+$

Thus, $\lim_{x \rightarrow 0^+} \frac{\cot x}{x} = +\infty$ and $\lim_{x \rightarrow 0^-} \frac{\cot x}{x} = +\infty$ and hence

$\lim_{x \rightarrow 0} \frac{\cot x}{x}$ **does not exist.**

When finding limits of trigonometric functions, sometimes we need to change the variable.

Example 5.18

Evaluate $\lim_{x \rightarrow \frac{\pi}{3}} \frac{1-2\cos x}{x-\frac{\pi}{3}}$

Solution

$$\lim_{x \rightarrow \frac{\pi}{3}} \frac{1-2\cos x}{x-\frac{\pi}{3}} = \frac{1-2 \times \frac{1}{2}}{\frac{\pi}{3}-\frac{\pi}{3}} = \frac{0}{0} \text{ I.C}$$

Let $x - \frac{\pi}{3} = t \Rightarrow x = t + \frac{\pi}{3}$. If $x \rightarrow \frac{\pi}{3}$, $t \rightarrow 0$

$$\begin{aligned} \lim_{t \rightarrow 0} \frac{1-2\cos\left(t+\frac{\pi}{3}\right)}{t} &= \lim_{t \rightarrow 0} \frac{1-2\left(\cos t \cos \frac{\pi}{3}-\sin t \sin \frac{\pi}{3}\right)}{t} \\ &= \lim_{t \rightarrow 0} \frac{1-2\left(\frac{1}{2}\cos t-\frac{\sqrt{3}}{2}\sin t\right)}{t} \\ &= \lim_{t \rightarrow 0} \frac{1-\cos t+\sqrt{3}\sin t}{t} \\ &= \lim_{t \rightarrow 0} \left(\frac{1-\cos t}{t}+\frac{\sqrt{3}\sin t}{t}\right) \\ &= \lim_{t \rightarrow 0} \frac{1-\cos t}{t} + \lim_{t \rightarrow 0} \frac{\sqrt{3}\sin t}{t} \\ &= \lim_{t \rightarrow 0} \frac{1-\cos t}{t} + \sqrt{3} \lim_{t \rightarrow 0} \frac{\sin t}{t} \\ &= 0 + \sqrt{3} \times 1 \\ &= \sqrt{3} \end{aligned}$$

Example 5.19

Evaluate $\lim_{x \rightarrow 3} \frac{x-3}{\sin \pi x}$

Solution

$$\lim_{x \rightarrow 3} \frac{x-3}{\sin \pi x} = \frac{0}{0} \text{ I.C}$$

Let $t = x - 3 \Rightarrow x = t + 3$. If $x \rightarrow 3$, $t \rightarrow 0$

$$\begin{aligned}\lim_{x \rightarrow 3} \frac{x-3}{\sin \pi x} &= \lim_{t \rightarrow 0} \frac{t}{\sin(\pi t + 3\pi)} = \lim_{t \rightarrow 0} \frac{t}{\sin \pi t \cos 3\pi + \cos \pi t \sin 3\pi} \\ &= \lim_{t \rightarrow 0} \frac{t}{-\sin \pi t} \quad [\text{Since } \cos 3\pi = -1, \sin 3\pi = 0] \\ &= -\lim_{t \rightarrow 0} \frac{\frac{t}{\pi t}}{\frac{\sin \pi t}{\pi t}} = -\lim_{t \rightarrow 0} \frac{1}{\sin \pi t} = -\frac{1}{\pi}\end{aligned}$$

Application Activity 5.6

Find the limit of the following functions:

- $\lim_{\theta \rightarrow \frac{\pi}{4}} (\theta \tan \theta)$
- $\lim_{x \rightarrow \frac{\pi}{2}} \frac{\cos^2 x}{1 - \sin x}$
- $\lim_{t \rightarrow 0} \frac{1 - \cos t}{\sin t}$
- $\lim_{t \rightarrow 0} \frac{\sin 3t}{t}$

5.2.2. Limits of inverse trigonometric functions



Activity 5.7

1. Find the exact value of;

- | | | |
|--------------------|--------------------|--------------------|
| a) $\sin^{-1}(-1)$ | b) $\tan^{-1}(1)$ | c) $\cot^{-1}(-1)$ |
| d) $\sec^{-1}(-2)$ | e) $\csc^{-1}(-2)$ | |

2. Evaluate the following limits;

- | | |
|--|---|
| a) $\lim_{x \rightarrow 1} \cot^{-1}\left(\frac{2x-3}{x}\right)$ | b) $\lim_{x \rightarrow 1} \sin^{-1}\left(\frac{1+x}{2x}\right)$ |
| c) $\lim_{x \rightarrow 0} \cos^{-1}\left(\frac{\sqrt{x+1}-1}{x}\right)$ | d) $\lim_{x \rightarrow -1} \tan^{-1}\left(\frac{1-x^2}{2x+2}\right)$ |

We can also evaluate the limits of inverse trigonometric functions. We find the numerical value of the given function at given value and see if the result is indeterminate case or not. One of the methods used to remove indeterminate case is l'Hôpital's rule:

Recall that if $\lim_{x \rightarrow a} \frac{f(x)}{g(x)} = \frac{0}{0}$ or $\lim_{x \rightarrow a} \frac{f(x)}{g(x)} = \frac{\infty}{\infty}$, we remove this

indeterminate case by differentiating function $f(x)$ and $g(x)$ and then evaluate the limit. That is, if $\lim_{x \rightarrow a} \frac{f(x)}{g(x)} = \frac{0}{0}$ or $\lim_{x \rightarrow a} \frac{f(x)}{g(x)} = \frac{\infty}{\infty}$ then we evaluate $\lim_{x \rightarrow a} \frac{f'(x)}{g'(x)}$. We do this until

the indeterminate case is removed. Other methods used to remove indeterminate cases are also applied.

Example 5.20

Evaluate $\lim_{x \rightarrow +\infty} \sin^{-1}\left(\frac{1}{x}\right)$

Solution

$$\begin{aligned} \lim_{x \rightarrow +\infty} \sin^{-1}\left(\frac{1}{x}\right) &= \sin^{-1}\left(\frac{1}{\infty}\right) \\ &= \sin^{-1}(0) \\ &= 0 \end{aligned}$$

Example 5.21

Evaluate $\lim_{x \rightarrow \frac{1}{2}} x \sin^{-1} x$

Solution

$$\begin{aligned} \lim_{x \rightarrow \frac{1}{2}} x \sin^{-1} x \\ &= \frac{1}{2} \sin^{-1} \frac{1}{2} \\ &= \frac{\pi}{12} \end{aligned}$$

Example 5.22

Evaluate $\lim_{x \rightarrow +\infty} \tan^{-1}(x^2 - 2x + 5)$

Solution

$$\lim_{x \rightarrow +\infty} \tan^{-1}(x^2 - 2x + 5) = \tan^{-1}(\infty - \infty) \text{ I.C.}$$

Remove this I.C,

$$\begin{aligned}
 \lim_{x \rightarrow +\infty} \tan^{-1}(x^2 - 2x + 5) &= \lim_{x \rightarrow +\infty} \tan^{-1} x^2 \left(1 - \frac{2}{x} + \frac{5}{x^2} \right) \\
 &= \tan^{-1} \left[\infty \left(1 - \frac{2}{\infty} + \frac{5}{\infty} \right) \right] \\
 &= \tan^{-1}(\infty) \\
 &= \frac{\pi}{2}
 \end{aligned}$$

Application Activity 5.7

Evaluate the following limits:

1. $\lim_{x \rightarrow 1} \left(\frac{\pi}{2} - \tan^{-1} \frac{1}{x} \right)$

2. $\lim_{x \rightarrow 1^-} (x-2) \tan^{-1} \frac{1}{1-x}$

3. $\lim_{x \rightarrow 0} \frac{\sin x}{\sin^{-1} x}$

4. $\lim_{x \rightarrow 1} \frac{\cos^{-1} x - \tan^{-1}(1-x)}{x^2 - 1}$

5. $\lim_{x \rightarrow 0} \frac{\sin^{-1} 5x}{x}$

6. $\lim_{x \rightarrow +\infty} x \tan^{-1} \frac{2}{x}$

5.3. Differentiation of trigonometric functions and their inverses

5.3.1. Derivative of sine and cosine



Activity 5.8

- Using definition of derivative, find the derivative of $\sin x$.
- Use result in 1) and relation $\cos x = \sin\left(\frac{\pi}{2} - x\right)$ to find the derivative of $\cos x$.

The functions $f(x) = \sin x$ and $f(x) = \cos x$ are differentiable on the set of real numbers. In addition, From Activity 5.8,

$$(\sin x)' = \cos x \quad \text{and} \quad (\cos x)' = -\sin x.$$

After differentiation of composite functions, if u is another function, then $(\sin u)' = u' \cos u$ and $(\cos u)' = -u' \sin u$

Example 5.23

Find the derivative of $f(x) = \sin(3x^2 + 4)$

Solution

$$\begin{aligned} f'(x) &= (3x^2 + 4)' \cos(3x^2 + 4) \\ &= 6x \cos(3x^2 + 4) \end{aligned}$$

Example 5.24

Find the derivative of $f(x) = \cos(3x)$

Solution

$$\begin{aligned} f'(x) &= -(3x)' \sin(3x) \\ &= -3 \sin(3x) \end{aligned}$$

Application Activity 5.8

Find the derivative of the following functions:

1. $f(x) = \sin(x^2 + 3)$
2. $f(x) = \sin^3(x^2 + 4)$
3. $f(x) = \cos 3x^2$
4. $f(x) = \cos^3 2x$

Derivative of tangent and cotangent**Activity 5.9**

1. Use the rule for derivative of a quotient and the relation $\tan x = \frac{\sin x}{\cos x}$ to find the derivative of $\tan x$.
2. Use result in 1) and relation $\cot x = \tan\left(\frac{\pi}{2} - x\right)$ to find the derivative of $\cot x$.

The function $f(x) = \tan x$ is differentiable on $\mathbb{R} \setminus \left\{ \frac{\pi}{2} + k\pi \right\}, k \in \mathbb{Z}$
and the function $f(x) = \cot x$ is

differentiable on $\mathbb{R} \setminus \{k\pi\}, k \in \mathbb{Z}$.

In addition, From Activity 5.9.

$$\forall x \neq \frac{\pi}{2} + k\pi, k \in \mathbb{Z}$$

$$\begin{aligned} (\tan x)' &= \frac{1}{\cos^2 x} \\ &= \sec^2 x \\ &= 1 + \tan^2 x \end{aligned}$$

Thus, $(\tan x)' = 1 + \tan^2 x$

If u is another function then,

$$\begin{aligned} (\tan u)' &= \frac{u'}{\cos^2 u} \\ &= u' \sec^2 u \\ &= u'(1 + \tan^2 u) \end{aligned}$$

Thus, $(\tan u)' = u'(1 + \tan^2 u)$

$$\forall x \neq k\pi, k \in \mathbb{Z}$$

$$\begin{aligned} (\cot x)' &= \frac{-1}{\sin^2 x} \\ &= -\csc^2 x \\ &= -(1 + \cot^2 x) \end{aligned}$$

Thus, $(\cot x)' = -(1 + \cot^2 x)$

If u is another function then,

$$\begin{aligned} (\cot u)' &= \frac{-u'}{\sin^2 u} \\ &= -u' \csc^2 u \\ &= -u'(1 + \cot^2 u) \end{aligned}$$

Thus, $(\cot u)' = -u'(1 + \cot^2 u)$

Example 5.25

Find the derivative of $f(x) = x^2 \tan x$

Solution

$$\begin{aligned} f'(x) &= (x^2)' \tan x + x^2 (\tan x)' \\ &= 2x \tan x + x^2 \sec^2 x \end{aligned}$$

Example 5.26

Find the derivative $f(x) = \cot x^2$

Solution

$$\begin{aligned} f'(x) &= -(x^2)' \csc^2 x^2 \\ &= -2x \csc^2 x^2 \end{aligned}$$

Application Activity 5.9

Find the derivative of the following functions:

- $f(x) = x \tan x$
- $f(x) = \tan(3x + 2)$
- $f(x) = \cot(x^2 - 5)$
- $f(x) = \sin x \cot 4x$

Derivative of secant and cosecant

Activity 5.10



1. Use the rule for derivative of reciprocal of a function and relation $\sec x = \frac{1}{\cos x}$ to find the derivative of $\sec x$.
2. Use rule for derivative of reciprocal of a function and relation $\csc x = \frac{1}{\sin x}$ to find the derivative of $\csc x$.

From Activity 5.10,

$$(\sec x)' = \sec x \tan x \quad \text{and} \quad (\csc x)' = -\csc x \cot x$$

If u is another function,

$$\text{then } (\sec u)' = u' \sec u \tan u \quad \text{and} \quad (\csc u)' = -u' \csc u \cot u$$

Example 5.27

Find the derivative of $f(x) = \sec(2x+1)$

Solution

$$f'(x) = 2 \sec(2x+1) \tan(2x+1)$$

Example 5.28

Find the derivative of $f(x) = \csc(x^2+1)$

Solution

$$f'(x) = -\csc(x+1) \cot(x+1)$$

Application Activity 5.10

Find the derivative of the following functions:

1. $f(x) = \sec(3x+2)$
2. $f(\theta) = \theta^3 \csc 2\theta$
3. $f(x) = \sec^4 3x$

5.3.2. Differentiation of inverse trigonometric functions

Derivative of inverse sine and inverse cosine



Activity 5.11

1. We know that $f(x) = \sin^{-1} x$ for $x \in [-1, 1]$ and $x = \sin y$ for $y \in \left[-\frac{\pi}{2}, \frac{\pi}{2}\right]$ where $y = f(x)$. Use the rule for derivative of composite functions to find the derivative of $\sin^{-1} x$, the inverse of sine function.
2. We also know that $f(x) = \cos^{-1} x$ for $x \in [-1, 1]$ and $x = \cos y$ for $y \in [0, \pi]$ where $y = f(x)$. Use the rule for derivative of composite functions: if $u(x)$ and $v(x)$ are functions differentiable at x and at $u(x)$, respectively, then $v \circ u$ is differentiable at x and $(v \circ u)'(x) = v'[u(x)]u'(x)$ to find the derivative of $\cos^{-1} x$, the inverse of cosine function.

From Activity 5.10

$$\forall x \in]-1, 1[, \quad (\sin^{-1} x)' = \frac{1}{\sqrt{1-x^2}} \quad \text{and} \quad (\cos^{-1} x)' = \frac{-1}{\sqrt{1-x^2}}$$

If u is another function, $(\sin^{-1} u)' = \frac{u'}{\sqrt{1-u^2}}$ and $(\cos^{-1} u)' = \frac{-u'}{\sqrt{1-u^2}}$

Example 5.29

Find the derivative of $f(x) = \sin^{-1} x^3$

Solution

$$f'(x) = \frac{(x^3)'}{\sqrt{1-(x^3)^2}} = \frac{3x^2}{\sqrt{1-x^6}}$$

Example 5.30

Find the derivative of $f(x) = \cos^{-1}(2x+1)$

Solution

$$\begin{aligned}
 f'(x) &= \frac{-(2x+1)'}{\sqrt{1-(2x+1)^2}} \\
 &= \frac{-2}{\sqrt{1-4x^2-4x-1}} \\
 &= \frac{-1}{\sqrt{-x^2-x}}
 \end{aligned}$$

Example 5.31

Find the derivative of $y = \sin^{-1}(1-x^2)$

Solution

$$y' = \frac{-2x}{\sqrt{1-(1-x^2)^2}} = \frac{-2x}{\sqrt{-x^4+2x^2}}$$

Example 5.32

Find the derivative of $y = 3 \cos^{-1}(x^2 + 0.5)$

Solution

$$y' = 3 \frac{-2x}{\sqrt{1-(x^2+0.5)^2}} = \frac{-6x}{\sqrt{0.75-x^2-x^4}}$$

Example 5.33

Find the derivative of $y = (x^2+1) \sin^{-1} 4x$

Solution

$$y' = \frac{4(x^2+1)}{\sqrt{1-(4x)^2}} + 2x \sin^{-1} 4x$$

Application Activity 5.11

Find the derivative of the following functions:

- $f(x) = \cos^{-1} \frac{1}{x}$
- $f(x) = \cos^{-1} x^2$
- $f(x) = \sin^{-1} \left(\frac{x}{1-x} \right)$
- $f(x) = \sin^{-1} \sqrt{2x}$



Derivative of inverse tangent and inverse cotangent

Activity 5.12

1. We know that $f(x) = \tan^{-1} x$ for $x \in \mathbb{R}$ and $x = \tan y$ for $y \in \left] -\frac{\pi}{2}, \frac{\pi}{2} \right[$ where $y = f(x)$. Use the rule for derivative of composite functions to find the derivative of $\tan^{-1} x$, the inverse of tangent function.
2. We also know that $f(x) = \cot^{-1} x$ for $x \in \mathbb{R}$ and $x = \cot y$ for $y \in]0, \pi[$ where $y = f(x)$. Use the rule for derivative of composite functions to find the derivative of $\cot^{-1} x$, the inverse of cotangent function.

From Activity 5.12,

$$(\tan^{-1} x)' = \frac{1}{1+x^2} \quad \text{and} \quad (\cot^{-1} x)' = \frac{-1}{1+x^2}$$

If u is another function, $(\tan^{-1} u)' = \frac{u'}{1+u^2}$ and $(\cot^{-1} u)' = \frac{-u'}{1+u^2}$

Example 5.34

Find the derivative of $f(x) = (\tan^{-1} 2x)^4$

Solution

$$\begin{aligned} f'(x) &= 4(\tan^{-1} 2x)^3 (\tan^{-1} 2x)' \\ &= 4(\tan^{-1} 2x)^3 \left(\frac{2}{1+4x^2} \right) \\ &= \frac{8(\tan^{-1} 2x)^3}{1+4x^2} \end{aligned}$$

Example 5.35

Find the derivative of $f(x) = 2 \cot^{-1} 3x$

Solution

$$f'(x) = \frac{-2(3x)'}{1+(3x)^2} = \frac{-6}{1+9x^2}$$

Application Activity 5.12

Find the derivative of the following functions:

- $f(x) = \cot^{-1} \sqrt{x}$
- $f(x) = \cos^{-1} \frac{1}{x} - \cot^{-1} x$
- $f(x) = \cot^{-1} \sqrt{x-1}$

Derivative of inverse secant and inverse cosecant**Activity 5.13**

- We know that $f(x) = \sec^{-1} x$ for $x \leq -1$ or $x \geq 1$ and $x = \sec y$ for $y \in [0, \pi], y \neq \frac{\pi}{2}$ where $y = f(x)$. Use the rule for derivative of composite functions to find the derivative of $\sec^{-1} x$, the inverse of secant function.
- We know that $f(x) = \csc^{-1} x$ for $x \leq -1$ or $x \geq 1$ and $x = \csc y$ for $y \in \left[-\frac{\pi}{2}, \frac{\pi}{2}\right], y \neq 0$ where $y = f(x)$. Use the rule for derivative of composite functions to find the derivative of $\csc^{-1} x$ the inverse of cosecant function.

From Activity 5.13,

$$(\sec^{-1} x)' = \frac{1}{x\sqrt{x^2-1}} \quad \text{and} \quad (\csc^{-1} x)' = \frac{-x'}{x\sqrt{x^2-1}}$$

If u is another function, $(\sec^{-1} u)' = \frac{u'}{u\sqrt{u^2-1}}$

and $(\csc^{-1} u)' = \frac{-u'}{u\sqrt{u^2-1}}$

Example 5.36

Find the derivative of $f(x) = \sec^{-1} 2x$

Solution

$$f'(x) = \frac{2}{2x\sqrt{4x^2-1}}$$

Example 5.37

Find the derivative of $f(x) = \csc^{-1} \sqrt{x}$

Solution

$$f'(x) = \frac{-\frac{1}{2\sqrt{x}}}{\sqrt{x}\sqrt{(\sqrt{x})^2 - 1}} = \frac{-1}{2x\sqrt{x-1}}$$

Application Activity 5.13

Find the derivative of the following functions:

1. $f(x) = \sec^{-1}(2x+1)$
2. $f(x) = \tan^{-1} \sqrt{x^2 - 1} + \csc^{-1} x$
3. $f(x) = \sec^{-1} 5x$
4. $f(x) = \csc^{-1}(x^2 + 1), x > 0$

5.3.3. Successive derivatives**Activity 5.14**

Consider the function $f(x) = \cos 2x$. Find:

1. $f'(x)$
2. The derivative of the function obtained in 1.
3. The derivative of the function obtained in 2.
4. The derivative of the function obtained in 3.
5. The derivative of the function obtained in 4.

We have seen that the derivative of a function of x is in general also a function of x . This new function may also be differentiable, in which case the derivative of the first derivative is called the second derivative of the original function.

Similarly, the derivative of the second derivative is called the third derivative and so on.

The successive derivatives of a function f are higher order derivatives of the same function.

We denote higher order derivatives of the same function as follows:

The second derivative is:

$$\frac{d}{dx} \left(\frac{dy}{dx} \right) = \frac{d^2y}{dx^2} = f''(x) = y''$$

The third derivative is:

$$\frac{d}{dx} \left(\frac{d^2y}{dx^2} \right) = \frac{d^3y}{dx^3} = f'''(x) = y'''$$

And the n^{th} derivative is:

$$\frac{d}{dx} \left(\frac{d^{n-1}y}{dx^{n-1}} \right) = \frac{d^ny}{dx^n} = f^{(n)}(x) = y^{(n)}$$

Example 5.38

Find the n^{th} derivative of $y = \sin x$

Solution

$$y' = \cos x = \sin \left(x + \frac{\pi}{2} \right)$$

$$y'' = -\sin x = \sin \left(x + \frac{2\pi}{2} \right)$$

$$y''' = -\cos x = \sin \left(x + \frac{3\pi}{2} \right)$$

⋮

$$y^{(n)} = \sin \left(x + \frac{n\pi}{2} \right)$$

Thus, if $y = \sin x$, $y^{(n)} = \sin \left(x + \frac{n\pi}{2} \right)$

Example 5.39

Find the n^{th} derivative of $y = \cos x$

Solution

$$y' = -\sin x = \cos \left(x + \frac{\pi}{2} \right)$$

$$y'' = -\cos x = \cos\left(x + \frac{2\pi}{2}\right)$$

$$y''' = \sin x = \sin\left(x + \frac{3\pi}{2}\right)$$

:

$$y^{(n)} = \cos\left(x + \frac{n\pi}{2}\right)$$

$$\text{Thus, if } y = \cos x \quad y^{(n)} = \cos\left(x + \frac{n\pi}{2}\right)$$

Application Activity 5.14

1. Find the second derivative of:

- a) $y = \sin 2x \sin 3x$ b) $y = \arctan \sqrt{x}$
 c) $y = \sin^2 x$ d) $y = \tan^2 x$

2. Find the third derivative of:

- a) $y = x \arctan x$ b) $y = \sin 2x \cos 3x$
 c) $y = \frac{\sin 2x}{\sin 3x}$ d) $y = \tan x \tan 2x$

3. Find the n^{th} derivative of:

- a) $y = \sin x + \cos x$ b) $y = \cos 2x$

5.4. Applications

Simple harmonic motion

Activity 5.15



Discuss how differentiation of trigonometric functions is used to find the velocity, acceleration and jerk of a moving object knowing the function representing its position.

In simple harmonic motion (SHM), the displacement $x(t)$ of a particle from its equilibrium position is defined by the equation $x = x_m \cos(\omega t + \phi)$ in which $|x_m|$ is the **amplitude** of the displacement, the quantity $(\omega t + \phi)$ is **phase** of the motion, and ϕ is the **phase constant**. The **angular frequency** ω is related to the period and the frequency of the motion by $\omega = \frac{2\pi}{T} = 2\pi f$.

The motion of an object or weight bobbing freely up down with no resistance on the end of a spring is an example of simple harmonic motion. The motion is periodic and repeats indefinitely, so we represent it using trigonometric functions. If we have the function representing the position, say $S(t)$, then,

- ⊙ The velocity of the object is $v = \frac{ds}{dt}$.
- ⊙ The acceleration of the object is $a = \frac{d^2s}{dt^2}$.
- ⊙ The jerk of the object is $j = \frac{d^3s}{dt^3}$.

Example 5.40

A weight hanging from a spring is stretched down 5 units beyond its rest position and released at time $t=0$ to bob up down. Its position at any later time t is $s=5\cos t$. What are its velocity, acceleration and jerk at time t ?

Solution

Position: $s = 5\cos t$

Velocity (derivative of function representing the position):

$$v = \frac{ds}{dt} = \frac{d}{dt}(5\cos t) = -5\sin t$$

Acceleration (derivative of function representing the velocity):

$$a = \frac{dv}{dt} = \frac{d}{dt}(-5\sin t) = -5\cos t$$

Jerk (derivative of function representing the acceleration):

$$j = \frac{da}{dt} = \frac{d}{dt}(-5\cos t) = 5\sin t$$

Application Activity 5.15

1. A body oscillates with simple harmonic motion according to the equation

$$x = 6\cos\left(3\pi t + \frac{\pi}{3}\right) \quad (x \text{ in metre})$$

At time $t=2s$, what are;

- | | |
|---------------------|------------------------------|
| a) the displacement | b) the velocity |
| c) the acceleration | d) the phase of motion |
| e) the frequency | f) the period of the motion. |

2. An object oscillates with simple harmonic motion along the x -axis. Its displacement from the origin varies in metre with time according to the equation $x = 4 \cos\left(\pi t + \frac{\pi}{4}\right)$ where t is in seconds and the angles

in radians.

- Determine the amplitude, frequency, period of motion and angular frequency.
- Calculate the velocity and acceleration of the object at any time.
- Find displacement, velocity and acceleration at $t = 1$.
- Determine the maximum speed and maximum acceleration

Unit Summary

1. Domain and range of trigonometric functions

Function	Domain	Range
$y = \sin x$	\mathbb{R}	$-1 \leq y \leq 1$
$y = \cos x$	\mathbb{R}	$-1 \leq y \leq 1$
$y = \tan x$	$\mathbb{R} \setminus \left\{\frac{\pi}{2} + k\pi\right\}, k \in \mathbb{Z}$	\mathbb{R}
$y = \csc x$	$\mathbb{R} \setminus \{k\pi\}, k \in \mathbb{Z}$	$y \leq -1$ or $y \geq 1$
$y = \sec x$	$\mathbb{R} \setminus \left\{\frac{\pi}{2} + k\pi\right\}, k \in \mathbb{Z}$	$y \leq -1$ or $y \geq 1$
$y = \cot x$	$\mathbb{R} \setminus \{k\pi\}, k \in \mathbb{Z}$	\mathbb{R}

2. Domain and range of inverses of trigonometric functions

Function	Domain	Range
$y = \sin^{-1} x$	$-1 \leq x \leq 1$	$-\frac{\pi}{2} \leq y \leq \frac{\pi}{2}$
$y = \cos^{-1} x$	$-1 \leq x \leq 1$	$0 \leq y \leq \pi$
$y = \tan^{-1} x$	\mathbb{R}	$-\frac{\pi}{2} < y < \frac{\pi}{2}$
$y = \csc^{-1} x$	$x \leq -1$ or $x \geq 1$	$-\frac{\pi}{2} \leq y \leq \frac{\pi}{2}, y \neq 0$
$y = \sec^{-1} x$	$x \leq -1$ or $x \geq 1$	$0 \leq y \leq \pi, y \neq \frac{\pi}{2}$
$y = \cot^{-1} x$	\mathbb{R}	$0 < y < \pi$

3. A function $f(x)$ is said to be **even** if the following conditions are satisfied

$$\odot \quad \forall x \in \text{Dom}f, -x \in \text{Dom}f \quad \odot \quad f(-x) = f(x)$$

The graph of such a function is **symmetric about the vertical axis**. i.e $x = 0$

4. A function $f(x)$ is said to be **odd** if the following conditions are satisfied:

$$\odot \quad \forall x \in \text{Dom}f, -x \in \text{Dom}f \quad \odot \quad f(-x) = -f(x)$$

The graph of such a function looks the same when rotated through half a revolution about 0. This is called **rotational symmetry**.

5. A function f is called **periodic** if there is a positive number P such that $f(x+P) = f(x)$ whenever x and $x+P$ lie in the domain of f . We call P a **period** of the function.

6. When removing indetermination $\frac{0}{0}$ in the calculation of limit of a trigonometric function, we may allow for $\lim_{x \rightarrow 0} \frac{\sin x}{x} = 1$.

7. Derivative of trigonometric functions and their inverses

$$(\sin u)' = u' \cos u, \quad (\cos u)' = -u' \sin u$$

$$(\tan u)' = \frac{u'}{\cos^2 u}$$

$$= u' \sec^2 u$$

$$= u'(1 + \tan^2 u)$$

$$(\cot u)' = \frac{-u'}{\sin^2 u}$$

$$= -u' \csc^2 u$$

$$= -u'(1 + \cot^2 u)$$

$$(\sec u)' = u' \sec u \tan u, \quad (\csc u)' = -u' \csc u \cot u$$

$$(\sin^{-1} u)' = \frac{u'}{\sqrt{1-u^2}}, \quad (\cos^{-1} u)' = \frac{-u'}{\sqrt{1-u^2}}$$

$$(\tan^{-1} u)' = \frac{u'}{1+u^2}, \quad (\cot^{-1} u)' = \frac{-u'}{1+u^2}$$

$$(\sec^{-1} u)' = \frac{u'}{u\sqrt{u^2-1}}, \quad (\csc^{-1} u)' = \frac{-u'}{u\sqrt{u^2-1}}$$

End of Unit Assessment

1. State whether each of the following functions is periodic. If the function is periodic, give its fundamental period.

a) $f(x) = \sin 3x$

b) $f(x) = 1 + \tan x$

c) $f(x) = \cos(x+1)$

d) $f(x) = \cos(x^2)$

e) $f(x) = \cos^2 x$

f) $f(x) = x + \sin x$

2. Study the parity of the following functions and state whether it is either even or odd or otherwise.

a) $f(x) = \cos x + \sin x$

b) $f(x) = \frac{\sin x}{x^2 + 1}$

c) $f(x) = \frac{x + \sin x}{x^2}$

3. Find the limit of the following functions:

a) $\lim_{x \rightarrow \frac{\pi}{4}} (1 + \cot x)$

b) $\lim_{x \rightarrow 0} \frac{1 - \cos^3 x}{\sin^2 x}$

c) $\lim_{x \rightarrow 0} \frac{1 + \sin x}{1 + \cos x}$

$$\begin{array}{lll}
 \text{d) } \lim_{x \rightarrow \frac{\pi}{4}} \frac{\csc^2 x - 2}{\cot x - 1} & \text{e) } \lim_{x \rightarrow 0} \frac{\sin 7x}{x} & \text{f) } \lim_{x \rightarrow 0} \frac{\sin 8x}{\sin 5x} \\
 \text{g) } \lim_{x \rightarrow 0} \frac{\sin^2 \frac{x}{2}}{4x^2} & \text{h) } \lim_{x \rightarrow 0} \frac{\sin^2(-11x)}{\tan 9x} & \\
 \text{i) } \lim_{x \rightarrow 0} \frac{\sin 3x \sin 5x}{7x^2} & \text{j) } \lim_{x \rightarrow 3} \frac{\sin(x^2 - 3x)}{x^2 - 9} & \\
 \text{k) } \lim_{x \rightarrow 1} \frac{(x^2 - x)\sin(x-1)}{x^2 - 2x + 1} & \text{l) } \lim_{x \rightarrow a} \frac{\sin x - \sin a}{x - a} & \\
 \text{m) } \lim_{x \rightarrow 0} \frac{\sin(a+x) + \sin(a-x) - 2\sin a}{x \sin x} & & \\
 \text{n) } \lim_{x \rightarrow 0} \frac{\sec x - 1}{x^2} & \text{o) } \lim_{x \rightarrow 0} \frac{3\sin x - \sin 3x}{x^3} & \\
 \text{p) } \lim_{x \rightarrow 0} x^2 \left(\sin \frac{1}{x} \right) \csc x & \text{q) } \lim_{x \rightarrow 0} \frac{\sec 9x - \sec 7x}{\sec 5x - \sec 3x} & \\
 \text{r) } \lim_{x \rightarrow \frac{\pi}{2}} \frac{\sec x - \tan x}{\frac{\pi}{2} - x} & \text{s) } \lim_{x \rightarrow 0} \frac{x^2 + \sin 3x}{2x + \tan 2x} & \\
 \text{t) } \lim_{\theta \rightarrow \frac{\pi}{2}} \frac{\sec \theta - \tan \theta}{\frac{\pi}{2} - \theta} & \text{u) } \lim_{x \rightarrow 1} \frac{1 + \cos \pi x}{(1-x)^2} & \\
 \text{v) } \lim_{x \rightarrow \pi} \frac{\sqrt{5 + \cos x} - 2}{\pi - x} & \text{w) } \lim_{x \rightarrow \frac{\pi}{4}} \frac{\sqrt{2} - \cos x - \sin x}{(4x - x)^2} &
 \end{array}$$

4. Find the first derivative of the following functions:

$$\begin{array}{ll}
 \text{a) } f(x) = 3 \sec x - 10 \cot x & \text{b) } f(x) = 3x^{-4} - x^2 \tan x \\
 \text{c) } y = 5 \sin x \cos x + 4 \csc x & \text{d) } P(t) = \frac{\sin t}{3 - 2 \cos t} \\
 \text{e) } y = 4 \cos(6x^2 + 5) & \text{f) } y = 3 \sin^3(2x^4 + 1) \\
 \text{g) } y = (x - \cos^2 x)^4 & \text{h) } y = \frac{2x + 3}{\sin 4x}
 \end{array}$$

$$\text{i) } y = x\sqrt{1-x^2} + \cos^{-1} x \quad \text{j) } y = \sec^{-1} \frac{1}{x}$$

$$\text{k) } y = \csc^{-1} \frac{x}{2} \quad \text{l) } y = \sqrt{x^2-1} - \sec^{-1} x$$

$$\text{m) } x \sin^{-1} x + \sqrt{1-x^2}$$

5. Suppose that the amount of money in a bank account is given by $P(t) = 500 + 100 \cos t - 150 \sin t$ where t is in years. During the first 10 years in which the account is open, when is the amount of money in the account increasing?
6. The equation $s = 2 - 2 \sin t$ gives the position of a body moving on a coordinate line (s in metres, t in seconds). Find the body's velocity, speed, acceleration, and jerk at time $t = \frac{\pi}{4}$ sec
7. A weight is attached to a spring and reaches its equilibrium position ($x=0$). It is then set in motion resulting in a displacement of $x = 10 \cos t$. Find the spring's velocity when $t = 0$, $t = \frac{\pi}{3}$ and $t = \frac{3\pi}{4}$
8. Assume that a particle's position on the x -axis is given by $x = 3 \cos t + 4 \sin t$, where x is measured in metres and t is measured in seconds. Find the particle's velocity when $t = 0$, $t = \frac{\pi}{2}$ and $t = \pi$
9. Suppose that a piston is moving straight up and down and that its position at time t sec is $s = A \cos(2\pi bt)$ with A and b positive. The value of A is the amplitude of the motion, and b is the frequency (number of times the piston moves up and down each second). What effect does doubling the frequency have on the piston's velocity, acceleration and jerk? (Once you find out, you will know why some machinery breaks when you run it too fast).

10. Evaluate

a) $\lim_{x \rightarrow 2} \sin^{-1} \frac{\sqrt{x^2 - 1}}{x}$

c) $\lim_{x \rightarrow \frac{\pi}{3}} \tan^{-1}(\tan 2x)$

e) $\lim_{x \rightarrow 0} \frac{2 \tan^{-1} 3x^2}{7x^2}$

g) $\lim_{x \rightarrow 0^+} \frac{(\tan^{-1} \sqrt{x})^2}{x\sqrt{x+1}}$

b) $\lim_{x \rightarrow 0} \tan^{-1}(x-1)$

d) $\lim_{x \rightarrow -1} \sec^{-1} \frac{x-1}{\sqrt{x^2+1}}$

f) $\lim_{x \rightarrow 0} \frac{\tan^{-1} x^2}{x \sin^{-1} x}$

h) $\lim_{x \rightarrow 0} \frac{\sin^{-1} x^2}{(\sin^{-1} x)^2}$

Unit 6

Vector Space of Real Numbers

Introductory activity

A vector space is a collection of objects called vectors, which may be added together and multiplied by numbers, called scalars in this context.

To put it really simple, vectors are basically all about directions and magnitudes. These are critical in basically all situations.

In physics, vectors are often used to describe forces, and forces add as vectors do.

- a) Discuss the properties of addition of vectors.
- b) What happens when a vector is multiplied by a scalar (real number)?
- c) Give at least 3 examples of vectors in real life.

Objectives

By the end of this unit, a student will be able to:

- ⊙ Define and apply different operations on vectors.
- ⊙ Show that a vector is a sub-vector space.
- ⊙ Define linear combination of vectors.
- ⊙ Find the norm of a vector.
- ⊙ Calculate the scalar and vector product of two vectors.
- ⊙ Calculate the angle between two vectors.
- ⊙ Apply and transfer the skills of vectors to other area of knowledge.

6.1. Vector space \mathbb{R}^3

6.1.1. Position of points and vectors in 3 dimensions

In plane, the position of a point is determined by two numbers x, y obtained with reference to two straight lines (x -axis and y -axis respectively) in the plane intersecting at right angle. The position of point in space is, however, determined by three numbers x, y, z obtained with reference to three straight lines (x -axis, y -axis and z -axis respectively) intersecting at right angles.

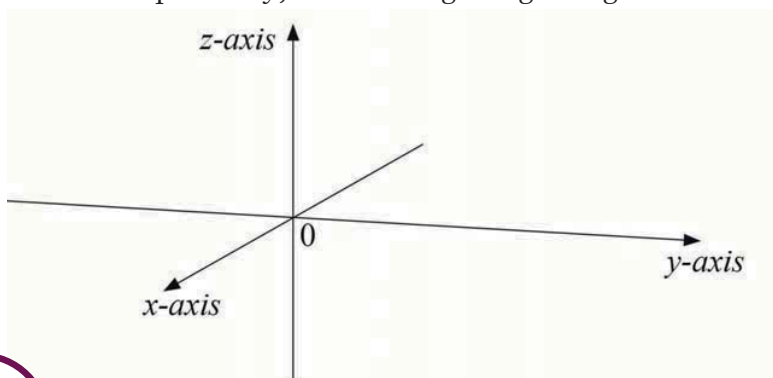

Activity 6.1

1. In space, from the point $A(3,2,2)$, along x -axis measure $OM = 3$ units, measure $MN = 2$ units parallel to y -axis then measure $NP = 2$ units parallel to z -axis. P is the point of coordinate $(3,2,2)$ in space.
2. In the same space, present the point $B(1,3,2)$ and then join points A and B with arrow from A to B .
3. Find $B - A$

A vector is a directed line segment. That is to say, a vector has a given length and a given direction.

The vector joining point A and point B is denoted by \overrightarrow{AB} and its components are found by subtracting the coordinates of point A from the coordinates of point B . For example, the components of vector \overrightarrow{AB} defined by two points $A(a_1, a_2, a_3)$ and $B(b_1, b_2, b_3)$

are given by $(b_1, b_2, b_3) - (a_1, a_2, a_3)$. Then a vector in space may be described by ordered triple of coordinates (a, b, c) . The point A is called the **initial point** or **tail** of \overline{AB} and B is called the **terminal point** or **tip**.

If the initial point is fixed, the vector is called a **bound** or **localised** vector. All other vectors are called **free** vectors.

The set of vectors of space is denoted by V . A vector is entirely determined by only one of its couples or by only one of its representatives.

Let the point O be fixed, as common origin of all representatives. This point O will be called the origin of the space E and define a bijection of the set of points of the space E on the set V of vectors of space.

The set of vectors of space with origin O is denoted by E_0 and $E_0 = \{\overline{Oa} : a \in E\}$.

The vector \overline{OP} joining the origin, O , to the point P is called the **position vector** of P with respect to O , or simply the position vector of P .

We sometimes denote the position vector of P by \vec{P} . That is $\overline{OP} = \vec{P}$. The **zero vector** is $(0, 0, 0)$ denoted by $\vec{0}$.

Example 6.1

Find vectors \overline{AB} and \overline{BA} given that $A(1, 2, 3)$ and $B(2, 1, 0)$.

Solution

$$\overline{AB} = (1, -1, -3) \quad \overline{BA} = (-1, 1, 3)$$

Parallel vectors

Two vectors are parallel if and only if

- they have the same direction, or
- they have opposite directions.

Thus, two vectors are parallel if and only if one can be expressed

as a scalar multiple of the other. i.e, if \vec{u} is parallel to \vec{v} , then $\vec{u} = r\vec{v}$ or $\vec{v} = s\vec{u}$ for real numbers r and s . In this case, we write $\vec{u} \parallel \vec{v}$.

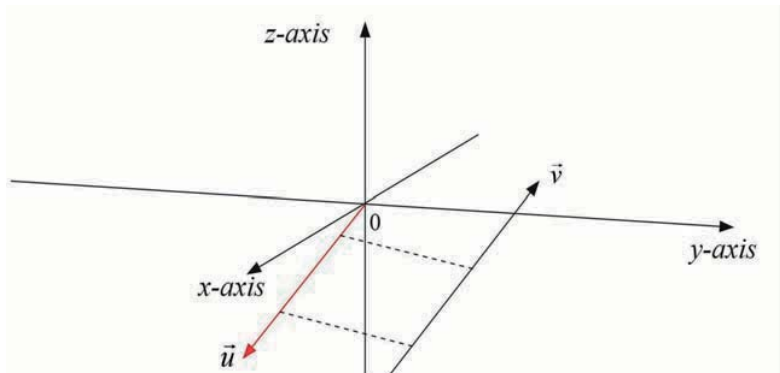

Equal vectors

Two vectors are equal if they have the same length and the same direction. If \vec{u} is equal to \vec{v} , we write $\vec{u} = \vec{v}$.

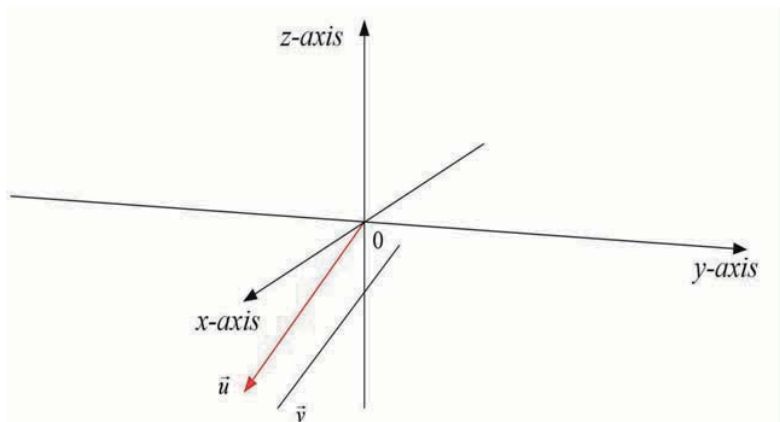

Opposite vectors

Two vectors are opposite if the coordinates of one vector are additive inverse of the coordinates of the other. That is, if \vec{u} and \vec{v} are opposite then $\vec{u} = -\vec{v}$.

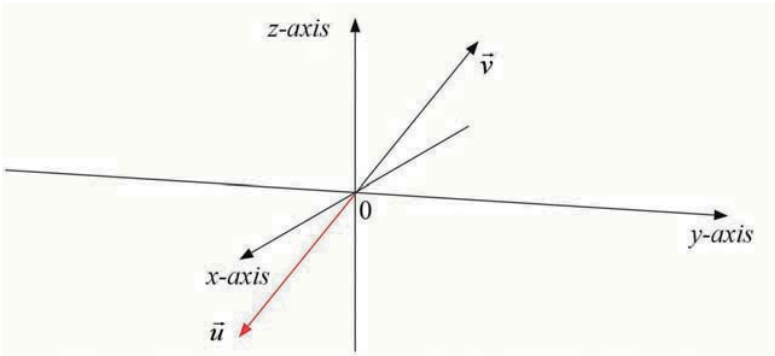

Operations on vectors

Sum of two vectors

Two non parallel (or opposite) vectors of the same origin (means that their tails are together) determine one and only one plane in space.

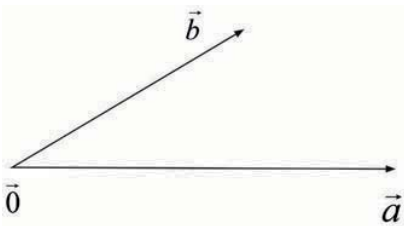

The addition of vectors of E_0 is the application defined by $E_0 \times E_0 \rightarrow E_0$

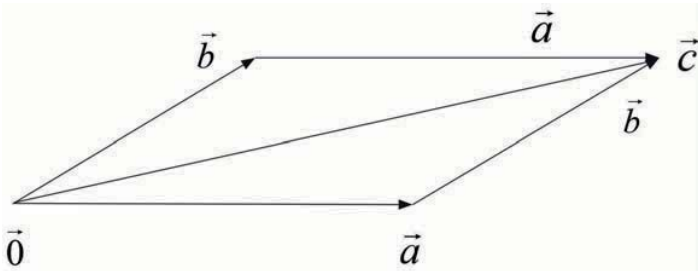

\vec{c} is then the diagonal of the parallelogram built from \vec{a} and \vec{b} . Thus, $\vec{a} + \vec{b} = \vec{c}$ if $\vec{a} = (a_1, a_2, a_3)$, $\vec{b} = (b_1, b_2, b_3)$, $\vec{a} + \vec{b} = (a_1 + b_1, a_2 + b_2, a_3 + b_3)$

If the tails are not together, and the tail of \vec{b} is joined to the tip of \vec{a} , then the sum $\vec{a} + \vec{b}$ is the vector joining the tail of \vec{a} and the tip of \vec{b} .

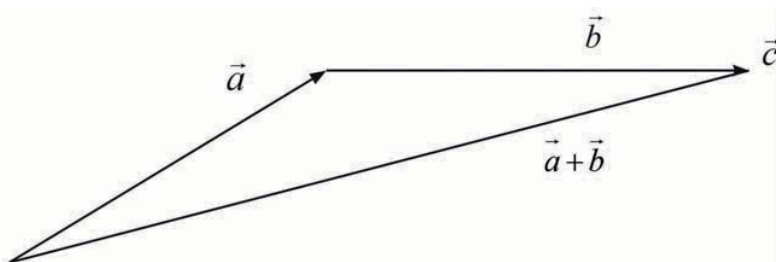

Particular case

1. If two vectors are **parallel**, to find the sum; the second is newly replaced by equal vector but having its origin at the end of the first one.



2. If two vectors are **opposite**, their sum is zero vector. The opposite of the vector \vec{a} is denoted by $-\vec{a}$.

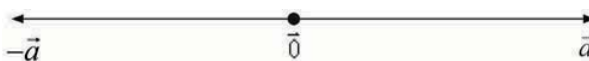

From the addition of vectors, we define the subtraction of vector as $\vec{a} - \vec{b} = \vec{a} + (-\vec{b})$ if $\vec{a} = (a_1, a_2, a_3)$, $\vec{b} = (b_1, b_2, b_3)$, $\vec{a} - \vec{b} = (a_1 - b_1, a_2 - b_2, a_3 - b_3)$

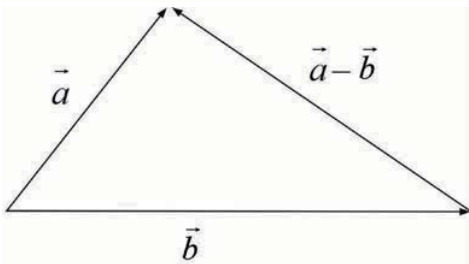
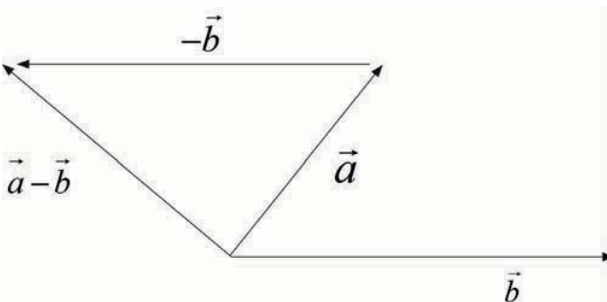

Properties

1. The addition defined above verifies the closure property in E_0 .

$$\text{That is, } \forall \vec{a}, \vec{b} \in E_0, \vec{a} + \vec{b} \in E_0$$

2. It is commutative. That is, $\forall \vec{a}, \vec{b} \in E_0, \vec{a} + \vec{b} = \vec{b} + \vec{a}$

3. It is associative. That is, $\forall \vec{a}, \vec{b}, \vec{c} \in E_0, (\vec{a} + \vec{b}) + \vec{c} = \vec{a} + (\vec{b} + \vec{c})$

4. The identity element is zero vector. That is,

$$\forall \vec{a} \in E_0, \vec{0} \in E_0 : \vec{a} + \vec{0} = \vec{a} = \vec{0} + \vec{a}$$

5. The symmetric element is the opposite of a vector.

$$\text{That is, } \forall \vec{a} \in E_0, \exists (-\vec{a}) \in E_0 : \vec{a} + (-\vec{a}) = \vec{0}$$

Scalar multiplication

The definition of scalar multiplication in space E_0 is the same as in plane.

The product of a vector \vec{a} with a real number α is defined by $\alpha(\vec{a})$



Note that if the real number α is positive, the resulting vector has the same direction as \vec{a} and if it is negative the resulting vector has the opposite direction to that of \vec{a} .

$$\text{If } \vec{a} = (a_1, a_2, a_3), \lambda \vec{a} = (\lambda a_1, \lambda a_2, \lambda a_3)$$

Properties

⊙ Associative, $\forall \vec{a} \in E_0, r, s \in \mathbb{R}, (rs)\vec{a} = r(s\vec{a})$

⊙ Distributive with respect to addition of vectors,
 $\forall \vec{a}, \vec{b} \in E_0, r \in \mathbb{R}, r(\vec{a} + \vec{b}) = r\vec{a} + r\vec{b}$

⊙ Distributive with respect to addition of reals,
 $\forall \vec{a} \in E_0, r, s \in \mathbb{R}, (r+s)\vec{a} = r\vec{a} + s\vec{a}$

⊙ 1 is the identity for scalar multiplication, $\forall \vec{a} \in E_0, 1\vec{a} = \vec{a}$

Application Activity 6.1

Given points $A(6,0,-3)$ and $B(3,-3,0)$ and vectors $\vec{u} = (3,4,6), \vec{v} = (1,1,1)$. Find;

1. Vector \overrightarrow{AB}
2. Sum $\overrightarrow{AB} + \vec{u} - \vec{v}$
3. Sum $2\overrightarrow{AB} - 3\vec{u} + \vec{v}$
4. Sum $4\vec{u} - \overrightarrow{AB} + 2\vec{v}$

6.1.2. Sub-vector space

Activity 6.2



Consider $V = \{(0, x, 3x), x \in \mathbb{R}\}$

1. What would be the value of x so that $(0,0,0) \in V$?
2. Let $\vec{u} = (0, a, 3a), \vec{v} = (0, b, 3b)$. Show that for any real number α, β satisfy, $\alpha\vec{u} + \beta\vec{v} \in V$.

A subset V of \mathbb{R}^n is called a **sub-vector space**, or just a **sub-space**, of \mathbb{R}^n if it has the following properties:

- ⊙ The 0-vector belongs to V ,
- ⊙ V is closed under vector addition, i.e if $\vec{u}, \vec{v} \in V$ then $\vec{u} + \vec{v} \in V$.
- ⊙ V is closed under scalar multiplication, i.e if $\alpha \in \mathbb{R}, \vec{u} \in V$, $\alpha\vec{u} \in V$.

Generally,

If $(\mathbb{R}, F, +)$ is a sub-space of $(\mathbb{R}, E, +)$, then

- ⊙ $F \subset E$
- ⊙ $\vec{0} \in F$
- ⊙ $\vec{u}, \vec{v} \in F, \alpha, \beta \in \mathbb{R}; \alpha\vec{u} + \beta\vec{v} \in F$

Example 6.2

Consider $A = \{(x, 0, 2x), x \in \mathbb{R}\}$, we show that $(\mathbb{R}, A, +)$ is a sub-vector space of \mathbb{R}^3 :

- ⊙ $A \subset \mathbb{R}^3$
- ⊙ If we take $x = 0$, we see that $(0, 0, 0) \in A$
- ⊙ Consider $\vec{k} = (k, 0, 2k), \vec{l} = (l, 0, 2l) \in A, \alpha, \beta \in \mathbb{R}$

$$\begin{aligned}
 \alpha\vec{k} + \beta\vec{i} &= \alpha(k, 0, 2k) + \beta(t, 0, 2t) \\
 &= (\alpha k, 0, 2\alpha k) + (\beta t, 0, 2\beta t) \\
 &= (\alpha k + \beta t, 0, 2\alpha k + 2\beta t) \\
 &= (\alpha k + \beta t, 0, 2(\alpha k + \beta t)) \\
 &= (y, 0, 2y) \quad \text{for } y = \alpha k + \beta t
 \end{aligned}$$

Then $\alpha\vec{k} + \beta\vec{i} \in A$; therefore, A is a sub-space of \mathbb{R}^3 .

Properties

1. If $(\mathbb{R}, F, +)$ and $(\mathbb{R}, G, +)$ are sub-vector spaces of $(\mathbb{R}, E, +)$ then $(\mathbb{R}, F \cap G, +)$ is also a sub-vector space of $(\mathbb{R}, E, +)$.



Notice

- ⊙ Each vector space has two sub-vector spaces called **trivial sub-vector spaces**. Those are the vector space themselves and 0-vector.
- ⊙ Trivial sub-vector spaces are also called **improper sub-vector spaces**.
- ⊙ Other sub-vector spaces are called **proper sub-vector spaces**.

2. If $(\mathbb{R}, F, +)$ is a sub-vector space of $(\mathbb{R}, E, +)$, then

$$\dim F \leq \dim E$$



Notice

If F is a proper part of $(\mathbb{R}, E, +)$ (means that $(\mathbb{R}, F, +)$ is a proper sub-vector space of $(\mathbb{R}, E, +)$), then $\dim F < \dim E$.

Sum of two sub-vector spaces

If F and G are two sub-vector spaces of E then the sum of F and G is also a sub-vector space of E . It is denoted as $F + G = \{x + y, x \in F, y \in G\}$

Theorem 6.1

- ⊙ W_1 and W_2 are sub-spaces of V , then $W_1 \cup W_2$ is a sub-space $\Leftrightarrow W_1 \subseteq W_2$ or $W_2 \subseteq W_1$.
- ⊙ W_1 and W_2 are sub-space of V , then $W_1 + W_2$ is the smallest sub-space that contains both W_1 and W_2 .

Property

If $(\mathbb{R}, F, +)$ and $(\mathbb{R}, G, +)$ are two sub-vector spaces of $(\mathbb{R}, E, +)$ we have;

$$\dim(F + G) = \dim(F) + \dim(G) - \dim(F \cap G).$$

Example 6.3

Consider $F = \{(x, 0, z), x, z \in \mathbb{R}\}$ and $G = \{(x, y, 0), x, y \in \mathbb{R}\}$

For F:

$$\left. \begin{aligned} (x, 0, z) &= (x, 0, 0) + (0, 0, z) \\ &= x(1, 0, 0) + z(0, 0, 1) \end{aligned} \right\} \Rightarrow \dim(F) = 2$$

For G:

$$\left. \begin{aligned} (x, y, 0) &= (x, 0, 0) + (0, y, 0) \\ &= x(1, 0, 0) + y(0, 1, 0) \end{aligned} \right\} \Rightarrow \dim(G) = 2$$

$$F + G = \{(2x, y, z), x, y, z \in \mathbb{R}\}$$

$$\left. \begin{aligned} (2x, y, z) &= (2x, 0, 0) + (0, y, 0) + (0, 0, z) \\ &= x(2, 0, 0) + y(0, 1, 0) + z(0, 0, 1) \end{aligned} \right\} \Rightarrow \dim(F + G) = 3$$

$$F \cap G = \{(x, 0, 0), x \in \mathbb{R}\}$$

$$\left. \begin{aligned} (x, 0, 0) &= (x, 0, 0) \\ &= x(1, 0, 0) \end{aligned} \right\} \Rightarrow \dim(F \cap G) = 1$$

Then $\dim(F + G) = 3$

$$\begin{aligned} &= \dim(F) + \dim(G) - \dim(F \cap G) \\ &= 2 + 2 - 1 \\ &= 3 \end{aligned}$$

Remark

If $\dim(F \cap G) = 0$, then $\dim(F + G) = \dim(F) + \dim(G)$. In this case, F and G are said to be **complementary** and the sum $F + G$ is said to be a **direct sum**; and it is denoted by $F \oplus G$.

Otherwise, F and G are said to be **supplementary**.

Example 6.4

$F^n = W_1 \oplus W_2$, where

$$W_1 = \{(a_1, \dots, a_{n-1}, 0) \in F^n : a_n = 0\}$$

$$W_2 = \{(0, \dots, 0, a_n) \in F^n : a_1 = a_2 = \dots = a_{n-1} = 0\}$$

Example 6.5

$P(F) = W_1 \oplus W_2$, where

$$W_1 = \{f(x) = a_{2n+1}x^{2n+1} + \dots + a_1x : a_0 = a_2 = a_4 = \dots = 0\}$$

$$W_2 = \{g(x) = b_{2m}x^{2m} + \dots + b_0 : b_1 = b_3 = b_5 = \dots = 0\}$$

Theorem 6.2

The vector space V is the direct sum of its sub-spaces W_1 and W_2 (i.e., $V = W_1 \oplus W_2$) if and only if $V = W_1 + W_2$ and $W_1 \cap W_2 = \{0\}$

Let W_1 and W_2 be two sub-spaces of a vector space V over F , and then $V = W_1 \oplus W_2 \Leftrightarrow \forall x \in V, \exists! x_1 \in W_1, \exists! x_2 \in W_2$ such that $x = x_1 + x_2$.

Also, if we suppose $x = x_1 + x_2 = y_1 + y_2$, $\begin{cases} x_1 \in W_1, \\ y_1 \in W_1, \end{cases} \begin{cases} x_2 \in W_2, \\ y_2 \in W_2, \end{cases}$
 $x_1 - y_1 = y_2 - x_2$

$$x_1 - y_1 \in W_1, y_2 - x_2 \in W_2, \therefore x_1 - y_1 = y_2 - x_2 \in W_1 \cap W_2 = \{0\} \Rightarrow$$

$$x_1 = y_1, x_2 = y_2.$$

Example 6.6

Let $W_1, W_2,$ and W_3 denote the x -, the y -, and the z -axis, respectively.

Then, $\mathbb{R}^3 = W_1 \oplus W_2 \oplus W_3$, $W_i \cap \left(\sum_{j \neq i} W_j \right) = \{0\}$.

$$\forall (a, b, c) \in \mathbb{R}^3, (a, b, c) = (a, 0, 0) + (0, b, 0) + (0, 0, c),$$

Where $(a, 0, 0) \in W_1, (0, b, 0) \in W_2, (0, 0, c) \in W_3$.

Therefore, \mathbb{R}^3 is uniquely represented as a direct sum of $W_1, W_2,$ and W_3 .

Example 6.7

Let $U = \{(a, b, 0) : a, b \in \mathbb{R}\}$ be the xy -plane and let $W = \{(0, 0, c) : c \in \mathbb{R}\}$ be the z -axis. Now, any vector $(a, b, c) \in \mathbb{R}^3$ can be written as the sum of a vector in U and a vector in W in one and only one way: $(a, b, c) = (a, b, 0) + (0, 0, c)$. Accordingly, \mathbb{R}^3 is a direct sum of U and W , that is, $\mathbb{R}^3 = U \oplus W$.

Application Activity 6.2

Show that the following are or are not sub-vector spaces of \mathbb{R}^3

1. $F = \{(y, z, 0), y, z \in \mathbb{R}\}$
2. $G = \{(2x, 3y, 0), x, y \in \mathbb{R}\}$
3. $H = \{(x, 0, z), x, z \in \mathbb{R}\}$
4. $K = \{(x, xz + 1, 0), x, z \in \mathbb{R}\}$

6.1.3. Linear combination

Activity 6.3



Find the value of a and b such that

$$a(1, -1, 0) + b(1, 3, -1) = (5, 3, -2)$$

The vector \vec{u} is called a linear combination of the vectors $\vec{u}_1, \vec{u}_2, \vec{u}_3$ provided that there exists scalars c_1, c_2, c_3 such that $\vec{u} = c_1\vec{u}_1 + c_2\vec{u}_2 + c_3\vec{u}_3$

Let $S = \{\vec{u}_1, \vec{u}_2, \vec{u}_3\}$ be a set of vectors in the vector space V . The set of all linear combinations of $\vec{u}_1, \vec{u}_2, \vec{u}_3$ is called the **span** of the set S , denoted by $span(S)$ or $span(\vec{u}_1, \vec{u}_2, \vec{u}_3)$.

The set $S = \{\vec{u}_1, \vec{u}_2, \vec{u}_3\}$ of vectors in the vector space V is a **spanning set** for V (or a **generating set** for V) provided that every vector in V is a linear combination of the vectors in S .

The set of vectors $S = \{\vec{u}_1, \vec{u}_2, \vec{u}_3\}$ of a vector space V is said to be **linearly independent** provided that the equation $c_1\vec{u}_1 + c_2\vec{u}_2 + c_3\vec{u}_3 = \vec{0}$ has only the trivial solution $c_1 = c_2 = c_3 = 0$.

A set of vectors is called **linearly dependent** if it is not linearly independent. Or if $c_1\vec{u}_1 + c_2\vec{u}_2 + c_3\vec{u}_3 = \vec{0}$ for $(c_1, c_2, c_3) \neq (0, 0, 0)$.

Example 6.8

Show that the vectors $\vec{u} = (1, -1, 0)$, $\vec{v} = (1, 3, -1)$, and $\vec{w} = (5, 3, -2)$ are linearly dependent.

Solution

Since $3\vec{u} + 2\vec{v} - \vec{w} = \vec{0}$ or we can solve for $c_1(1, -1, 0) + c_2(1, 3, -1) + c_3(5, 3, -2) = \vec{0}$ which gives

$$\begin{cases} c_1 + c_2 + 5c_3 = 0(1) \\ -c_1 + 3c_2 + 3c_3 = 0(2) \\ -c_2 - 2c_3 = 0(3) \end{cases}$$

From (3), $c_2 = -2c_3$ (4). (4) in (1) and (2) gives

$$c_1 + 3c_3 = 0 \Rightarrow c_1 = -3c_3 \text{ and then } \begin{cases} c_1 = -3c_3 \\ c_2 = -2c_3 \end{cases} \text{ this system has many}$$

solutions (not only trivial solution).

One of them, which is not trivial, is $c_1 = 3, c_2 = 2$ and $c_3 = -1$. Therefore, the given three vectors are linearly dependent.

Example 6.9

Show that the vectors $\vec{u} = (1, 0, 0)$, $\vec{v} = (0, 1, 0)$ and $\vec{w} = (0, 0, 1)$ are linearly independent.

Solution

$$\begin{cases} c_1 + 0c_2 + 0c_3 = 0(1) \\ 0c_1 + c_2 + 0c_3 = 0(2) \\ 0c_1 + 0c_2 + c_3 = 0(3) \end{cases}$$

This system has only trivial solution $c_1 = 0, c_2 = 0$, and $c_3 = 0$. Therefore, the given three vectors are linearly independent.

Theorem 6.3

The three vectors $\vec{u}_1, \vec{u}_2, \vec{u}_3$ in \mathbb{R}^3 are linearly independent if and only if the 3×3 matrix $A = \begin{bmatrix} \vec{u}_1 & \vec{u}_2 & \vec{u}_3 \end{bmatrix}$ with the vectors as columns has non-zero determinant.

Example 6.10

Define a determinant of a (3×3) matrix. Show that the vectors $\vec{u} = (1, 2, 0)$, $\vec{v} = (0, -1, 3)$, $\vec{w} = (-1, 0, 2)$ are linearly independent.

Solution

The three vectors are linearly independent if

$$\begin{vmatrix} 1 & 0 & -1 \\ 2 & -1 & 0 \\ 0 & 3 & 2 \end{vmatrix} \neq 0$$

$$\begin{vmatrix} 1 & 0 & -1 \\ 2 & -1 & 0 \\ 0 & 3 & 2 \end{vmatrix} = 1 \begin{vmatrix} -1 & 0 \\ 3 & 2 \end{vmatrix} - 0 \begin{vmatrix} 2 & 0 \\ 0 & 2 \end{vmatrix} - 1 \begin{vmatrix} 2 & -1 \\ 0 & 3 \end{vmatrix}$$

$$= -2 - 0 - 6 = -8$$

Thus, the given vectors are linearly independent.

Theorem 6.4

The three vectors $\vec{u}_1, \vec{u}_2, \vec{u}_3$ in \mathbb{R}^3 are linearly dependent if and only if the 3×3 matrix $A = \begin{bmatrix} \vec{u}_1 & \vec{u}_2 & \vec{u}_3 \end{bmatrix}$ with the vectors as columns has zero determinant.

Example 6.11

Show that the vectors $\vec{u} = (1, 2, 3)$, $\vec{v} = (1, -1, -2)$, $\vec{w} = (2, 1, 1)$ are linearly dependent.

Solution

The three vectors are linearly dependent if

$$\begin{vmatrix} 1 & 1 & 2 \\ 2 & -1 & 1 \\ 3 & -2 & 1 \end{vmatrix} = 0 \qquad \begin{vmatrix} 1 & 1 & 2 \\ 2 & -1 & 1 \\ 3 & -2 & 1 \end{vmatrix} = 1 \begin{vmatrix} -1 & 1 \\ -2 & 1 \end{vmatrix} - 1 \begin{vmatrix} 2 & 1 \\ 3 & 1 \end{vmatrix} + 2 \begin{vmatrix} 2 & -1 \\ 3 & -2 \end{vmatrix}$$

$$= 1 + 1 - 2 = 0$$

Thus, the given vectors are linearly dependent.

Theorem 6.5

A finite set S of vectors in a vector space V is called a **basis for V** provided that;

- ⊙ The vectors in S are linearly independent,
- ⊙ The vector in S span V (or S is a generating set of V).

Example 6.12

The set of standard unit vectors in \mathbb{R}^3 , $\{(1,0,0), (0,1,0), (0,0,1)\}$ is the **standard** (or **usual** or **canonical**) **basis** for \mathbb{R}^3 .

Theorem 6.6

Let $S = \{\vec{u}_1, \vec{u}_2, \vec{u}_3\}$ be a basis for the vector space V . Then any set of more than three vectors in V is linearly dependent.

Theorem 6.7

Any two bases of a vector space consist of the same number of vectors.

Theorem 6.8

A vector space V is called **finite dimensional** if it has a basis consisting of a finite number of vectors. The unique number of vectors in each basis for V is called the **dimension** of V and is denoted by $\dim(V)$. A vector space that is not finite dimensional is called **infinite dimensional**.

Example 6.13

Consider a vector space E of polynomials of degree 3 of x . Any element of E is of the form $P(x) = a_0 + a_1x + a_2x^2 + a_3x^3$, $a_i \in \mathbb{R}$.

We verify that $(1, x, x^2, x^3)$ is a basis of E because

$$a_0 + a_1x + a_2x^2 + a_3x^3 = 0$$

$\Rightarrow a_0 = a_1 = a_2 = a_3 = 0$. Moreover, $(1, x, x^2, x^3)$ is a generating set of E . This set has 3+1 elements, then $\dim(E) = 4$

Example 6.14

We have seen that the set $\{\vec{e}_1 = (1,0,0), \vec{e}_2 = (0,1,0), \vec{e}_3 = (0,0,1)\}$ is the basis for \mathbb{R}^3 . Thus \mathbb{R}^3 has dimension 3.

Application Activity 6.3

1. Write the vector $\vec{v} = (1, -2, 5)$ as a linear combination of the vectors $\vec{e}_1 = (1, 1, 1)$, $\vec{e}_2 = (1, 2, 3)$ and $\vec{e}_3 = (2, -1, 1)$.
2. Show that the vectors $\vec{u} = (1, 2, 3)$, $\vec{v} = (0, 1, 2)$ and $\vec{w} = (0, 0, 1)$ generate \mathbb{R}^3 .

3. Consider the vectors $\vec{u} = (1, -3, 2)$, $\vec{v} = (2, -1, 1)$ of \mathbb{R}^3
- a) If $\vec{w} = (1, 7, -4)$, is $\{\vec{u}, \vec{v}, \vec{w}\}$ a basis of \mathbb{R}^3 ?
- b) For what value of real number k , the vector $(1, k, 5)$ is a linear combination of \vec{u} and \vec{v} ?

Coordinate vector



Activity 6.4

Consider the vector $\vec{u} = (3, 1, 4)$ and the basis $\{(1, 2, 0), (0, -1, 3), (-1, 0, 2)\}$. Find the value of a, b, c such that $(3, 1, 4) = a(1, 2, 0) + b(0, -1, 3) + c(-1, 0, 2)$

Suppose that $S = \{\vec{v}_1, \vec{v}_2, \vec{v}_3\}$ is a basis for a vector space V and that \vec{u} is any vector from V . As \vec{u} is a vector in V , it can be expressed as a linear combination of the vectors from S as follows:

$$\vec{u} = c_1\vec{v}_1 + c_2\vec{v}_2 + c_3\vec{v}_3$$

The scalars c_1, c_2, c_3 are called the coordinates of \vec{u} relative to the basis S . The coordinate vector of \vec{u} relative to S is denoted by $[\vec{u}]_S$ and defined to be the following vector in \mathbb{R}^3 , $[\vec{u}]_S = (c_1, c_2, c_3)$. The coordinate vector of vector \vec{u} is unique.

Example 6.15

Determine the coordinate vector of $\vec{x} = (10, 5, 0)$ relative to the following bases:

- a) The standard basis vectors for \mathbb{R}^3
- b) The basis $A = \{\vec{e}_1 = (1, -1, 1), \vec{e}_2 = (0, 1, 2), \vec{e}_3 = (3, 0, -1)\}$

Solution

In each case, we will need to determine how to write $\vec{x} = (10, 5, 0)$ as a linear combination of the given basis vectors.

- a) The standard basis vectors for \mathbb{R}^3 is $\{\vec{e}_1 = (1, 0, 0), \vec{e}_2 = (0, 1, 0), \vec{e}_3 = (0, 0, 1)\}$

In this case, the linear combination is simple to write down.

$$\vec{x} = (10, 5, 0) = 10(1, 0, 0) + 5(0, 1, 0) + 0(0, 0, 1)$$

And so, the coordinate vector for x relative to the standard basis vectors is $[\vec{x}]_s = (10, 5, 0)$. So, in the case of the standard basis vectors, we have got that $[\vec{x}]_s = (10, 5, 0) = \vec{x}$

This is, of course, what makes the standard basis vectors so nice to work with. The coordinate vectors relative to the standard basis vectors is just the vector itself.

$$\text{b) The basis } A = \{\vec{e}_1 = (1, -1, 1), \vec{e}_2 = (0, 1, 2), \vec{e}_3 = (3, 0, -1)\}$$

Now, in this case, we will have a little work to do. We will first need to set up the following vector equation; $(10, 5, 0) = c_1(1, -1, 1) + c_2(0, 1, 2) + c_3(3, 0, -1)$ and we will need to determine the scalars c_1, c_2 , and c_3 . We saw how to solve this kind of vector equation in both the section on Span and the section on Linear Independence. We need to set up the following system of

$$\text{equations, } \begin{cases} c_1 + 3c_3 = 10 \\ -c_1 + c_2 = 5 \\ c_1 + 2c_2 - c_3 = 0 \end{cases} \Rightarrow \begin{cases} c_1 = -2 \\ c_2 = 3 \\ c_3 = 4 \end{cases}$$

The coordinate vector for x relative to A is then, $[\vec{x}]_A = (-2, 3, 4)$

Application Activity 6.4

- Find the coordinate vector of the vector $\vec{u} = (3, 1, -4)$ and $\vec{v} = (3, -2, 1)$ relative to the basis $V = \{(1, 1, 1), (0, 1, 1), (0, 0, 1)\}$.
- Find the coordinate vector of \vec{v} relative to the basis $\{(1, 1, 1), (1, 1, 0), (1, 0, 0)\}$ where
 - $\vec{v} = (4, -3, 2)$
 - $\vec{v} = (a, b, c)$
- Let V be the vector space of polynomials with degree less than or equal to 2: $V = \{at^2 + bt + c; a, b, c \in \mathbb{R}\}$. Find the coordinate vector of $\vec{v} = 2t^2 - 5t + 6$ relative to the basis $\{\vec{e}_1, \vec{e}_2, \vec{e}_3\}$ where $\vec{e}_1 = 1, \vec{e}_2 = t - 1$ and $\vec{e}_3 = (t - 1)^2$

4. Let $\{\vec{e}_1, \vec{e}_2, \vec{e}_3\}$ and $\{\vec{f}_1, \vec{f}_2, \vec{f}_3\}$ be bases of vector space V .

Suppose

$$\vec{e}_1 = a_1\vec{f}_1 + a_2\vec{f}_2 + a_3\vec{f}_3$$

$$\vec{e}_2 = b_1\vec{f}_1 + b_2\vec{f}_2 + b_3\vec{f}_3$$

$$\vec{e}_3 = c_1\vec{f}_1 + c_2\vec{f}_2 + c_3\vec{f}_3$$

Let A be the matrix whose rows are the coordinate vectors of \vec{e}_1, \vec{e}_2 and \vec{e}_3 respectively, relative to the basis $\{\vec{f}_1, \vec{f}_2, \vec{f}_3\}$

$$A = \begin{pmatrix} a_1 & a_2 & a_3 \\ b_1 & b_2 & b_3 \\ c_1 & c_2 & c_3 \end{pmatrix}$$

Show that, for any vector $\vec{v} \in V$, $[\vec{v}]_e A = [\vec{v}]_f$

6.2. Euclidian vector space \mathbb{R}^3

6.2.1. Scalar product of two vectors



Activity 6.5

Use the formula $(a, b, c) \cdot (d, e, f) = ad + be + cf$ to find

a) $(2, 3, 4) \cdot (1, -2, 1)$ b) $(1, -2, 4) \cdot (1, 0, -1)$

The scalar product or dot product (or sometimes inner product) is an algebraic operation that takes two coordinate vectors and returns a single number. That is, the scalar product of two vectors of space is the application $E_0 \times E_0 \rightarrow \mathbb{R}$.

Algebraically, it is the sum of the products of the corresponding coordinates of the two vectors. That is, the scalar product of vectors $\vec{u} = (a_1, a_2, a_3)$ and $\vec{v} = (b_1, b_2, b_3)$ of space is defined by $\vec{u} \cdot \vec{v} = a_1b_1 + a_2b_2 + a_3b_3$.

Properties of scalar product

$$\forall \vec{u}, \vec{v} \in E_0$$

a) If $\vec{u} = \vec{0}$ or $\vec{v} = \vec{0}$, then $\vec{u} \cdot \vec{v} = 0$

b) If $\vec{u} \parallel \vec{v}$ and \vec{u}, \vec{v} have same direction, then $\vec{u} \cdot \vec{v} > 0$

Consequences

a) $\forall \vec{u} \in E_0$, if $\vec{u} = \vec{0}$ then $\|\vec{u}\| = 0$

b) $\forall \vec{u} \in E_0, k \in \mathbb{R}$, $\|k\vec{u}\| = |k|\|\vec{u}\|$ where $|k|$ is the absolute value of k

c) **Distance between two points:** If A and B are two points, we can form a vector \overrightarrow{AB} and the distance between these two points denoted $d(A, B)$ is given by $\|\overrightarrow{AB}\|$. Thus, if $A(a_1, a_2, a_3)$ and $B(b_1, b_2, b_3)$ then

$$d(A, B) = \|\overrightarrow{AB}\| = \sqrt{(b_1 - a_1)^2 + (b_2 - a_2)^2 + (b_3 - a_3)^2}$$

d) Consider two vectors \vec{u} and \vec{v} on the same line:

If they have the same direction then $\vec{u} \cdot \vec{v} = \|\vec{u}\|\|\vec{v}\|$

If they have the opposite direction then $\vec{u} \cdot \vec{v} = -\|\vec{u}\|\|\vec{v}\|$

e) Let θ be the angle between two vectors \vec{u} and \vec{v} .

If θ is an obtuse angle, then the scalar product $\vec{u} \cdot \vec{v}$ is negative.

If θ is an acute angle, then the scalar product $\vec{u} \cdot \vec{v}$ is positive.

f) **Unit vector:** A vector \vec{u} is said to be unit vector if and only if its magnitude is 1. That is $\|\vec{u}\| = 1$.

g) **Normalised vector:** The normalized vector of a vector is a vector in the same direction but with magnitude 1. It is also called the unit vector. Given a vector \vec{v} , the normalized vector parallel to \vec{v} and with same direction is given by $\frac{\vec{v}}{\|\vec{v}\|}$.

Remark

A vector is said to be **normal vector** or simply the **normal** to a surface if it is perpendicular to that surface. Often, the normal unit vector is desired, which is sometimes known as the **unit normal**.

The terms normal vector and normalized vector should not be confused, especially since unit normal vectors might be called normalized normal vectors without redundancy.

Example 6.17

The magnitude of $\vec{u} = (3, 2, 4)$ is $\|\vec{u}\| = \sqrt{9 + 4 + 16} = \sqrt{29}$.

Example 6.18

The distance between $A(1, -1, 3)$ and $B(2, 4, 5)$ is

$$d(A, B) = \sqrt{(2-1)^2 + (4+1)^2 + (5-3)^2} = \sqrt{1+25+4} = \sqrt{30}$$

Example 6.19

The normalized vector parallel to $\vec{v} = (2, 4, 4)$ and with the same

direction is given by $\vec{e} = \frac{\vec{v}}{\|\vec{v}\|} = \frac{1}{\|\vec{v}\|} \vec{v} = \frac{1}{\sqrt{4+16+16}} \vec{v} = \frac{1}{6} (2, 4, 4)$

which is $\vec{e} = \left(\frac{1}{3}, \frac{2}{3}, \frac{2}{3}\right)$.

Application Activity 6.6

Find the magnitude of;

a) $\vec{u} = (21, 4, -2)$

b) $\vec{u} = (3, 3, 3)$

c) $\vec{u} = (22, 0, 0)$

d) $\vec{u} = (1, -2, -14)$

6.2.3. Angle between two vectors**Activity 6.7**

Consider two vectors $\vec{u} = (2, 2, 2)$ and $\vec{v} = (3, 3, 3)$

1. Find the scalar product $\vec{u} \cdot \vec{v}$

2. Find the product $\|\vec{u}\| \|\vec{v}\|$

3. Evaluate $\cos^{-1} \left(\frac{\vec{u} \cdot \vec{v}}{\|\vec{u}\| \|\vec{v}\|} \right)$

Suppose that a person is holding a heavy weight at rest. This person may say and feel he is doing hard work but in fact none is being done on the weight in the scientific sense. Work is done

when a force moves its point of application along the direction of its line of action.

If the constant force F and the displacement S are in the same direction we define the work W done by the force on the body by $W = F \cdot S$

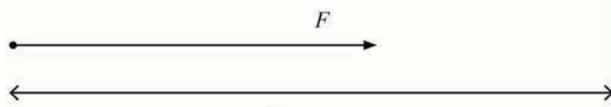

Consider two non zero vectors \vec{u} and \vec{v} . Geometrically, the scalar product of \vec{u} and \vec{v} is the product of their magnitudes and the cosine of the angle between them. That is, the scalar product of

vectors \vec{u} and \vec{v} is also defined to be $\vec{u} \cdot \vec{v} = \|\vec{u}\| \cdot \|\vec{v}\| \cdot \cos(\vec{u}, \vec{v})$.

From this definition, we can write $\cos(\vec{u}, \vec{v}) = \frac{\vec{u} \cdot \vec{v}}{\|\vec{u}\| \cdot \|\vec{v}\|}$.

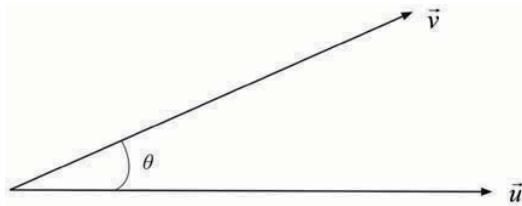

Note that when we are calculating the angle between two vectors, we calculate the smallest positive angle.

Properties

- ⊙ If the two vectors are perpendicular, their scalar product is zero mean that the angle between them is $\frac{\pi}{2}$ (if the second is upward) or $-\frac{\pi}{2}$ (if the second is downward). Thus, if $\vec{u} \perp \vec{v}$ then $\vec{u} \cdot \vec{v} = 0$.
- ⊙ If the two vectors are parallel, then $\vec{u} \cdot \vec{v} = \|\vec{u}\| \|\vec{v}\|$ or $\vec{u} \cdot \vec{v} = -\|\vec{u}\| \|\vec{v}\|$, meaning that the angle between them is 0 (if they have the same direction) or π (if they have the opposite direction).

Example 6.20

Consider the vector $\vec{u} = (3, 8, 1)$. What is the measure of the angle between this vector and z-axis of coordinates system?

Solution

$$\vec{u} = (3, 8, 1)$$

Take the normal vector on z-axis, $\vec{e} = (0, 0, 1)$

We need $\theta = \angle(\vec{u}, \vec{e})$.

$$\cos \theta = \frac{\vec{u} \cdot \vec{e}}{\|\vec{u}\| \|\vec{e}\|} = \frac{1}{\sqrt{9+64+1} \cdot \sqrt{1}} = \frac{1}{\sqrt{74}}$$

$$\cos \theta = \frac{1}{\sqrt{74}} \Leftrightarrow \theta = \arccos \frac{1}{\sqrt{74}} = 83.3^\circ$$

**Notice****Direction cosine**

Direction cosine (or directional cosine) of a vector is the angles between the vector and the three coordinates axes. Or equivalently, it is the component contribution of the basis to the unit vector.

The direction cosines of the vector $\vec{v} = (x, y, z)$ are

$$\cos \alpha = \frac{x}{\sqrt{x^2 + y^2 + z^2}}, \quad \cos \beta = \frac{y}{\sqrt{x^2 + y^2 + z^2}} \quad \text{and}$$

$$\cos \gamma = \frac{z}{\sqrt{x^2 + y^2 + z^2}}.$$

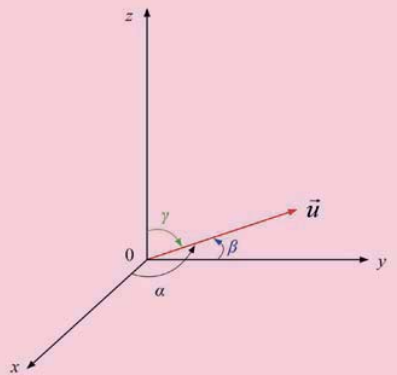

Note that the sum of squares of direction cosines of a vector is 1.

$$\text{In fact, } \cos^2 \alpha + \cos^2 \beta + \cos^2 \gamma = \frac{x^2}{x^2 + y^2 + z^2} + \frac{y^2}{x^2 + y^2 + z^2} + \frac{z^2}{x^2 + y^2 + z^2}$$

$$= \frac{x^2 + y^2 + z^2}{x^2 + y^2 + z^2} = 1$$

Thus, $\cos^2 \alpha + \cos^2 \beta + \cos^2 \gamma = 1$

Example 6.21

Determine the direction cosines of the vector with components $(1, 2, -3)$.

Solution

$$\cos \alpha = \frac{1}{\sqrt{1^2 + 2^2 + (-3)^2}} = \frac{1}{\sqrt{14}}$$

$$\cos \beta = \frac{2}{\sqrt{1^2 + 2^2 + (-3)^2}} = \frac{2}{\sqrt{14}}$$

$$\cos \gamma = \frac{-3}{\sqrt{1^2 + 2^2 + (-3)^2}} = \frac{-3}{\sqrt{14}}$$

Application Activity 6.7

1. Find the angle formed by the vectors:

a) $\vec{u} = (2, 3, 4)$ and $\vec{v} = (12, -3, 0)$

b) $\vec{u} = (1, -2, -14)$ and $\vec{v} = (22, 0, 0)$

c) $\vec{u} = (21, 4, -2)$ and $\vec{v} = (0, -1, 0)$

d) $\vec{u} = (1, 0, 0)$ and $\vec{v} = (3, 3, 3)$

2. Find the direction cosines of the vector:

a) $\vec{u} = (2, 3, 4)$

b) $\vec{v} = (12, -3, 0)$

c) $\vec{u} = (1, -2, -14)$

d) $\vec{v} = (22, 0, 0)$

6.2.4. Vector product**Activity 6.8**

1. Consider vectors $\vec{u} = (2, -1, 3)$ and $\vec{v} = (1, 2, -1)$. Find vector \vec{w} that is perpendicular to both \vec{u} and \vec{v} .

2. Calculate the determinant

$$\begin{vmatrix} \vec{i} & \vec{j} & \vec{k} \\ 2 & -1 & 3 \\ 1 & 2 & -1 \end{vmatrix}$$

3. Comment on results in 1 and 2

The **vector product** (or **cross product** or **Gibbs vector product**) is a binary operation on two vectors in three-dimensional space. It results in a vector which is perpendicular to both of the vectors being multiplied and therefore normal to the plane containing them.

The direction of the resultant vector can be determined by the right-hand rule. The thumb and index finger held perpendicularly to one another represent the vectors and the middle finger held perpendicularly to the index and thumb indicates the direction of the cross vector.

Consider $\{\vec{i} = (1, 0, 0), \vec{j} = (0, 1, 0), \vec{k} = (0, 0, 1)\}$, a positive orthonormal basis of E_0 and two linearly independent vectors $\vec{u} = (a_1, a_2, a_3)$ and $\vec{v} = (b_1, b_2, b_3)$.

The vector product of \vec{u} and \vec{v} is denoted $\vec{u} \times \vec{v}$. From Activity 6.8,

$$\vec{u} \times \vec{v} = \begin{vmatrix} \vec{i} & \vec{j} & \vec{k} \\ a_1 & a_2 & a_3 \\ b_1 & b_2 & b_3 \end{vmatrix} = \begin{vmatrix} a_2 & a_3 \\ b_2 & b_3 \end{vmatrix} \vec{i} - \begin{vmatrix} a_1 & a_3 \\ b_1 & b_3 \end{vmatrix} \vec{j} + \begin{vmatrix} a_1 & a_2 \\ b_1 & b_2 \end{vmatrix} \vec{k}$$

Or

$$\vec{u} \times \vec{v} = \left(\begin{vmatrix} a_2 & a_3 \\ b_2 & b_3 \end{vmatrix}, -\begin{vmatrix} a_1 & a_3 \\ b_1 & b_3 \end{vmatrix}, \begin{vmatrix} a_1 & a_2 \\ b_1 & b_2 \end{vmatrix} \right)$$

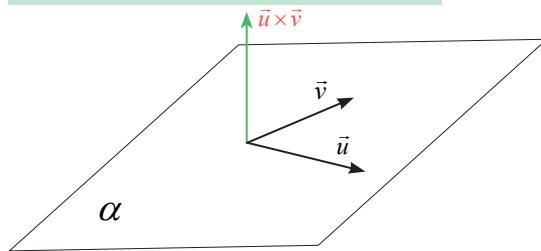

Example 6.22

Find the vector product of $\vec{u} = (2, 3, 5)$ and $\vec{v} = (-2, 5, 6)$

Solution

$$\vec{u} \times \vec{v} = \begin{vmatrix} \vec{i} & \vec{j} & \vec{k} \\ 2 & 3 & 5 \\ -2 & 5 & 6 \end{vmatrix} = \begin{vmatrix} 3 & 5 \\ 5 & 6 \end{vmatrix} \vec{i} - \begin{vmatrix} 2 & 5 \\ -2 & 6 \end{vmatrix} \vec{j} + \begin{vmatrix} 2 & 3 \\ -2 & 5 \end{vmatrix} \vec{k} = -7\vec{i} - 22\vec{j} + 16\vec{k}$$

Or

$$\vec{u} \times \vec{v} = (-7, -22, +16)$$

Properties of vector product

1. If \vec{w} is vector product \vec{u} and \vec{v} , then $\vec{w} \perp \vec{u}$ and $\vec{w} \perp \vec{v}$
2. The vector product is anti-symmetric: $\vec{u} \times \vec{v} = -\vec{v} \times \vec{u}$.
3. If $\vec{u} = \vec{0}$ and $\vec{v} = \vec{0}$ then $\vec{u} \times \vec{v} = \vec{0}$
4. If two vectors are linearly dependent, then their vector product is a zero vector.
5. If $\vec{u} \times \vec{v} = \vec{0}$ then $\vec{u} = \vec{0}$ or $\vec{v} = \vec{0}$
6. The vector product is bilinear: $\vec{u} \times (r\vec{v} + s\vec{w}) = r(\vec{u} \times \vec{v}) + s(\vec{u} \times \vec{w})$
 $(r\vec{u} + s\vec{v}) \times \vec{w} = r(\vec{u} \times \vec{w}) + s(\vec{v} \times \vec{w})$
7. The vector product is not associative: $(\vec{u} \times \vec{v}) \times \vec{w} \neq \vec{u} \times (\vec{v} \times \vec{w})$

Application Activity 6.8

Calculate the vector product $\vec{u} \times \vec{v}$ of the following vectors:

1. $\vec{u} = (1, 3, 1)$, $\vec{v} = (-1, 2, 1)$
2. $\vec{u} = (3, 3, 2)$, $\vec{v} = (5, 1, 0)$
3. $\vec{u} = (-3, 2, -1)$, $\vec{v} = (0, 1, 1)$
4. $\vec{u} = (10, 9, 6)$, $\vec{v} = (3, 11, 0)$
5. $\vec{u} = (8, 2, 2)$, $\vec{v} = (-1, -2, 2)$

6.2.5. Mixed product



Activity 6.9

Given that

$$\vec{v} \times \vec{w} = \begin{vmatrix} a_2 & a_3 \\ b_2 & b_3 \end{vmatrix} \vec{i} - \begin{vmatrix} a_1 & a_3 \\ b_1 & b_3 \end{vmatrix} \vec{j} + \begin{vmatrix} a_1 & a_2 \\ b_1 & b_2 \end{vmatrix} \vec{k}$$

where $\vec{i} = (1, 0, 0)$, $\vec{j} = (0, 1, 0)$, $\vec{k} = (0, 0, 1)$ and $\vec{u} = (c_1, c_2, c_3)$, find $\vec{u} \cdot (\vec{v} \times \vec{w})$

The mixed product (also called the **scalar triple product** or **box product** or **compound product**) of three vectors is a scalar which

numerically equals the vector product multiplied by a vector as the dot product.

Then the mixed product of the vectors $\vec{u} = (a_1, a_2, a_3)$, $\vec{v} = (b_1, b_2, b_3)$ and $\vec{w} = (c_1, c_2, c_3)$ is equal to dot product of the first vector by the vector product of the other two. It is denoted by $[\vec{u}, \vec{v}, \vec{w}]$.

Thus, $[\vec{u}, \vec{v}, \vec{w}] = \vec{u} \cdot (\vec{v} \times \vec{w})$

From Activity 6.9,

$$\vec{u} \cdot (\vec{v} \times \vec{w}) = a_1 \begin{vmatrix} b_2 & b_3 \\ c_2 & c_3 \end{vmatrix} - a_2 \begin{vmatrix} b_1 & b_3 \\ c_1 & c_3 \end{vmatrix} + a_3 \begin{vmatrix} b_1 & b_2 \\ c_1 & c_2 \end{vmatrix}$$

This product is equivalent to the development of a determinant whose columns are the coordinates of these vectors with respect to an orthonormal basis.

That is,

$$\vec{u} \cdot (\vec{v} \times \vec{w}) = \begin{vmatrix} a_1 & a_2 & a_3 \\ b_1 & b_2 & b_3 \\ c_1 & c_2 & c_3 \end{vmatrix}$$

Mixed product properties

1. The mixed product does not change if the orders of its factors are circularly rotated, but changes sign if they are transposed.

That is,

$$\begin{aligned} \odot \vec{u} \cdot (\vec{v} \times \vec{w}) &= \vec{w} \cdot (\vec{u} \times \vec{v}) = \vec{v} \cdot (\vec{w} \times \vec{u}) \\ \odot \vec{u} \cdot (\vec{v} \times \vec{w}) &= -\vec{w} \cdot (\vec{v} \times \vec{u}) = -\vec{v} \cdot (\vec{u} \times \vec{w}) \end{aligned}$$

2. If three vectors are linearly dependent, the mixed product is zero.

Example 6.23

Calculate the mixed product $\vec{u} \cdot (\vec{v} \times \vec{w})$ of the following vectors: $\vec{u} = (2, -1, 3)$, $\vec{v} = (0, 2, -5)$ and $\vec{w} = (1, -1, -2)$.

Solution

$$\vec{v} \times \vec{w} = \begin{vmatrix} \vec{i} & \vec{j} & \vec{k} \\ 0 & 2 & -5 \\ 1 & -1 & -2 \end{vmatrix} = -9\vec{i} - 5\vec{j} - 2\vec{k} = (-9, -5, -2)$$

$$\vec{u} \cdot (\vec{v} \times \vec{w}) = (2, -1, 3) \cdot (-9, -5, -2) = -18 + 5 - 6 = -19$$

$$\text{Or } \vec{u} \cdot (\vec{v} \times \vec{w}) = \begin{vmatrix} 2 & -1 & 3 \\ 0 & 2 & -5 \\ 1 & -1 & -2 \end{vmatrix} = -8 + 0 + 5 - 6 - 10 - 0 = -19$$

Application Activity 6.9

Calculate the mixed product $\vec{u} \cdot (\vec{v} \times \vec{w})$ of the following vectors:

- $\vec{u} = (1, 3, 1)$, $\vec{v} = (-1, 2, 1)$ and $\vec{w} = (1, 0, -1)$
- $\vec{u} = (3, 3, 2)$, $\vec{v} = (5, 1, 0)$ and $\vec{w} = (2, 1, -3)$
- $\vec{u} = (-3, 2, -1)$, $\vec{v} = (0, 1, 1)$ and $\vec{w} = (8, 0, 0)$
- $\vec{u} = (10, 9, 6)$, $\vec{v} = (3, 11, 0)$ and $\vec{w} = (1, 3, 4)$
- $\vec{u} = (8, 2, 2)$, $\vec{v} = (-1, -2, 2)$ and $\vec{w} = (6, 2, -2)$

6.3. Applications**Work done as scalar multiplication****Activity 6.10**

From the definition of work done by a force on a body, if a constant force F acting on a particle displaces from A to B , express the work done in function of vectors \vec{F} and \vec{AB} .

From Activity 6.10, if a constant force F acting on a particle displaces it from A to B , the work done is given by

$$\text{work done} = \vec{F} \cdot \vec{AB}$$

Example 6.24

Constant forces $\vec{P} = 2\vec{i} - 5\vec{j} + 6\vec{k}$ and $\vec{Q} = -\vec{i} + 2\vec{j} - \vec{k}$ act on a particle. Determine the work done when the particle is displaced from A to B , the position vectors of A and B being $4\vec{i} - 3\vec{j} + 2\vec{k}$ and $6\vec{i} + \vec{j} - 3\vec{k}$ respectively.

Solution

$$\text{Total force: } (2\vec{i} - 5\vec{j} + 6\vec{k}) + (-\vec{i} + 2\vec{j} - \vec{k}) = \vec{i} - 3\vec{j} + 5\vec{k}$$

$$\text{Displacement: } (6\vec{i} + \vec{j} - 3\vec{k}) - (4\vec{i} - 3\vec{j} + 2\vec{k}) = 2\vec{i} + 4\vec{j} - 5\vec{k}$$

$$\text{Work done: } (\vec{i} - 3\vec{j} + 5\vec{k}) \cdot (2\vec{i} + 4\vec{j} - 5\vec{k}) = 2 - 12 - 25 = -35$$

Work done is 35 unit of work.

Example 6.25

Forces of magnitudes 5 and 3 units acting in the direction $6\vec{i} + 2\vec{j} + 3\vec{k}$ and $3\vec{i} - 2\vec{j} + 6\vec{k}$ respectively act on a particle which is displaced from the point $(2, 2, -1)$ to $(4, 3, 1)$. Find the work done by the forces.

Solution

First force of magnitude 5 units, acting in the direction $6\vec{i} + 2\vec{j} + 3\vec{k}$

$$\text{is } 5 \frac{6\vec{i} + 2\vec{j} + 3\vec{k}}{\sqrt{6^2 + 2^2 + 3^2}} = \frac{5}{7}(6\vec{i} + 2\vec{j} + 3\vec{k})$$

Second force of magnitude 3 units, acting in the direction

$$3\vec{i} - 2\vec{j} + 6\vec{k} \text{ is } 3 \frac{3\vec{i} - 2\vec{j} + 6\vec{k}}{\sqrt{3^2 + (-2)^2 + 6^2}} = \frac{3}{7}(3\vec{i} - 2\vec{j} + 6\vec{k})$$

$$\text{Resulting force is } \frac{5}{7}(6\vec{i} + 2\vec{j} + 3\vec{k}) + \frac{3}{7}(3\vec{i} - 2\vec{j} + 6\vec{k}) = \frac{1}{7}(39\vec{i} + 4\vec{j} + 33\vec{k})$$

Displaced from the point $(2, 2, -1)$ to $(4, 3, 1)$ is

$$(4\vec{i} + 3\vec{j} + \vec{k}) - (2\vec{i} + 2\vec{j} - \vec{k}) = 2\vec{i} + \vec{j} + 2\vec{k}$$

$$\text{Work done: } \frac{1}{7}(39\vec{i} + 4\vec{j} + 33\vec{k}) \cdot (2\vec{i} + \vec{j} + 2\vec{k}) = \frac{1}{7}(78 + 4 + 66) = \frac{148}{7}$$

Application Activity 6.10

1. A particle acted on by constant forces $2\vec{i} + \vec{j} - \vec{k}$, $\vec{i} - 2\vec{j} + 3\vec{k}$ and $3\vec{i} + \vec{j} + 5\vec{k}$ is displaced from the point $\vec{i} + 2\vec{j} + 3\vec{k}$ to the point $6\vec{i} + 3\vec{j} + \vec{k}$. Find the work done.
2. Constant forces $12\vec{i} - 15\vec{j} + 6\vec{k}$, $\vec{i} + 2\vec{j} - 2\vec{k}$ and $2\vec{i} + 8\vec{j} + \vec{k}$ act on a point P which is displaced from the position $2\vec{i} - 3\vec{j} + \vec{k}$ to the position $4\vec{i} + 2\vec{j} + \vec{k}$. Find the total work done.
3. The point of application of force $(-2, 4, 7)$ is displaced from the point $(3, -5, 1)$ to the point $(5, 9, 7)$. But the force is suddenly halved when the point of application moves half the distance. Find the work done.
4. A force of magnitude 6 units acting parallel to $2\vec{i} - 2\vec{j} + \vec{k}$ displaces the point of application from $(1, 2, 3)$ to $(5, 3, 7)$. Find the work done.
5. A particle acted on by two forces $4\vec{i} + \vec{j} - 3\vec{k}$ and $3\vec{i} + \vec{j} - \vec{k}$ is displaced from the point $\vec{i} + 2\vec{j} + \vec{k}$ to the point $5\vec{i} + 4\vec{j} + \vec{k}$. Find the work done by the forces.
6. A particle is acted upon by constant forces $4\vec{i} + \vec{j} - 3\vec{k}$ and $3\vec{i} + \vec{j} - \vec{k}$ and is displaced from point $(1, 2, 3)$ to the point $(5, 4, 1)$. Find the total work spent by the forces.

Area of a parallelogram**Activity 6.11**

Consider the following figure

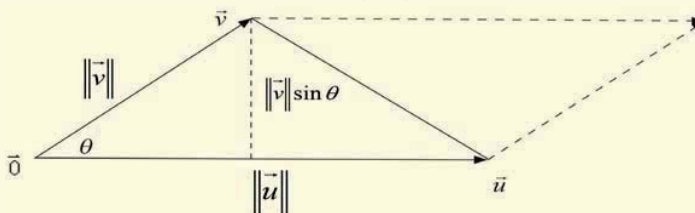

Write down the formula for area of this parallelogram in terms of $\|\vec{u}\|$, $\|\vec{v}\|$ and $\sin\theta$ and give its equivalent relation using vector product.

Geometrically, the magnitude of the vector product of two vectors is the product of their magnitudes and the sine of the angle between them.

From Activity 6.11, the area of a parallelogram with vectors \vec{u} and \vec{v} as two adjacent sides is given by $S_{\square} = \|\vec{u} \times \vec{v}\|$.

Thus, the magnitude of the vector product of two vectors \vec{u} and \vec{v} represents the area of a parallelogram with vectors \vec{u} and \vec{v} as two adjacent sides.

Example 6.26

Find the area of parallelogram with vectors $\vec{u} = (3, 0, 4)$ and $\vec{v} = (3, 2, 1)$ as two adjacent sides.

Solution

$$\vec{u} \times \vec{v} = \begin{vmatrix} \vec{i} & \vec{j} & \vec{k} \\ 3 & 0 & 4 \\ 3 & 2 & 1 \end{vmatrix} = \begin{vmatrix} 0 & 4 \\ 2 & 1 \end{vmatrix} \vec{i} - \begin{vmatrix} 3 & 4 \\ 3 & 1 \end{vmatrix} \vec{j} + \begin{vmatrix} 3 & 0 \\ 3 & 2 \end{vmatrix} \vec{k} = -8\vec{i} + 9\vec{j} + 6\vec{k}$$

$$S_{\square} = \|\vec{u} \times \vec{v}\| = \|-8\vec{i} + 9\vec{j} + 6\vec{k}\| = \sqrt{64 + 81 + 36} = \sqrt{181} \quad \text{squared units}$$



Notice

Area of a triangle

Since the area of the parallelogram is twice the area of the triangle, we may use the vector product to find the area of triangle.

Thus, the area of triangle with vectors \vec{u} and \vec{v} as two sides is

$$S_{\triangle} = \frac{1}{2} \|\vec{u} \times \vec{v}\|.$$

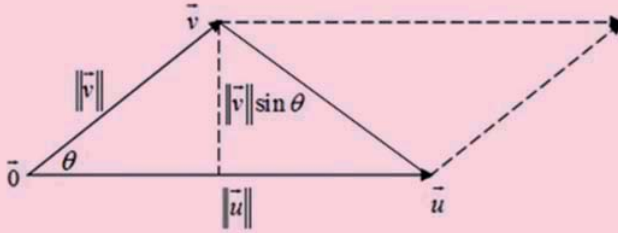

Consider the triangle ABC whose vertices are points $A(a_1, a_2, a_3)$, $B(b_1, b_2, b_3)$ and $C(c_1, c_2, c_3)$. Letting A to be the starting point, we can form two vectors \overrightarrow{AB} and \overrightarrow{AC} and the area of this triangle is $S_{\Delta} = \frac{1}{2} \|\overrightarrow{AB} \times \overrightarrow{AC}\|$.

Example 6.27

Find the area of triangle with vectors $\vec{u} = (3, 0, 4)$ and $\vec{v} = (3, 2, 1)$ as two sides.

Solution

$$\vec{u} \times \vec{v} = \begin{vmatrix} \vec{i} & \vec{j} & \vec{k} \\ 3 & 0 & 4 \\ 3 & 2 & 1 \end{vmatrix} = \begin{vmatrix} 0 & 4 \\ 2 & 1 \end{vmatrix} \vec{i} - \begin{vmatrix} 3 & 4 \\ 3 & 1 \end{vmatrix} \vec{j} + \begin{vmatrix} 3 & 0 \\ 3 & 2 \end{vmatrix} \vec{k} = -8\vec{i} + 9\vec{j} + 6\vec{k}$$

$$S_{\Delta} = \frac{1}{2} \|\vec{u} \times \vec{v}\| = \frac{1}{2} \|-8\vec{i} + 9\vec{j} + 6\vec{k}\| = \frac{1}{2} \sqrt{64 + 81 + 36} = \frac{1}{2} \sqrt{181} \text{ Sq. units}$$

Application Activity 6.11

- Find the area of a parallelogram with vectors
 - $\vec{u} = (1, -2, -14)$ and $\vec{v} = (22, 0, 0)$ as two adjacent sides
 - $\vec{u} = (21, 4, -2)$ and $\vec{v} = (0, -1, 0)$ as two adjacent sides
- Find the area of triangle with vectors $\vec{u} = (1, 0, 0)$ and $\vec{v} = (3, 3, 3)$ as two sides.
- Find the area of a parallelogram whose sides are formed by the vectors $\vec{u} = (2, -3, 1)$ and $\vec{v} = (1, 4, 5)$.

- Find the area of a parallelogram determined by the vectors $\vec{u} = (1, 2, 3)$ and $\vec{v} = (-3, -2, 1)$.
- Find the area of triangle formed by the points whose position vectors are $3\vec{i} + \vec{j}$, $5\vec{i} + 2\vec{j} + \vec{k}$, $\vec{i} - 2\vec{j} + 3\vec{k}$.
- The vertices of a triangle are $(1, 1, 1)$, $(0, 1, 2)$ and $(3, 2, 1)$. Find the area of the triangle.

Volume of a parallelepiped

Activity 6.12



Consider the following figure:

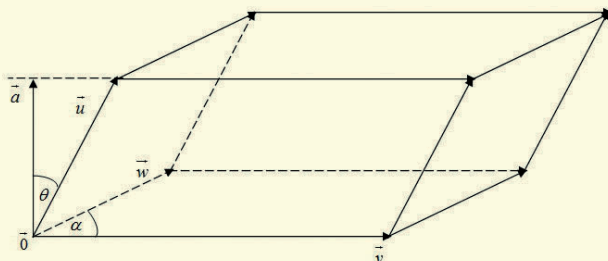

Write down the formula for volume of this parallelepiped in terms of $\|\vec{u}\|$, $\|\vec{v}\|$, $\|\vec{w}\|$, $\cos\theta$ and $\sin\alpha$ and give its equivalent relation using mixed product.

Geometrically, the magnitude of the mixed product represents the volume of the parallelepiped whose edges are three vectors that meet in the same vertex.

From Activity 6.12, for a parallelepiped which has vectors \vec{u} , \vec{v} and \vec{w} as three concurrent edges, where \vec{v} and \vec{w} define its base, the volume is given by $V = \left| \vec{u} \cdot (\vec{v} \times \vec{w}) \right|$

Remember that if $\vec{u} = (a_1, a_2, a_3)$, $\vec{v} = (b_1, b_2, b_3)$ and $\vec{w} = (c_1, c_2, c_3)$,

$$\text{then } \vec{u} \cdot (\vec{v} \times \vec{w}) = \begin{vmatrix} a_1 & a_2 & a_3 \\ b_1 & b_2 & b_3 \\ c_1 & c_2 & c_3 \end{vmatrix}.$$

If the parallelepiped is defined by four points $A(a_1, a_2, a_3)$, $B(b_1, b_2, b_3)$, $C(c_1, c_2, c_3)$ and $D(d_1, d_2, d_3)$, its volume is

$$V = \left| \overrightarrow{AD} \cdot (\overrightarrow{AB} \times \overrightarrow{AC}) \right|$$

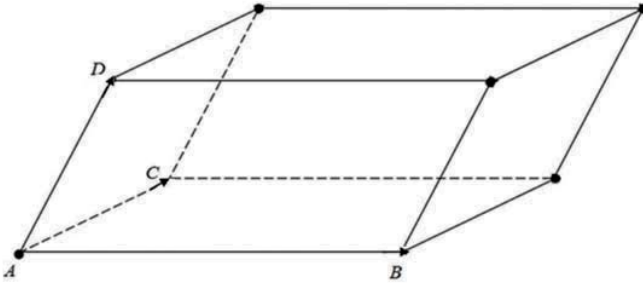

Example 6.28

Find the volume of the parallelepiped formed by the vectors: $\vec{u} = (3, -2, 5)$, $\vec{v} = (2, 2, -1)$ and $\vec{w} = (-4, 3, 2)$.

Solution

$$V = \vec{u} \cdot (\vec{v} \times \vec{w}) = \begin{vmatrix} 3 & -2 & 5 \\ 2 & 2 & -1 \\ -4 & 3 & 2 \end{vmatrix} = 12 + 30 - 8 + 40 + 9 + 8 = 91 \text{ cubic units}$$

Example 6.29

Consider the following cube with vertices $a, b, c, d, a', b', 0, c'$

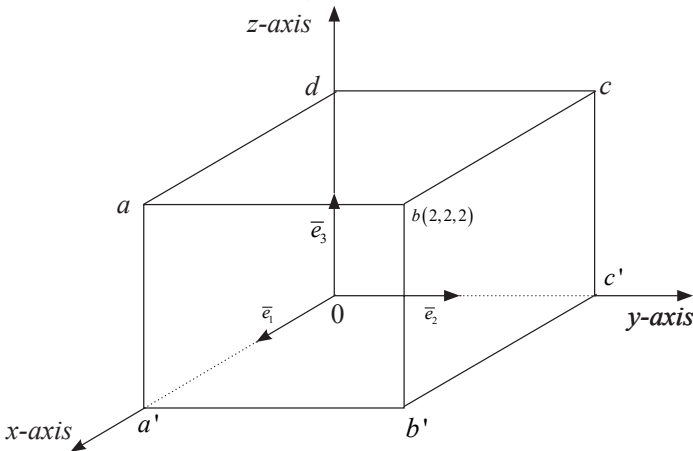

From coordinates of the vertex b , find the coordinates of other vertices.

- a) Calculate the area of triangle $a'bc'$.
- b) Calculate the volume of this cube.

Solution

a) First: the vertices a',c',d are intercepts of coordinate axes.

a' is x -axis intercept. It has the form $a'(m,0,0)$

c' is y -axis intercept. It has the form $c'(0,n,0)$

d is z -axis intercept. It has the form $d(0,0,k)$

Second: considering the xy -plane and the given figure, vertex b is 2 units upwards, means that the vertices a,c and d are also 2 units upward since the figure is a cube. Then the z -coordinate of a,c and d are the same and equal to **2**.

Third: considering the xz -plane and the given figure, vertex b is 2 units in direction of y -positive, mean that the vertices b',c and c' are also 2 units in direction of y -positive since the figure is a cube. Then the y -coordinate of b',c and c' are the same and equal to **2**.

Fourth: considering the yz -plane and the given figure, vertex b is 2 units in direction of x -positive, mean that the vertices a,a' and b' are also 2 units in direction of x -positive since the figure is a cube. Then the x -coordinate of a,a' and b' are the same and equal to **2**.

Fifth: vertex a lies on xz plane, thus its y -coordinate is zero. Vertex c lies on yz plane, thus its x -coordinate is zero. Vertex b' lies on xy plane, thus its z -coordinate is zero.

Combining the above results we get:

$$a(2,0,2), a'(2,0,0), b'(2,2,0), c(0,2,2), c'(0,2,0) \text{ and } d(0,0,2)$$

b) Area of triangle $a'bc'$

This triangle is built from vectors $\overrightarrow{a'b}$ and $\overrightarrow{a'c'}$. The area is given by $\frac{1}{2}\|\overrightarrow{a'b} \times \overrightarrow{a'c'}\|$.

$$\overrightarrow{a'b} = (0, 2, 2), \quad \overrightarrow{a'c'} = (-2, 2, 0)$$

$$\overrightarrow{a'b} \times \overrightarrow{a'c'} = \begin{vmatrix} \vec{i} & \vec{j} & \vec{k} \\ 0 & 2 & 2 \\ -2 & 2 & 0 \end{vmatrix} = -4\vec{i} - 4\vec{j} + 4\vec{k}$$

The area is $\frac{1}{2}\|\overrightarrow{a'b} \times \overrightarrow{a'c'}\| = \frac{1}{2}\sqrt{16+16+16} = 2\sqrt{3}$ sq. units.

c) The volume of the given cube is:

$$V = \left| \vec{d} \cdot (\overrightarrow{a'} \times \overrightarrow{c'}) \right|$$

$$V = \begin{vmatrix} 0 & 0 & 2 \\ 2 & 0 & 0 \\ 0 & 2 & 0 \end{vmatrix} = 0 + 8 + 0 - 0 - 0 - 0 = 8 \text{ cubic units.}$$

Remark

A parallelepiped is a prism (or polyhedron) which has a parallelogram as its base.

**Notice****Volume of a triangular prism**

The parallelepiped can be split into 2 triangular prism of equal volume. Since the volume of a parallelepiped is the magnitude of the mixed product, then the volume of a triangular prism is equal to $\frac{1}{2}$ of the magnitude of the mixed product.

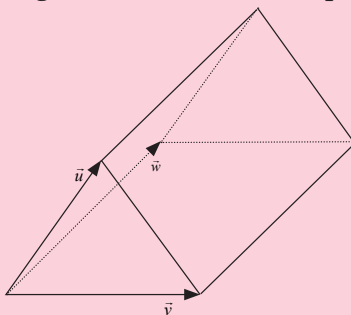

Thus, the volume of a triangular prism which has vectors $\vec{u} = (a_1, a_2, a_3)$, $\vec{v} = (b_1, b_2, b_3)$ and $\vec{w} = (c_1, c_2, c_3)$, as three concurrent edges, where \vec{v} and \vec{w} define its base, is given by

$$V = \frac{1}{2} \begin{vmatrix} a_1 & a_2 & a_3 \\ b_1 & b_2 & b_3 \\ c_1 & c_2 & c_3 \end{vmatrix} = \frac{1}{2} \left(\begin{vmatrix} b_2 & b_3 \\ c_2 & c_3 \end{vmatrix} a_1 - \begin{vmatrix} b_1 & b_3 \\ c_1 & c_3 \end{vmatrix} a_2 + \begin{vmatrix} b_1 & b_2 \\ c_1 & c_2 \end{vmatrix} a_3 \right)$$

Example 6.30

Find the volume of a triangular prism whose vertices are the points $A(1, 2, 1)$, $B(2, 4, 0)$, $C(-1, 2, 1)$ and $D(2, -2, 2)$.

Solution

$$\overline{AB} = (1, 2, -1) \quad \overline{AC} = (-2, 0, 0)$$

$$\overline{AD} = (1, -4, 1)$$

The volume is

$$V = \frac{1}{2} \begin{vmatrix} 1 & 2 & -1 \\ -2 & 0 & 0 \\ 1 & -4 & 1 \end{vmatrix} = \frac{1}{2} (0 - 8 + 0 - 0 - 0 + 4) = -2$$

We need to take absolute value. Thus, the volume is $V=2$ cubic units

Volume of a tetrahedron

The parallelepiped can be split into 6 tetrahedra of equal volume. Since the volume of a parallelepiped is the magnitude of the mixed product, then the volume of a tetrahedron is equal to $\frac{1}{6}$ of the magnitude of the mixed product.

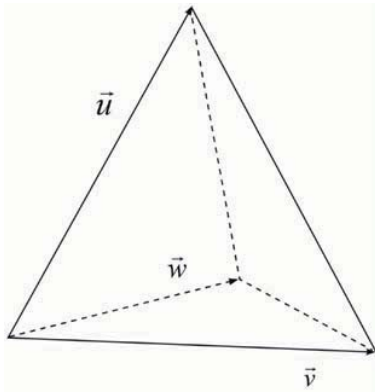

Thus, the volume of a tetrahedron which has vectors $\vec{u} = (a_1, a_2, a_3)$, $\vec{v} = (b_1, b_2, b_3)$ and $\vec{w} = (c_1, c_2, c_3)$, as three concurrent edges, where \vec{v} and \vec{w} define its base, is given by

$$V = \frac{1}{6} \begin{vmatrix} a_1 & a_2 & a_3 \\ b_1 & b_2 & b_3 \\ c_1 & c_2 & c_3 \end{vmatrix}$$

Remark

A tetrahedron is also called **triangular pyramid**.

Example 6.31

Find the volume of the tetrahedron whose vertices are the points $A(3,2,1)$, $B(1,2,4)$, $C(4,0,3)$ and $D(1,1,7)$.

Solution

$$\vec{AB} = (-2, 0, 3) \quad \vec{AC} = (1, -2, 2) \quad \vec{AD} = (-2, -1, 6)$$

The volume is

$$V = \frac{1}{6} \begin{vmatrix} -2 & 0 & 3 \\ 1 & -2 & 2 \\ -2 & -1 & 6 \end{vmatrix} = \frac{1}{6} (24 - 3 + 0 - 12 - 4 - 0) = \frac{5}{6} \text{ cubic units}$$

Application Activity 6.12

- Find the volume of a triangular prism whose vertices are the points:
 - $A(1,2,1)$, $B(0,-2,4)$, $C(1,1,1)$ and $D(1,6,4)$.
 - $A(-1,3,1)$, $B(0,-1,0)$, $C(3,1,2)$ and $D(1,2,4)$.
- Find the volume of the tetrahedron whose vertices are the points:
 - $A(3,1,4)$, $B(1,0,0)$, $C(3,4,1)$ and $D(1,0,2)$.
 - $A(-1,-2,1)$, $B(-5,2,3)$, $C(1,1,1)$ and $D(1,1,0)$.

- Find the volume of the parallelepiped with adjacent sides $\overrightarrow{OA} = 3\vec{i} - \vec{j}$, $\overrightarrow{OB} = \vec{j} + 2\vec{k}$, $\overrightarrow{OC} = \vec{i} + 5\vec{j} + 4\vec{k}$ extending from origin of coordinates.
- Find the volume of the tetrahedron whose vertices are the points $A(2, -1, -3)$, $B(4, 1, 3)$, $C(3, 2, -1)$ and $D(1, 4, 2)$

Unit Summary

- The vector \overrightarrow{AB} defined by two points $A(a_1, a_2, a_3)$ and $B(b_1, b_2, b_3)$ is given by $\overrightarrow{AB} = (b_1, b_2, b_3) - (a_1, a_2, a_3)$ which is $\overrightarrow{AB} = (b_1 - a_1, b_2 - a_2, b_3 - a_3)$.
- If $\vec{a} = (a_1, a_2, a_3)$, $\vec{b} = (b_1, b_2, b_3)$, $\vec{a} + \vec{b} = (a_1 + b_1, a_2 + b_2, a_3 + b_3)$
- If $\vec{a} = (a_1, a_2, a_3)$, $\vec{b} = (b_1, b_2, b_3)$, $\vec{a} - \vec{b} = (a_1 - b_1, a_2 - b_2, a_3 - b_3)$
- If $\vec{a} = (a_1, a_2, a_3)$, $\lambda\vec{a} = (\lambda a_1, \lambda a_2, \lambda a_3)$
- If $(\mathbb{R}, F, +)$ is a sub-space of $(\mathbb{R}, E, +)$, then
 - ⊙ $F \subset E$
 - ⊙ $\vec{0} \in F$
 - ⊙ $\vec{u}, \vec{v} \in F, \alpha, \beta \in \mathbb{R}; \alpha\vec{u} + \beta\vec{v} \in F$
- The vector \vec{u} is called a linear combination of the vectors $\vec{u}_1, \vec{u}_2, \vec{u}_3$ provided that there exists scalars c_1, c_2, c_3 such that $\vec{u} = c_1\vec{u}_1 + c_2\vec{u}_2 + c_3\vec{u}_3$
- Let $S = \{\vec{u}_1, \vec{u}_2, \vec{u}_3\}$ be a set of vectors in the vector space V. The set of all linear combinations of $\vec{u}_1, \vec{u}_2, \vec{u}_3$ is called the **span** of the set S, denoted by $span(S)$ or $span(\vec{u}_1, \vec{u}_2, \vec{u}_3)$.
The set $S = \{\vec{u}_1, \vec{u}_2, \vec{u}_3\}$ of vectors in the vector space V is a spanning set for V (or a generating set for V) provided that every vector in V is a linear combination of the vectors in S.
- The set of vectors $S = \{\vec{u}_1, \vec{u}_2, \vec{u}_3\}$ of a vector space V is said to be **linearly independent** provided that the equation $c_1\vec{u}_1 + c_2\vec{u}_2 + c_3\vec{u}_3 = \vec{0}$ has only the trivial solution $c_1 = c_2 = c_3 = 0$.

9. A set of vectors is called **linearly dependent** if it is not linearly independent. Or if $c_1u_1 + c_2u_2 + c_3u_3 = 0$ for $c_1, c_2, c_3 \neq 0$.
10. The scalar product of vectors $\vec{u} = (a_1, a_2, a_3)$ and $\vec{v} = (b_1, b_2, b_3)$ of space is defined by $\vec{u} \cdot \vec{v} = a_1b_1 + a_2b_2 + a_3b_3$.
11. If $\vec{u} = (a, b, c)$ then $\|\vec{u}\| = \sqrt{a^2 + b^2 + c^2}$.
12. If $A(a_1, a_2, a_3)$ and $B(b_1, b_2, b_3)$ then

$$d(A, B) = \|\overline{AB}\| = \sqrt{(b_1 - a_1)^2 + (b_2 - a_2)^2 + (b_3 - a_3)^2}$$
13. The scalar product of vectors \vec{u} and \vec{v} is also defined to be $\vec{u} \cdot \vec{v} = \|\vec{u}\| \cdot \|\vec{v}\| \cdot \cos(\vec{u}, \vec{v})$.
14. The vector product of \vec{u} and \vec{v} is denoted $\vec{u} \times \vec{v}$ and defined by
- $$\vec{u} \times \vec{v} = \begin{vmatrix} \vec{i} & \vec{j} & \vec{k} \\ a_1 & a_2 & a_3 \\ b_1 & b_2 & b_3 \end{vmatrix} = \begin{vmatrix} a_2 & a_3 \\ b_2 & b_3 \end{vmatrix} \vec{i} - \begin{vmatrix} a_1 & a_3 \\ b_1 & b_3 \end{vmatrix} \vec{j} + \begin{vmatrix} a_1 & a_2 \\ b_1 & b_2 \end{vmatrix} \vec{k}$$
15. The area of a parallelogram with vectors \vec{u} and \vec{v} as two adjacent sides is $S_{\square} = \|\vec{u} \times \vec{v}\|$
16. The area of triangle with vectors \vec{u} and \vec{v} as two sides is

$$S_{\Delta} = \frac{1}{2} \|\vec{u} \times \vec{v}\|$$
17. The mixed product of the vectors $\vec{u} = (a_1, a_2, a_3)$, $\vec{v} = (b_1, b_2, b_3)$ and $\vec{w} = (c_1, c_2, c_3)$ is denoted and defined by

$$[\vec{u} \ \vec{v} \ \vec{w}] = \vec{u} \cdot (\vec{v} \times \vec{w})$$
18. The volume of a parallelepiped which has vectors \vec{u} , \vec{v} and \vec{w} as three concurrent edges, where \vec{v} and \vec{w} define its base, is given by $V = \left| \vec{u} \cdot (\vec{v} \times \vec{w}) \right|$
19. The volume of a triangular prism which has vectors \vec{u} , \vec{v} and \vec{w} as three concurrent edges, where \vec{v} and \vec{w} define its base, is given by $V = \frac{1}{2} \left| \vec{u} \cdot (\vec{v} \times \vec{w}) \right|$
20. The volume of a tetrahedron which has vectors \vec{u} , \vec{v} and \vec{w} as three concurrent edges, where \vec{v} and \vec{w} define its base, is given by $V = \frac{1}{6} \left| \vec{u} \cdot (\vec{v} \times \vec{w}) \right|$

End of Unit Assessment

- With aid of diagrams, show that vectors are both associative and commutative under addition.
- In a regular hexagon $OABCDE$, the position vectors of A and B relative to O are \vec{a} and \vec{b} respectively. Find expressions in terms of \vec{a} and \vec{b} for the vectors \overrightarrow{AB} and \overrightarrow{BC} . Find also the position vectors of C , D and E .
- Determine whether the given set of vectors is linearly independent
 - $\{(1,0,0), (1,1,0), (1,1,1)\}$ in \mathbb{R}^3 .
 - $\{(1,-2,1), (3,-5,2), (2,-3,6), (1,2,1)\}$ in \mathbb{R}^3 .
 - $\{(1,-3,2), (2,-5,3), (4,0,1)\}$ in \mathbb{R}^3 .
- Are $(x-1)(x-2)$ and $|x-1|(x-2)$ linearly independent?
- Let $S = \{\vec{x}_1, \vec{x}_2, \dots, \vec{x}_n\}$ be a linearly independent set and their coefficients be selected from $\{0,1\}$. How many elements are there in $\text{Span}(S)$?
- Find the coordinate vector of $\vec{v} = (a,b,c)$ relative to the basis $S = \{(1,1,1), (1,1,0), (1,0,0)\}$
- Show that for any scalar k and any vectors \vec{u} and \vec{v} ,
 $k(\vec{u} - \vec{v}) = k\vec{u} - k\vec{v}$.
- Write the polynomial $s = t^2 + 4t - 3$ over \mathbb{R} as a linear combination of the polynomials $p = t^2 - 2t + 5$, $q = 2t^2 - 3t$ and $r = t + 3$.
- Show that the polynomials $(1-t)^3$, $(1-t)^2$, $1-t$ and 1 generate the space of polynomials of degree ≤ 3 .
- Find condition on a , b , and c so that $(a,b,c) \in \mathbb{R}^3$ belongs to the space generated by $\vec{u} = (2,1,0)$, $\vec{v} = (1,-1,2)$ and $\vec{w} = (0,3,-4)$.

11. Show that the xy -plane $W = \{(a, b, 0)\}$ in \mathbb{R}^3 is generated by $\vec{u} = (1, 2, 0)$ and $\vec{v} = (0, 1, 0)$.
12. Show that the yz -plane $W = \{(0, b, c)\}$ in \mathbb{R}^3 is generated by
- $(0, 1, 1)$ and $(0, 2, -1)$.
 - $(0, 1, 2)$, $(0, 2, 3)$ and $(0, 3, 1)$
13. Show that the vector space V of polynomials over any field K cannot be generated by a finite number of vectors.
14. Find the dimension of the vector space spanned by:
- 3 and -3
 - $(1, -2, 3, -1)$ and $(1, 1, -2, 3)$
 - $t^3 - 2t^2 + 5$ and $t^2 + 3t - 4$
 - $t^3 + 2t^2 + 3t + 1$ and $2t^3 + 4t^2 + 6t + 2$
15. Calculate the distance between
- $A(3, -4, 6)$ and $B(-7, 3, -2)$
 - $A(6, 7, 3)$ and $B(-1, 7, -6)$
 - $A(2, 5, 0)$ and $B(-3, 4, 0)$
16. Give the coordinates of the normalized vector parallel to $\vec{u} = (2, 4, 4)$ and with same direction.
17. Find the value of constant k such that $\vec{a} = (1, 1, -2)$ and $\vec{b} = (5, k, 6)$ will be orthogonal.
18. Find each of the following vector product
- $\vec{i} \times \vec{i}$
 - $\vec{i} \times \vec{j}$
 - $\vec{i} \times \vec{k}$
 - $\vec{j} \times \vec{k}$
 - $\vec{i} \times (\vec{j} \times \vec{k})$
 - $(\vec{i} \times \vec{j}) \times \vec{k}$
19. The vectors \vec{a} and \vec{b} are two sides of a parallelogram in each of the following. Calculate the area of each parallelogram:
- $\vec{a} = 3\vec{i} + \vec{j}, \vec{b} = -3\vec{i} - 2\vec{j} + 2\vec{k}$

$$\text{b) } \vec{a} = 4\vec{i} - \vec{j} + 3\vec{k}, \vec{b} = 8\vec{i} + 3\vec{j} + \vec{k}$$

$$\text{c) } \vec{a} = 2\vec{i} - 2\vec{j} + \vec{k}, \vec{b} = \vec{i} - 5\vec{k}$$

$$\text{d) } \vec{a} = 2\vec{i} + 3\vec{j} - 5\vec{k}, \vec{b} = \vec{i} + 5\vec{j} - 6\vec{k}$$

20. Let $\vec{u} = (2, -1, 3)$, $\vec{v} = (0, 1, 7)$ and $\vec{w} = (1, 4, 5)$. Find:

$$\text{a) } \vec{u} \times (\vec{v} \times \vec{w}) \quad \text{b) } (\vec{u} \times \vec{v}) \times \vec{w} \quad \text{c) } \vec{u} \times (\vec{v} - 2\vec{w})$$

$$\text{d) } (\vec{u} \times \vec{v}) - 2\vec{w} \quad \text{e) } (\vec{u} \times \vec{v}) \times (\vec{v} \times \vec{w}) \quad \text{f) } (\vec{v} \times \vec{w}) \times (\vec{u} \times \vec{v})$$

21. Find the area of the triangle having vertices P , Q and R

$$\text{a) } P(1, 5, -2), Q(0, 0, 0), R(3, 5, 1)$$

$$\text{b) } P(2, 0, -3), Q(1, 4, 5), R(7, 2, 9)$$

22. What is wrong with expression $\vec{u} \times \vec{v} \times \vec{w}$?

23. Find the volume of the parallelepiped with sides \vec{a} , \vec{b} and \vec{c}

$$\text{a) } \vec{a} = (2, -6, 2), \vec{b} = (0, 4, -2), \vec{c} = (2, 2, -4)$$

$$\text{b) } \vec{a} = 3\vec{i} + \vec{j} + 2\vec{k}, \vec{b} = 4\vec{i} + 5\vec{j} + \vec{k}, \vec{c} = \vec{i} + 2\vec{j} + 4\vec{k}$$

24. Consider the parallelepiped with sides

$$\vec{a} = 3\vec{i} + 2\vec{j} + \vec{k}$$

$$\vec{b} = \vec{i} + \vec{j} + 2\vec{k}$$

$$\vec{c} = \vec{i} + 3\vec{j} + 3\vec{k}$$

a) Find the volume.

b) Find the area of the face determined by \vec{a} and \vec{c} .

25. Find the area of the triangle whose vertices are

$$\text{a) } (2, 1, 3), (3, 0, 2), (4, 1, 2) \quad \text{b) } (a, 0, 0), (0, b, 0), (0, 0, c)$$

26. Find the area of the triangle whose vertices are

$$(0, 0, 0), (x_1, y_1, z_1) \text{ and } (x_2, y_2, z_2).$$

27. Find the volume of the tetrahedron whose vertices are

$$(0, 1, 2), (3, 0, 1), (4, 3, 6), (2, 3, 2).$$

28. Calculate the angle between the vectors $\vec{u} = (2, 4, 5)$ and $\vec{v} = (-6, 4, -3)$.
29. A particle is displaced from the point whose position vector is $5\vec{i} - 5\vec{j} - 7\vec{k}$ to the point whose position vector is $6\vec{i} + 2\vec{j} - 2\vec{k}$ under the action of a number of constant forces defined by $10\vec{i} - \vec{j} + 11\vec{k}$, $4\vec{i} + 5\vec{j} + 6\vec{k}$ and $-2\vec{i} + \vec{j} - 8\vec{k}$. Find the work done.
30. Forces of magnitude 3 and 2 in the directions $\vec{i} - 2\vec{j} + 2\vec{k}$ and $2\vec{i} - 3\vec{j} - 6\vec{k}$ respectively act on a particle which is displaced from the point $(2, -1, -3)$ to $(5, -1, 1)$. Find the work done by the forces.

Unit 7

Matrices and Determinant of Order 3

Introductory activity

Given the matrix A such that $A = \begin{pmatrix} a_{11} & a_{12} & a_{13} \\ a_{21} & a_{22} & a_{23} \\ a_{31} & a_{32} & a_{33} \end{pmatrix}$

There is a number **Det A**

$$\det = a_{11}a_{22}a_{33} + a_{21}a_{32}a_{13} + a_{31}a_{23}a_{12} - a_{13}a_{22}a_{31} - a_{23}a_{32}a_{11} - a_{33}a_{21}a_{12}$$

a) Calculate Det Q if

$$Q = \begin{pmatrix} 3 & 2 & 1 \\ 0 & 2 & 5 \\ -2 & 1 & 4 \end{pmatrix}$$

b) Give 3 examples of application of matrices in real life problems.

Objective

By the end of this unit, a student will be able to:

- ⦿ Define and give example of matrix of order three.
- ⦿ Perform different operations on matrices of order three.
- ⦿ Find matrix representation of a linear transformation.
- ⦿ Find the determinant of order three.
- ⦿ Find the inverse of matrix of order three.
- ⦿ Solve system of three linear equations by matrix inverse method.

7.1. Square matrices of order 3

7.1.1. Definitions



Activity 7.1

Consider the transformation

$$f(x, y, z) = (2x + 3y, x - y + 2z, 4x + y - z)$$

Rewrite this transformation in the form

$$\begin{pmatrix} a & b & c \\ d & e & f \\ g & h & i \end{pmatrix} \begin{pmatrix} x \\ y \\ z \end{pmatrix}$$

where a, b, c, d, e, f, g, h and i are constant.

A square matrix is formed by the same number of rows and columns.

The elements of the form (a_{ij}) , where the two subscripts i and j are equal, constitute the **principal diagonal** (or **leading diagonal** or **main diagonal** or **major diagonal** or **primary diagonal**).

The secondary diagonal (or minor diagonal or antidiagonal or counterdiagonal) is formed by the elements with $i + j = n + 1$ where n is the order of the matrix.

Square matrix of order three has the form

$$\begin{pmatrix} a_{11} & a_{12} & a_{13} \\ a_{21} & a_{22} & a_{23} \\ a_{31} & a_{32} & a_{33} \end{pmatrix}$$

Example 7.1

Matrix of order three

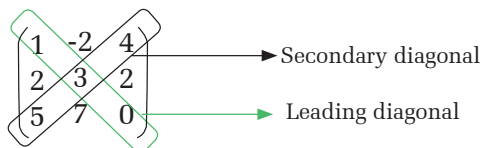

7.1.2. Types of matrices

Upper triangular matrix

In an upper triangular matrix, the elements located below the leading diagonal are zeros.

Example 7.2

$$\begin{pmatrix} 1 & -2 & 4 \\ 0 & 3 & 2 \\ 0 & 0 & 4 \end{pmatrix}$$

Lower triangular matrix

In a lower triangular matrix, the elements above the leading diagonal are zeros.

Example 7.3

$$\begin{pmatrix} 1 & 0 & 0 \\ 2 & 3 & 0 \\ 5 & 7 & 9 \end{pmatrix}$$

Diagonal matrix

In a diagonal matrix, all the elements above and below the leading diagonal are zeros.

Example 7.4

$$\begin{pmatrix} 1 & 0 & 0 \\ 0 & 3 & 0 \\ 0 & 0 & 4 \end{pmatrix}$$

Scalar matrix

A scalar matrix is a diagonal matrix in which the leading diagonal elements are equal.

Example 7.5

$$\begin{pmatrix} 3 & 0 & 0 \\ 0 & 3 & 0 \\ 0 & 0 & 3 \end{pmatrix}$$

Identity matrix or unity matrix

An identity matrix (denoted by I) is a diagonal matrix in which the leading diagonal elements are equal to 1.

Example 7.6

Identity matrix of order three

$$\begin{pmatrix} 1 & 0 & 0 \\ 0 & 1 & 0 \\ 0 & 0 & 1 \end{pmatrix}$$

Equality of matrices

Two matrices are equal if the elements of the two matrices that occupy the same position are equal.

$$\text{If } \begin{pmatrix} a_{11} & a_{12} & a_{13} \\ a_{21} & a_{22} & a_{23} \\ a_{31} & a_{32} & a_{33} \end{pmatrix} = \begin{pmatrix} b_{11} & b_{12} & b_{13} \\ b_{21} & b_{22} & a_{23} \\ b_{31} & b_{32} & b_{33} \end{pmatrix},$$

$$a_{11} = b_{11}, a_{12} = b_{12}, a_{13} = b_{13}$$

$$\text{then } a_{21} = b_{21}, a_{22} = b_{22}, a_{23} = b_{23}$$

$$a_{31} = b_{31}, a_{32} = b_{32}, a_{33} = b_{33}$$

Application Activity 7.1

Give five examples of matrices of order three.

7.1.3. Operations on matrices**Activity 7.2**

Consider the matrices $A = \begin{pmatrix} 2 & -4 & 12 \\ 1 & 0 & -4 \\ 5 & 2 & 3 \end{pmatrix}$, $B = \begin{pmatrix} 1 & 6 & 4 \\ 1 & 7 & 8 \\ 3 & 21 & 3 \end{pmatrix}$ and $C = \begin{pmatrix} 1 & 3 & -1 \\ 0 & 2 & 4 \\ 3 & -2 & 0 \end{pmatrix}$ find;

- $A + 3B$
- $2A - B$
- $A + (-A)$ and give any comment.
- $A + B$ and $B + A$. From the results, give your comment.
- $A + (B + C)$ and $(A + B) + C$. Give your comment.
- Interchange/switch the rows and column of matrix A , B and C .

Adding matrices

Given two matrices of the same dimension, $A = (a_{ij})$ and $B = (b_{ij})$, the matrix sum is defined as: $A + B = (a_{ij} + b_{ij})$. That is, the resultant matrix's elements are obtained by adding the elements of the two matrices that occupy the same position.

$$\text{If } A = \begin{pmatrix} a_{11} & a_{12} & a_{13} \\ a_{21} & a_{22} & a_{23} \\ a_{31} & a_{32} & a_{33} \end{pmatrix} \text{ and } B = \begin{pmatrix} b_{11} & b_{12} & b_{13} \\ b_{21} & b_{22} & b_{23} \\ b_{31} & b_{32} & b_{33} \end{pmatrix}, \text{ then}$$

$$A + B = \begin{pmatrix} a_{11} & a_{12} & a_{13} \\ a_{21} & a_{22} & a_{23} \\ a_{31} & a_{32} & a_{33} \end{pmatrix} + \begin{pmatrix} b_{11} & b_{12} & b_{13} \\ b_{21} & b_{22} & b_{23} \\ b_{31} & b_{32} & b_{33} \end{pmatrix} = \begin{pmatrix} a_{11} + b_{11} & a_{12} + b_{12} & a_{13} + b_{13} \\ a_{21} + b_{21} & a_{22} + b_{22} & a_{23} + b_{23} \\ a_{31} + b_{31} & a_{32} + b_{32} & a_{33} + b_{33} \end{pmatrix}$$

$$A - B = \begin{pmatrix} a_{11} & a_{12} & a_{13} \\ a_{21} & a_{22} & a_{23} \\ a_{31} & a_{32} & a_{33} \end{pmatrix} - \begin{pmatrix} b_{11} & b_{12} & b_{13} \\ b_{21} & b_{22} & b_{23} \\ b_{31} & b_{32} & b_{33} \end{pmatrix} = \begin{pmatrix} a_{11} - b_{11} & a_{12} - b_{12} & a_{13} - b_{13} \\ a_{21} - b_{21} & a_{22} - b_{22} & a_{23} - b_{23} \\ a_{31} - b_{31} & a_{32} - b_{32} & a_{33} - b_{33} \end{pmatrix}$$

Example 7.7

Consider the matrices $A = \begin{pmatrix} 2 & 0 & 1 \\ 3 & 0 & 0 \\ 5 & 1 & 1 \end{pmatrix}$ and $B = \begin{pmatrix} 1 & 0 & 1 \\ 1 & 2 & 1 \\ 1 & 1 & 0 \end{pmatrix}$, find $A + B$ and $A - B$

Solution

$$A + B = \begin{pmatrix} 2+1 & 0+0 & 1+1 \\ 3+1 & 0+2 & 0+1 \\ 5+1 & 1+1 & 1+0 \end{pmatrix} = \begin{pmatrix} 3 & 0 & 2 \\ 4 & 2 & 1 \\ 6 & 2 & 1 \end{pmatrix}$$

$$A - B = \begin{pmatrix} 2-1 & 0-0 & 1-1 \\ 3-1 & 0-2 & 0-1 \\ 5-1 & 1-1 & 1-0 \end{pmatrix} = \begin{pmatrix} 1 & 0 & 0 \\ 2 & -2 & -1 \\ 4 & 0 & 1 \end{pmatrix}$$

Properties

1. Closure

The sum of two matrices of order three is another matrix of order three.

2. Associative

$$A + (B + C) = (A + B) + C$$

3. Additive identity

$A + 0 = A$, where 0 is the zero-matrix of the same dimension.

4. Additive inverse

$$A + (-A) = O$$

The opposite matrix A is -A.

5. Commutative

$$A + B = B + A$$

Scalar multiplication

Given a matrix, $A = (a_{ij})$, and a real number, $k \in IR$, the product of a real number by a matrix is a matrix of the same dimension as A, and each element is multiplied by k.

$$k \cdot A = (k a_{ij})$$

$$\text{If } A = \begin{pmatrix} a_{11} & a_{12} & a_{13} \\ a_{21} & a_{22} & a_{23} \\ a_{31} & a_{32} & a_{33} \end{pmatrix}, \text{ then } kA = \begin{pmatrix} ka_{11} & ka_{12} & ka_{13} \\ ka_{21} & ka_{22} & ka_{23} \\ ka_{31} & ka_{32} & ka_{33} \end{pmatrix}$$

Example 7.8

Consider the matrix $A = \begin{pmatrix} 2 & 0 & 1 \\ 3 & 0 & 0 \\ 5 & 1 & 1 \end{pmatrix}$, find $2A$

Solution

$$2A = 2 \begin{pmatrix} 2 & 0 & 1 \\ 3 & 0 & 0 \\ 5 & 1 & 1 \end{pmatrix} = \begin{pmatrix} 4 & 0 & 2 \\ 6 & 0 & 0 \\ 10 & 2 & 2 \end{pmatrix}$$

Properties

- $\alpha(\beta A) = (\alpha\beta)A$, $A \in M_{m \times n}$, $\alpha, \beta \in IR$
- $\alpha(A + B) = \alpha A + \alpha B$, $A, B \in M_{m \times n}$, $\alpha \in IR$
- $(\alpha + \beta)A = \alpha A + \beta A$, $A \in M_{m \times n}$, $\alpha, \beta \in IR$
- $1A = A$, $A \in M_{m \times n}$

Application Activity 7.2

$$\text{If } A = \begin{pmatrix} 1 & -2 & 6 \\ 2 & 2 & -5 \\ 0 & 4 & 8 \end{pmatrix}, B = \begin{pmatrix} 0 & 8 & 9 \\ 14 & 4 & 6 \\ 0 & 6 & 7 \end{pmatrix} \text{ and } C = \begin{pmatrix} 13 & -2 & 0 \\ 10 & 0 & 3 \\ 9 & 1 & -5 \end{pmatrix}.$$

Evaluate

1. $A - B$
2. $A + B - 2C$
3. $2A - B + C$

Transpose matrix**Activity 7.3**

$$\text{Consider the matrices } A = \begin{pmatrix} 1 & 3 & 1 \\ 1 & -2 & 2 \\ 3 & -2 & 0 \end{pmatrix} \text{ and } B = \begin{pmatrix} 12 & 3 & -1 \\ 3 & -2 & 0 \\ -4 & -1 & 0 \end{pmatrix}$$

1. Interchange/switch the rows and columns of matrix A and B
2. Add two matrices obtained in 1
3. Add A and B
4. Interchange/switch the rows and columns of matrix obtained in 3
5. What can you say about result in 2 and 4?
6. Interchange/switch the rows and columns of matrix A twice. What can you conclude?

Given matrix A , the transpose of matrix A , noted A' , is another matrix where the elements in the columns and rows have switched. In other words, the rows become the columns and the columns become the rows.

$$\text{If } A = \begin{pmatrix} a_{11} & a_{12} & a_{13} \\ a_{21} & a_{22} & a_{23} \\ a_{31} & a_{32} & a_{33} \end{pmatrix}, \text{ then } A' = \begin{pmatrix} a_{11} & a_{21} & a_{31} \\ a_{12} & a_{22} & a_{32} \\ a_{13} & a_{23} & a_{33} \end{pmatrix}$$

Example 7.9

$$A = \begin{pmatrix} 1 & 3 & 6 \\ 0 & 2 & 0 \\ 3 & 5 & 8 \end{pmatrix} \qquad A' = \begin{pmatrix} 1 & 0 & 3 \\ 3 & 2 & 5 \\ 6 & 0 & 8 \end{pmatrix}$$

Properties of transpose of matrices

Let A, B be matrices of order three

- $(A^t)^t = A$
- $(A + B)^t = A^t + B^t$
- $(\alpha \times A)^t = \alpha \times A^t, \alpha \in \mathbb{R}$

Application Activity 7.3

Consider matrices $A = \begin{pmatrix} 0 & 4 & 2 \\ 1 & 3 & 6 \\ 3 & -2 & 8 \end{pmatrix}$ and $B = \begin{pmatrix} 1 & 2 & 1 \\ -4 & 0 & 3 \\ 6 & 2 & 5 \end{pmatrix}$.

Evaluate

- $(A+B)^t$
- $3A^t + B$
- $(-3B+4A)^t$
- Find the value of x in $M = \begin{pmatrix} 1 & 2 & x^2 \\ 4 & 1 & 0 \\ 1 & x+3 & 8 \end{pmatrix}$ if $M^t = \begin{pmatrix} 1 & 4 & 1 \\ 2 & 1 & 1 \\ 4 & 0 & 8 \end{pmatrix}$

Multiplying matrices

Activity 7.4



Consider the matrices $A = \begin{pmatrix} -1 & 1 & 1 \\ 2 & 2 & 5 \\ 0 & 3 & 4 \end{pmatrix}$ and $B = \begin{pmatrix} 2 & 1 & -1 \\ 3 & 2 & 3 \\ -1 & 6 & 4 \end{pmatrix}$
find $A \times B$

Hint:

$$A \times B = \begin{pmatrix} a_{11} & a_{12} & a_{13} \\ a_{21} & a_{22} & a_{23} \\ a_{31} & a_{32} & a_{33} \end{pmatrix} \times \begin{pmatrix} b_{11} & b_{12} & b_{13} \\ b_{21} & b_{22} & b_{23} \\ b_{31} & b_{32} & b_{33} \end{pmatrix}$$

$$= \begin{pmatrix} a_{11}b_{11} + a_{12}b_{21} + a_{13}b_{31} & a_{11}b_{12} + a_{12}b_{22} + a_{13}b_{32} & a_{11}b_{13} + a_{12}b_{23} + a_{13}b_{33} \\ a_{21}b_{11} + a_{22}b_{21} + a_{23}b_{31} & a_{21}b_{12} + a_{22}b_{22} + a_{23}b_{32} & a_{21}b_{13} + a_{22}b_{23} + a_{23}b_{33} \\ a_{31}b_{11} + a_{32}b_{21} + a_{33}b_{31} & a_{31}b_{12} + a_{32}b_{22} + a_{33}b_{32} & a_{31}b_{13} + a_{32}b_{23} + a_{33}b_{33} \end{pmatrix}$$

Two matrices A and B can be multiplied together if and only if the number of columns of A is equal to the number of rows of B .

$$M_{m \times n} \times M_{n \times p} = M_{m \times p}$$

The element, c_{ij} , of the product matrix is obtained by multiplying every element in row i of matrix A by each element of column j of matrix B and then adding them together. This multiplication is called **ROCO** (row, column).

$$\text{If } A = \begin{pmatrix} a_{11} & a_{12} & a_{13} \\ a_{21} & a_{22} & a_{23} \\ a_{31} & a_{32} & a_{33} \end{pmatrix} \text{ and } B = \begin{pmatrix} b_{11} & b_{12} & b_{13} \\ b_{21} & b_{22} & b_{23} \\ b_{31} & b_{32} & b_{33} \end{pmatrix}, \text{ then}$$

$$\begin{aligned} A \times B &= \begin{pmatrix} a_{11} & a_{12} & a_{13} \\ a_{21} & a_{22} & a_{23} \\ a_{31} & a_{32} & a_{33} \end{pmatrix} \times \begin{pmatrix} b_{11} & b_{12} & b_{13} \\ b_{21} & b_{22} & b_{23} \\ b_{31} & b_{32} & b_{33} \end{pmatrix} \\ &= \begin{pmatrix} a_{11}b_{11} + a_{12}b_{21} + a_{13}b_{31} & a_{11}b_{12} + a_{12}b_{22} + a_{13}b_{32} & a_{11}b_{13} + a_{12}b_{23} + a_{13}b_{33} \\ a_{21}b_{11} + a_{22}b_{21} + a_{23}b_{31} & a_{21}b_{12} + a_{22}b_{22} + a_{23}b_{32} & a_{21}b_{13} + a_{22}b_{23} + a_{23}b_{33} \\ a_{31}b_{11} + a_{32}b_{21} + a_{33}b_{31} & a_{31}b_{12} + a_{32}b_{22} + a_{33}b_{32} & a_{31}b_{13} + a_{32}b_{23} + a_{33}b_{33} \end{pmatrix} \end{aligned}$$

Example 7.10

Consider matrices $A = \begin{pmatrix} 2 & 0 & 1 \\ 3 & 0 & 0 \\ 5 & 1 & 1 \end{pmatrix}$ and $B = \begin{pmatrix} 1 & 0 & 1 \\ 1 & 2 & 1 \\ 1 & 1 & 0 \end{pmatrix}$, find $A \times B$

Solution

$$\begin{aligned} A \times B &= \begin{pmatrix} 2 & 0 & 1 \\ 3 & 0 & 0 \\ 5 & 1 & 1 \end{pmatrix} \times \begin{pmatrix} 1 & 0 & 1 \\ 1 & 2 & 1 \\ 1 & 1 & 0 \end{pmatrix} \\ &= \begin{pmatrix} 2 \times 1 + 0 \times 1 + 1 \times 1 & 2 \times 0 + 0 \times 2 + 1 \times 1 & 2 \times 1 + 0 \times 1 + 1 \times 0 \\ 3 \times 1 + 0 \times 1 + 0 \times 1 & 3 \times 0 + 0 \times 2 + 0 \times 1 & 3 \times 1 + 0 \times 1 + 0 \times 0 \\ 5 \times 1 + 1 \times 1 + 1 \times 1 & 5 \times 0 + 1 \times 2 + 1 \times 1 & 5 \times 1 + 1 \times 1 + 1 \times 0 \end{pmatrix} \\ &= \begin{pmatrix} 2+1 & 0+1 & 2+0 \\ 3+0 & 0 & 3+0 \\ 5+1+1 & 0+2+1 & 5+1+0 \end{pmatrix} \\ &= \begin{pmatrix} 3 & 1 & 2 \\ 3 & 0 & 3 \\ 7 & 3 & 6 \end{pmatrix} \end{aligned}$$

Application Activity 7.4

$$\text{If } A = \begin{pmatrix} 1 & -2 & 6 \\ 2 & 2 & -5 \\ 0 & 4 & 8 \end{pmatrix}, B = \begin{pmatrix} 0 & 8 & 9 \\ 14 & 4 & 6 \\ 0 & 6 & 7 \end{pmatrix} \text{ and } C = \begin{pmatrix} 13 & -2 & 0 \\ 10 & 0 & 3 \\ 9 & 1 & -5 \end{pmatrix}.$$

Evaluate

1. $A \times B$

2. $A \times C$

3. $B \times C$

Properties of matrices multiplication

Activity 7.5



$$\text{Consider the matrices } A = \begin{pmatrix} 3 & 0 & 1 \\ 0 & -1 & 1 \\ -2 & 3 & 2 \end{pmatrix} \text{ and } B = \begin{pmatrix} 0 & 1 & -1 \\ 1 & 1 & -2 \\ -1 & 0 & 1 \end{pmatrix}$$

$$\text{and } C = \begin{pmatrix} 1 & 1 & -1 \\ 1 & -2 & 1 \\ -1 & 1 & 0 \end{pmatrix} \text{ find;}$$

1. $A \times B$ and $B \times A$

2. $(A \times B)^t$ and $B^t \times A^t$

3. $A \times (B \times C)$ and $(A \times B) \times C$

4. $A \times (B + C)$ and $A \times B + A \times C$

Comment on your results.

Let A, B, C be matrices of order three

1. Associative

$$A \times (B \times C) = (A \times B) \times C$$

2. Multiplicative identity

$A \times I = A$, where I is the identity matrix with the same order as matrix A .

3. Not commutative

$$A \times B \neq B \times A$$

4. Distributive

$$A \times (B + C) = A \times B + A \times C$$

5. $(A \times B)^t = B^t \times A^t$

Example 7.11

Given the matrices:

$$A = \begin{pmatrix} 2 & 0 & 1 \\ 3 & 0 & 0 \\ 5 & 1 & 1 \end{pmatrix} \text{ and } B = \begin{pmatrix} 1 & 0 & 1 \\ 1 & 2 & 1 \\ 1 & 1 & 0 \end{pmatrix}$$

Find

- The product $A \times B$
- The product $B \times A$

Solution

a)

$$\begin{aligned} A \times B &= \begin{pmatrix} 2 & 0 & 1 \\ 3 & 0 & 0 \\ 5 & 1 & 1 \end{pmatrix} \begin{pmatrix} 1 & 0 & 1 \\ 1 & 2 & 1 \\ 1 & 1 & 0 \end{pmatrix} \\ &= \begin{pmatrix} 2 \times 1 + 0 \times 1 + 1 \times 1 & 2 \times 0 + 0 \times 2 + 1 \times 1 & 2 \times 1 + 0 \times 1 + 1 \times 0 \\ 3 \times 1 + 0 \times 1 + 0 \times 1 & 3 \times 0 + 0 \times 2 + 0 \times 1 & 3 \times 1 + 0 \times 1 + 0 \times 0 \\ 5 \times 1 + 1 \times 1 + 1 \times 1 & 5 \times 0 + 1 \times 2 + 1 \times 1 & 5 \times 1 + 1 \times 1 + 1 \times 0 \end{pmatrix} \\ &= \begin{pmatrix} 3 & 1 & 2 \\ 3 & 0 & 3 \\ 7 & 3 & 6 \end{pmatrix} \end{aligned}$$

b)

$$\begin{aligned} B \times A &= \begin{pmatrix} 1 & 0 & 1 \\ 1 & 2 & 1 \\ 1 & 1 & 0 \end{pmatrix} \begin{pmatrix} 2 & 0 & 1 \\ 3 & 0 & 0 \\ 5 & 1 & 1 \end{pmatrix} \\ &= \begin{pmatrix} 1 \times 2 + 0 \times 3 + 1 \times 5 & 1 \times 0 + 0 \times 0 + 1 \times 1 & 1 \times 1 + 0 \times 0 + 1 \times 1 \\ 1 \times 2 + 2 \times 3 + 1 \times 5 & 1 \times 0 + 2 \times 0 + 1 \times 1 & 1 \times 1 + 2 \times 0 + 1 \times 1 \\ 1 \times 2 + 1 \times 3 + 0 \times 5 & 1 \times 0 + 1 \times 0 + 0 \times 1 & 1 \times 1 + 1 \times 0 + 0 \times 1 \end{pmatrix} \\ &= \begin{pmatrix} 7 & 1 & 2 \\ 13 & 1 & 2 \\ 5 & 0 & 1 \end{pmatrix} \end{aligned}$$

c)

$$\begin{aligned}
 AB &= \begin{pmatrix} 1 & -1 & 1 \\ -3 & 2 & -1 \\ -2 & 1 & 0 \end{pmatrix} \begin{pmatrix} 1 & 2 & 3 \\ 2 & 4 & 6 \\ 1 & 2 & 3 \end{pmatrix} \\
 &= \begin{pmatrix} 1-2+1 & 2-4+2 & 3-6+3 \\ -3+4-1 & -6+8-2 & -9+12-3 \\ -2+2+0 & -4+4+0 & -6+6+0 \end{pmatrix} \\
 &= \begin{pmatrix} 0 & 0 & 0 \\ 0 & 0 & 0 \\ 0 & 0 & 0 \end{pmatrix}
 \end{aligned}$$

Example 7.12

Given matrices $A = \begin{pmatrix} 1 & -1 & 1 \\ -3 & 2 & -1 \\ -2 & 1 & 0 \end{pmatrix}$ and $B = \begin{pmatrix} 1 & 2 & 3 \\ 2 & 4 & 6 \\ 1 & 2 & 3 \end{pmatrix}$. Find the product AB . What is your observation?

Solution

Observation: If $AB = 0$, it does not necessarily follow that $A = 0$ or $B = 0$.

Example 7.13

Given matrices $A = \begin{pmatrix} 1 & 0 & 0 \\ 0 & 1 & 0 \\ 1 & 0 & 2 \end{pmatrix}$ and $B = \begin{pmatrix} 2 & 4 & 0 \\ 3 & 1 & 0 \\ -1 & -4 & 1 \end{pmatrix}$. Find the product AB and BA . What is your observation?

Solution

$$\begin{aligned}
 AB &= \begin{pmatrix} 1 & 0 & 0 \\ 0 & 1 & 0 \\ 1 & 0 & 2 \end{pmatrix} \begin{pmatrix} 2 & 4 & 0 \\ 3 & 1 & 0 \\ -1 & -4 & 1 \end{pmatrix} = \begin{pmatrix} 2 & 4 & 0 \\ 3 & 1 & 0 \\ 0 & -4 & 2 \end{pmatrix} \\
 BA &= \begin{pmatrix} 2 & 4 & 0 \\ 3 & 1 & 0 \\ -1 & -4 & 1 \end{pmatrix} \begin{pmatrix} 1 & 0 & 0 \\ 0 & 1 & 0 \\ 1 & 0 & 2 \end{pmatrix} = \begin{pmatrix} 2 & 4 & 0 \\ 3 & 1 & 0 \\ 0 & -4 & 2 \end{pmatrix} \\
 \Rightarrow AB &= BA
 \end{aligned}$$

Observation: The given matrices commute in multiplication.



Notice

⊙ If $AB = 0$, it does not necessarily follow that $A = 0$ or $B = 0$.

⊙ Commuting matrices in multiplication

In general, the multiplication of matrices is not commutative, i.e., $AB \neq BA$, but we can have the case where two matrices A and B satisfy $AB = BA$. In this case, A and B are said to be commuting.

Trace of matrix

The sum of the entries on the leading diagonal of a square matrix, A, is known as the trace of that matrix, denoted $tr(A)$.

Example 7.14

1. Trace of $\begin{pmatrix} 1 & -2 & 4 \\ 2 & 3 & 2 \\ 5 & 7 & 2 \end{pmatrix} = 1 + 3 + 2 = 6$

2. Trace of $\begin{pmatrix} 1 & 2 \\ 3 & 1 \end{pmatrix} = 1 + 1 = 2$

Properties of trace of matrix

1. $tr(A + B) = tr(A) + tr(B)$

2. $tr(\alpha A) = \alpha tr(A)$

3. $tr(A) = tr(A)^t$

4. $tr(AB) = tr(BA)$

5. $tr(ABC) = tr(BCA) = tr(CAB)$, cyclic property.

6. $tr(ABC) \neq tr(ACB)$, arbitrary permutations are not allowed.

Application Activity 7.5

1. Consider the matrices $A = \begin{pmatrix} 1 & 0 & 1 \\ 1 & -1 & 1 \\ 0 & 0 & 0 \end{pmatrix}$ $B = \begin{pmatrix} -2 & 0 & 1 \\ 1 & 0 & 2 \\ -1 & 0 & 1 \end{pmatrix}$ and $C = \begin{pmatrix} 1 & 0 & -1 \\ -2 & 2 & 0 \\ -1 & 1 & 0 \end{pmatrix}$ find

- a) $A \times B$ and $B \times A$
 b) $A \times (B \times C)$ and $(A \times B) \times C$
 c) $A \times (B + C)$ and $A \times B + A \times C$
 d) $tr(AB)$

2. Consider the matrix $A = \begin{pmatrix} \cos \theta & 0 & \sin \theta \\ 0 & 1 & 0 \\ -\sin \theta & 0 & \cos \theta \end{pmatrix}$, find $A \times A^t$

1.2. Matrix of linear transformation in 3 dimensions

Activity 7.6



Let $f(x, y, z) = (x + z, y - z, 2x)$ and the standard basis of \mathbb{R}^3 is $\{\vec{e}_1 = (1, 0, 0), \vec{e}_2 = (0, 1, 0), \vec{e}_3 = (0, 0, 1)\}$. Find:

1. $f(\vec{e}_1)$
2. $f(\vec{e}_2)$
3. $f(\vec{e}_3)$
4. Form matrix whose j^{th} column is $f(\vec{e}_j)$, $j = 1, 2, 3$

Every linear transformation $f: \mathbb{R}^3 \rightarrow \mathbb{R}^3$ can be identified with a matrix of order three, $[f]_e = (a_{ij})$, whose j^{th} column is $f(\vec{e}_j)$ where $\{\vec{e}_j\}$, $j = 1, 2, 3$ is the standard basis of \mathbb{R}^3 . The matrix $[f]_e$ is called matrix representation of f relative to the standard basis $\{\vec{e}_j\}$.

Example 7.15

Find the matrix of f relative to the standard basis if

$$f: \mathbb{R}^3 \rightarrow \mathbb{R}^3$$

$$f(x, y, z) = (4x - 2z, 2x + y, z + y)$$

Solution

The standard basis of \mathbb{R}^3 is $\{\vec{e}_1 = (1, 0, 0), \vec{e}_2 = (0, 1, 0), \vec{e}_3 = (0, 0, 1)\}$

$$f(\vec{e}_1) = (4, 2, 0) \quad f(\vec{e}_2) = (0, 1, 1) \quad f(\vec{e}_3) = (-2, 0, 1)$$

Then the matrix of f relative to the standard basis is

$$[f]_e = \begin{pmatrix} 4 & 0 & -2 \\ 2 & 1 & 0 \\ 0 & 1 & 1 \end{pmatrix}$$

What is the procedure if the given basis is not standard? The following is the general method:

To find the matrix of a linear mapping f relative to any basis $\{\vec{e}_1, \vec{e}_2, \vec{e}_3\}$, we follow the following steps:

1. Find $f(\vec{e}_j)$, $j = 1, 2, 3$.
2. Equate $f(\vec{e}_j)$ to $\vec{e}_i a_{ij}$ to find the values of a_{ij} .
3. The matrix of f is $[f]_e = (a_{ij})$ where $\begin{cases} i = \text{number of row} \\ j = \text{number of column} \end{cases}$

Example 7.16

Consider the following linear mapping defined on \mathbb{R}^3 by $f(x, y, z) = (4x - 2z, 2x + y, z + y)$. Calculate its matrix relative to the basis $\{\vec{e}_1 = (1, 1, 1), \vec{e}_2 = (-1, 0, 1), \vec{e}_3 = (0, 1, 1)\}$.

Solution

$$f(\vec{e}_1) = (4 - 2, 2 + 1, 1 + 1) = (2, 3, 2)$$

$$f(\vec{e}_2) = (-4 - 2, -2 + 0, 1 + 0) = (-6, -2, 1)$$

$$f(\vec{e}_3) = (0 - 2, 0 + 1, 1 + 1) = (-2, 1, 2)$$

$$f(\vec{e}_j) = \vec{e}_i a_{ij}$$

$$\odot f(\vec{e}_1) = \vec{e}_i a_{i1}$$

$$\begin{pmatrix} 2 \\ 3 \\ 2 \end{pmatrix} = \begin{pmatrix} 1 \\ 1 \\ 1 \end{pmatrix} a_{11} + \begin{pmatrix} -1 \\ 0 \\ 1 \end{pmatrix} a_{21} + \begin{pmatrix} 0 \\ 1 \\ 1 \end{pmatrix} a_{31}$$

$$\begin{pmatrix} 2 \\ 3 \\ 2 \end{pmatrix} = \begin{pmatrix} a_{11} \\ a_{11} \\ a_{11} \end{pmatrix} + \begin{pmatrix} -a_{21} \\ 0 \\ a_{21} \end{pmatrix} + \begin{pmatrix} 0 \\ a_{31} \\ a_{31} \end{pmatrix}$$

$$\begin{cases} a_{11} - a_{21} = 2 \\ a_{11} + a_{31} = 3 \\ a_{11} + a_{21} + a_{31} = 2 \end{cases} \quad \begin{cases} a_{11} = 1 \\ a_{21} = -1 \\ a_{31} = 2 \end{cases}$$

$$\odot f(\vec{e}_2) = \vec{e}_i a_{i2}$$

$$\begin{pmatrix} -6 \\ -2 \\ 1 \end{pmatrix} = \begin{pmatrix} 1 \\ 1 \\ 1 \end{pmatrix} a_{12} + \begin{pmatrix} -1 \\ 0 \\ 1 \end{pmatrix} a_{22} + \begin{pmatrix} 0 \\ 1 \\ 1 \end{pmatrix} a_{32}$$

$$\begin{pmatrix} -6 \\ -2 \\ 1 \end{pmatrix} = \begin{pmatrix} a_{12} \\ a_{12} \\ a_{12} \end{pmatrix} + \begin{pmatrix} -a_{22} \\ 0 \\ a_{22} \end{pmatrix} + \begin{pmatrix} 0 \\ a_{32} \\ a_{32} \end{pmatrix}$$

$$\begin{cases} a_{12} - a_{22} = -6 \\ a_{12} + a_{32} = -2 \\ a_{12} + a_{22} + a_{32} = 1 \end{cases} \quad \begin{cases} a_{12} = -3 \\ a_{22} = 3 \\ a_{32} = 1 \end{cases}$$

$$\odot f(\vec{e}_3) = \vec{e}_i a_{i3}$$

$$\begin{pmatrix} -2 \\ 1 \\ 2 \end{pmatrix} = \begin{pmatrix} 1 \\ 1 \\ 1 \end{pmatrix} a_{13} + \begin{pmatrix} -1 \\ 0 \\ 1 \end{pmatrix} a_{23} + \begin{pmatrix} 0 \\ 1 \\ 1 \end{pmatrix} a_{33}$$

$$\begin{pmatrix} -2 \\ 1 \\ 2 \end{pmatrix} = \begin{pmatrix} a_{13} \\ a_{13} \\ a_{13} \end{pmatrix} + \begin{pmatrix} -a_{23} \\ 0 \\ a_{23} \end{pmatrix} + \begin{pmatrix} 0 \\ a_{33} \\ a_{33} \end{pmatrix}$$

$$\begin{cases} a_{13} - a_{23} = -2 \\ a_{13} + a_{33} = 1 \\ a_{13} + a_{23} + a_{33} = 2 \end{cases} \quad \begin{cases} a_{13} = -1 \\ a_{23} = 1 \\ a_{33} = 2 \end{cases}$$

The matrix of f is given by $[f]_e = (a_{ij}) = \begin{pmatrix} a_{11} & a_{12} & a_{13} \\ a_{21} & a_{22} & a_{23} \\ a_{31} & a_{32} & a_{33} \end{pmatrix}$, therefore,

$$[f]_e = \begin{pmatrix} 1 & -3 & -1 \\ -1 & 3 & 1 \\ 2 & 1 & 2 \end{pmatrix}$$

Theorems

\odot Let $\{\vec{e}_1, \vec{e}_2, \vec{e}_3\}$ be a basis of E and let f be any operator on E . Then, for any vector $\vec{v} \in E$, $[f]_e \cdot [\vec{v}]_e = [f(\vec{v})]_e$.

That is, if we multiply the coordinate vector of \vec{v} by matrix representation of f , we obtain the coordinate vector of $f(\vec{v})$.

\odot Let $\{\vec{e}_i\}, \{\vec{f}_i\}$ and $\{\vec{g}_i\}$ be bases of E, U and V respectively.

Let $f: E \rightarrow U$ and $g: U \rightarrow V$ be linear mappings. Then $[g \circ f]_{e_i}^{s_i} = [g]_{f_i}^{s_i} [f]_{e_i}^{f_i}$. That is, relative to the appropriate bases, the matrix representation of the composition of two linear mappings is equal to the product of the matrix representations of the individual mappings.

- ⊙ For any $f, g \in L(E)$ and any scalar $\alpha \in K$, $[g + f]_e = [g]_e + [f]_e$ and $[\alpha g]_e = \alpha [g]_e$.

Example 7.17

Matrices representation of linear transformation f and g are

$$A = \begin{pmatrix} 0 & -4 & 3 \\ -1 & 1 & 0 \\ -1 & 4 & -2 \end{pmatrix} \text{ and } B = \begin{pmatrix} 3 & 0 & 4 \\ 1 & 5 & -1 \\ 2 & 1 & 2 \end{pmatrix} \text{ respectively.}$$

Find matrix representation of

- a) $4f$ b) $2f + 3g$ c) $f \circ g$

Solution

$$\text{a) } [4f] = 4 \begin{pmatrix} 0 & -4 & 3 \\ -1 & 1 & 0 \\ -1 & 4 & -2 \end{pmatrix} = \begin{pmatrix} 0 & -16 & 12 \\ -4 & 4 & 0 \\ -4 & 16 & -8 \end{pmatrix}$$

$$\text{b) } [2f + 3g] = 2 \begin{pmatrix} 0 & -4 & 3 \\ -1 & 1 & 0 \\ -1 & 4 & -2 \end{pmatrix} + 3 \begin{pmatrix} 3 & 0 & 4 \\ 1 & 5 & -1 \\ 2 & 1 & 2 \end{pmatrix} = \begin{pmatrix} 9 & -8 & 18 \\ 1 & 17 & -3 \\ 4 & 11 & 2 \end{pmatrix}$$

$$\text{c) } [f \circ g] = \begin{pmatrix} 0 & -4 & 3 \\ -1 & 1 & 0 \\ -1 & 4 & -2 \end{pmatrix} \begin{pmatrix} 3 & 0 & 4 \\ 1 & 5 & -1 \\ 2 & 1 & 2 \end{pmatrix} = \begin{pmatrix} 2 & -17 & 10 \\ -2 & 5 & -5 \\ -3 & 18 & -12 \end{pmatrix}$$

Application Activity 7.6

1. Find matrix representation of the transformation

$$f: \mathbb{R}^3 \rightarrow \mathbb{R}^3$$

$$f(x, y, z) = (3x + 2y, 2z - y, z - x)$$

- a) Relative to the standard basis of \mathbb{R}^3

- b) Relative to the basis $\{\vec{e}_1 = (1, 1, 1), \vec{e}_2 = (-1, 0, 1), \vec{e}_3 = (0, 1, 1)\}$

2. Matrices representation of linear transformation f and g are

$$A = \begin{pmatrix} 3 & 4 & 1 \\ -1 & 2 & 0 \\ 4 & -5 & -3 \end{pmatrix} \text{ and } B = \begin{pmatrix} 2 & 3 & 2 \\ -1 & 0 & 3 \\ 1 & 0 & 2 \end{pmatrix} \text{ respectively.}$$

Find matrix representation of

- a) $4f - 5g$ b) $f \circ g$ c) $g \circ f$

7.3. Determinants of order 3

7.3.1. Determinant of order 3



Activity 7.7

Evaluate the following operations by considering the direction of arrows

1.
$$\begin{vmatrix} 1 & -4 & 2 \\ 3 & 6 & 1 \\ 5 & 0 & 1 \end{vmatrix}$$

2.
$$\begin{vmatrix} 10 & 2 & 4 \\ -6 & 5 & 2 \\ 0 & 3 & 1 \end{vmatrix}$$

Consider an arbitrary 3x3 matrix, $A = \begin{pmatrix} a_{11} & a_{12} & a_{13} \\ a_{21} & a_{22} & a_{23} \\ a_{31} & a_{32} & a_{33} \end{pmatrix}$.

The determinant of A noted $\det A = |A| = \begin{vmatrix} a_{11} & a_{12} & a_{13} \\ a_{21} & a_{22} & a_{23} \\ a_{31} & a_{32} & a_{33} \end{vmatrix}$ is calculated by rule of SARRUS

The terms with a **positive sign** are formed by the elements of the **principal diagonal** and those of the **parallel diagonals** with its corresponding **opposite vertex**.

The terms with a **negative sign** are formed by the elements of the **secondary diagonal** and those of the **parallel diagonals** with its corresponding **opposite vertex**.

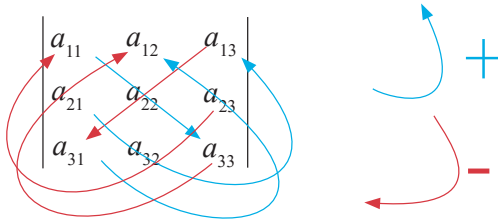

$$\det A = a_{11}a_{22}a_{33} + a_{21}a_{32}a_{13} + a_{31}a_{23}a_{12} - a_{13}a_{22}a_{31} - a_{23}a_{32}a_{11} - a_{33}a_{21}a_{12}$$

Or we can work out as follows:

To calculate the 3x3 determinant, we rewrite the first two rows below the determinant (or first two columns to the right of the determinant).

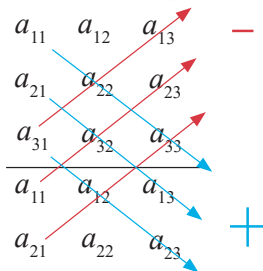

$$\det A = a_{11}a_{22}a_{33} + a_{21}a_{32}a_{13} + a_{31}a_{12}a_{23} - a_{31}a_{22}a_{13} - a_{11}a_{32}a_{23} - a_{21}a_{12}a_{33}$$

Or

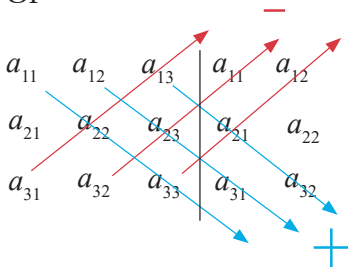

$$\det A = a_{11}a_{22}a_{33} + a_{12}a_{23}a_{31} + a_{13}a_{21}a_{32} - a_{31}a_{22}a_{13} - a_{32}a_{23}a_{11} - a_{33}a_{21}a_{12}$$

As multiplication of real numbers is commutative, the three are the same.

Example 7.18

$$\begin{vmatrix} 3 & 2 & 1 \\ 0 & 2 & -5 \\ -2 & 1 & 4 \end{vmatrix} = 3 \times 2 \times 4 + 0 \times 1 \times 1 + (-2) \times (-5) \times 2 - 1 \times 2 \times (-2) - (-5) \times 1 \times 3 - 4 \times 0 \times 2 \\
 = 24 + 0 + 20 + 4 + 15 - 0 \\
 = 63$$

General rule for $n \times n$ matrices (minor and cofactor)

General method of finding the determinant of matrix with $n \times n$ dimension (2×2 , 3×3 , 4×4 , 5×5 , ...) is the use of cofactors.

Minor

The minor of an element a_{ij} , is the determinant of the matrix remained after we delete the i^{th} row and the j^{th} column

Example 7.19

Consider the matrix $\begin{pmatrix} 1 & 2 & 1 \\ 2 & 5 & 4 \\ 3 & 6 & 2 \end{pmatrix}$ the minor of 5 is $\begin{vmatrix} 1 & 1 \\ 3 & 2 \end{vmatrix}$

Cofactor

The cofactor of the element a_{ij} is its minor prefixing:

The + sign if $i+j$ is **even**.

The - sign if $i+j$ is **odd**.

$$\begin{vmatrix} 1 & 2 & 1 \\ [2] & 5 & 4 \\ 3 & 6 & 2 \end{vmatrix} \rightarrow - \begin{vmatrix} 2 & 1 \\ 6 & 2 \end{vmatrix}$$

The value of a determinant is equal to the sum of the products of the elements of a line (row or column) by its corresponding cofactors:

$$|A| = \begin{vmatrix} a_{11} & a_{12} & a_{13} \\ a_{21} & a_{22} & a_{23} \\ a_{31} & a_{32} & a_{33} \end{vmatrix} = a_{11} \begin{vmatrix} a_{22} & a_{23} \\ a_{32} & a_{33} \end{vmatrix} - a_{12} \begin{vmatrix} a_{21} & a_{23} \\ a_{31} & a_{33} \end{vmatrix} + a_{13} \begin{vmatrix} a_{21} & a_{22} \\ a_{31} & a_{32} \end{vmatrix}$$

Example 7.20

$$\begin{vmatrix} 3 & 2 & 1 \\ 0 & 2 & -5 \\ -2 & 1 & 4 \end{vmatrix} = 3 \begin{vmatrix} 2 & -5 \\ 1 & 4 \end{vmatrix} - 2 \begin{vmatrix} 0 & -5 \\ -2 & 4 \end{vmatrix} + 1 \begin{vmatrix} 0 & 2 \\ -2 & 1 \end{vmatrix}$$

$$= 3(8+5) - 2(0-10) + 1(0+4)$$

$$= 39 + 20 + 4$$

$$= 63$$

Note that we choose only one line (row or column).

Application Activity 7.7

Find the determinants of the following matrices:

1. $A = \begin{pmatrix} 1 & 3 & 1 \\ -4 & 5 & -2 \\ -3 & 1 & 3 \end{pmatrix}$

2. $B = \begin{pmatrix} 1 & 4 & -2 \\ 0 & 1 & 2 \\ 1 & 2 & 4 \end{pmatrix}$

3. $C = \begin{pmatrix} 1 & 4 & 2 \\ -2 & 0 & 1 \\ -1 & 3 & 0 \end{pmatrix}$

Properties of a determinant**Activity 7.8**

Consider the matrices $A = \begin{pmatrix} 1 & 0 & 1 \\ 1 & -1 & 1 \\ 0 & 0 & 0 \end{pmatrix}$, $B = \begin{pmatrix} -2 & 1 & -1 \\ 1 & 3 & 4 \\ -1 & 4 & 3 \end{pmatrix}$,

$C = \begin{pmatrix} 1 & 0 & -1 \\ 0 & 2 & 1 \\ 0 & 0 & 3 \end{pmatrix}$ and $D = \begin{pmatrix} 1 & 3 & -1 \\ -1 & 2 & 2 \\ 0 & 1 & -1 \end{pmatrix}$ find:

- $|A|$ and $|B|$
- $|C \cdot D|$ and $|C| \cdot |D|$. What can you conclude?
- Product of the leading diagonal elements of matrix C and $|C|$. What can you conclude?

1. Matrix A and its transpose A^t have the same determinant.

$$|A^t| = |A|$$

Example 7.21

$$A = \begin{vmatrix} 2 & 3 & 0 \\ 3 & 2 & 7 \\ 2 & 1 & 6 \end{vmatrix}, \quad A^t = \begin{vmatrix} 2 & 3 & 2 \\ 3 & 2 & 1 \\ 0 & 7 & 6 \end{vmatrix}, \quad |A| = |A^t| = -2$$

2. $|A| = 0$ if:

⊙ It has two equal lines

Example 7.22

$$|A| = \begin{vmatrix} 2 & 3 & 2 \\ 3 & 2 & 3 \\ 2 & 3 & 2 \end{vmatrix} = 0$$

⊙ All elements of a line are zero.

Example 7.23

$$|A| = \begin{vmatrix} 2 & 3 & 2 \\ 3 & 2 & 3 \\ 0 & 0 & 0 \end{vmatrix} = 0$$

⊙ The elements of a line are a linear combination of the others.

Example 7.24

$$|A| = \begin{vmatrix} 2 & 3 & 2 \\ 1 & 2 & 4 \\ 3 & 5 & 6 \end{vmatrix} = 0$$

$$r_3 = r_1 + r_2$$

3. A triangular matrix determinant is the product of the leading diagonal elements.

Example 7.25

$$|A| = \begin{vmatrix} 2 & 0 & 0 \\ 1 & 2 & 0 \\ 3 & 5 & 6 \end{vmatrix} = 2 \times 2 \times 6 = 24$$

4. If a matrix switches two parallel lines, its determinant changes sign.

Example 7.26

$$|A| = \begin{vmatrix} 2 & 1 & 2 \\ 1 & 2 & 0 \\ 3 & 5 & 6 \end{vmatrix} = - \begin{vmatrix} 1 & 2 & 0 \\ 2 & 1 & 2 \\ 3 & 5 & 6 \end{vmatrix}$$

5. If the elements of a line are added to the elements of another parallel line previously multiplied by a real number, the value of the determinant is unchanged.

Example 7.27

$$\begin{vmatrix} 2 & 1 & 2 \\ 1 & 2 & 0 \\ 3 & 5 & 6 \end{vmatrix} = 16 \quad c_3 = 2c_1 + c_2 + c_3 \quad \begin{vmatrix} 2 & 1 & 7 \\ 1 & 2 & 4 \\ 3 & 5 & 17 \end{vmatrix} = 16$$

6. If a determinant is multiplied by a real number, any line can be multiplied by the above mentioned number, but only one.

Example 7.28

$$2 \times \begin{vmatrix} 2 & 1 & 2 \\ 1 & 2 & 0 \\ 3 & 5 & 6 \end{vmatrix} = \begin{vmatrix} 2 \times 2 & 1 & 2 \\ 2 \times 1 & 2 & 0 \\ 2 \times 3 & 5 & 6 \end{vmatrix} = \begin{vmatrix} 4 & 1 & 2 \\ 2 & 2 & 0 \\ 6 & 5 & 6 \end{vmatrix} = 32$$

$$2 \times \begin{vmatrix} 2 & 1 & 2 \\ 1 & 2 & 0 \\ 3 & 5 & 6 \end{vmatrix} = 2 \times 16 = 32$$

7. If all the elements of a line are formed by two addends, the above mentioned determinant decomposes in the sum of two determinants.

Example 7.29

$$\begin{vmatrix} 2 & 1 & 2 \\ a+b & a+c & a+d \\ 3 & 5 & 6 \end{vmatrix} = \begin{vmatrix} 2 & 1 & 2 \\ a & a & a \\ 3 & 5 & 6 \end{vmatrix} + \begin{vmatrix} 2 & 1 & 2 \\ b & c & d \\ 3 & 5 & 6 \end{vmatrix}$$

8. The determinant of a product equals the product of the determinants.

$$|A \times B| = |A| \times |B|$$

Example 7.30

$$\text{Let } A = \begin{pmatrix} 1 & 2 & 1 \\ 2 & 4 & 8 \\ 3 & 2 & 3 \end{pmatrix}, B = \begin{pmatrix} 3 & -1 & 1 \\ 0 & 4 & 1 \\ 3 & 2 & 2 \end{pmatrix}$$

$$A \times B = \begin{pmatrix} 6 & 9 & 5 \\ 30 & 30 & 22 \\ 18 & 11 & 11 \end{pmatrix} \quad |A \times B| = \begin{vmatrix} 6 & 9 & 5 \\ 30 & 30 & 22 \\ 18 & 11 & 11 \end{vmatrix} = 72$$

$$|A| = \begin{vmatrix} 1 & 2 & 1 \\ 2 & 4 & 8 \\ 3 & 2 & 3 \end{vmatrix} = 24, \quad |B| = \begin{vmatrix} 3 & -1 & 1 \\ 0 & 4 & 1 \\ 3 & 2 & 2 \end{vmatrix} = 3$$

$$|A| \times |B| = 24 \times 3 = 72$$

Application Activity 7.8

Consider the following matrices $A = \begin{pmatrix} 12 & 0 & 1 \\ 34 & 0 & 2 \\ -3 & 0 & 3 \end{pmatrix}$,

$$B = \begin{pmatrix} 1 & 4 & 5 \\ 2 & 6 & 8 \\ 3 & 2 & 5 \end{pmatrix}, C = \begin{pmatrix} 6 & 7 & 6 \\ 2 & 4 & 8 \\ 1 & 3 & 9 \end{pmatrix}, D = \begin{pmatrix} -3 & 5 & 1 \\ 2 & 10 & 1 \\ 1 & 8 & 1 \end{pmatrix}$$

Find

- $|A|$, $|B|$, $|C|$ and $|D|$
- $|BC|$
- $|CD|$

7.3.2. Matrix inverse

Consider the matrix $A = \begin{pmatrix} 1 & 1 & 1 \\ 2 & 1 & -1 \\ 3 & 2 & 1 \end{pmatrix}$

- Calculate the determinant of A , $|A|$.
- Replace every element in matrix A by its cofactor to find a new matrix called cofactor matrix.

Activity 7.9



3. Find the transpose of the cofactor matrix.
4. Multiply the inverse value of determinant obtained in 1 by the matrix obtained in 3.
5. Multiply matrix A by matrix obtained in 4. Discuss your result.

Calculating matrix inverse of matrix A , is to find matrix A^{-1} such that,

$$A \cdot A^{-1} = A^{-1} \cdot A = I \text{ provided } \det A \neq 0$$

Where I is identity matrix.

From Activity 7.9, the matrix inverse of matrix A is equal to the inverse value of its determinant multiplied by the adjugate matrix. If $|A| \neq 0$ then the matrix is said to be regular or invertible. Then

$$A^{-1} = \frac{1}{|A|} \cdot \text{adj}(A)$$

Where $\text{adj}(A)$ is the **adjoint** (also called **adjugate**) matrix which is the transpose of the cofactor matrix. The cofactor matrix is found by replacing every element in matrix A by its cofactor. If $|A| = 0$, then the matrix is said to be singular or non-invertible. Then A^{-1} does not exist

Example 7.31

Find the inverse of the following matrix

$$A = \begin{pmatrix} 2 & 0 & 1 \\ 3 & 0 & 0 \\ 5 & 1 & 1 \end{pmatrix}$$

Solution

We find its inverse as follows:

a) $|A| = 3$

b) Cofactor of each element:

$$c(2) = \begin{vmatrix} 0 & 0 \\ 1 & 1 \end{vmatrix} = 0 \quad c(0) = -\begin{vmatrix} 3 & 0 \\ 5 & 1 \end{vmatrix} = -3 \quad c(1) = \begin{vmatrix} 3 & 0 \\ 5 & 1 \end{vmatrix} = 3$$

$$c(3) = -\begin{vmatrix} 0 & 1 \\ 1 & 1 \end{vmatrix} = 1 \quad c(0) = \begin{vmatrix} 2 & 1 \\ 5 & 1 \end{vmatrix} = -3 \quad c(0) = -\begin{vmatrix} 2 & 0 \\ 5 & 1 \end{vmatrix} = -2$$

$$c(5) = \begin{vmatrix} 0 & 0 \\ 0 & 1 \end{vmatrix} = 0 \quad c(1) = -\begin{vmatrix} 2 & 1 \\ 3 & 0 \end{vmatrix} = 3 \quad c(1) = \begin{vmatrix} 2 & 0 \\ 3 & 0 \end{vmatrix} = 0$$

The cofactor matrix is

$$\begin{pmatrix} 0 & -3 & 3 \\ 1 & -3 & -2 \\ 0 & 3 & 0 \end{pmatrix}, \text{ and then } \text{adj}(A) = \begin{pmatrix} 0 & 1 & 0 \\ -3 & -3 & 3 \\ 3 & -2 & 0 \end{pmatrix}$$

The matrix inverse of A is $A^{-1} = \frac{1}{|A|} \text{adj}(A) = \frac{1}{3} \begin{pmatrix} 0 & 1 & 0 \\ -3 & -3 & 3 \\ 3 & -2 & 0 \end{pmatrix}$

Therefore, $A^{-1} = \begin{pmatrix} 0 & \frac{1}{3} & 0 \\ -1 & -1 & 1 \\ 1 & \frac{-2}{3} & 0 \end{pmatrix}$

Application Activity 7.9

Find the inverse of the following matrices:

1. $A = \begin{pmatrix} 1 & 4 & 5 \\ 2 & 6 & 8 \\ 3 & 2 & 5 \end{pmatrix}$

2. $B = \begin{pmatrix} 11 & -8 & 1 \\ 0 & -6 & 2 \\ 3 & 2 & 7 \end{pmatrix}$

3. $C = \begin{pmatrix} 6 & 7 & 6 \\ 2 & 4 & 8 \\ 1 & 3 & 9 \end{pmatrix}$

4. $D = \begin{pmatrix} -3 & 5 & 1 \\ 2 & 10 & 1 \\ 1 & 8 & 1 \end{pmatrix}$

Properties of the inverse matrix

Activity 7.10



Consider the matrices $A = \begin{pmatrix} 1 & 0 & 1 \\ 1 & -1 & 1 \\ 0 & 0 & 2 \end{pmatrix}$ and $B = \begin{pmatrix} 2 & 1 & 1 \\ 1 & 1 & 1 \\ -1 & 1 & 0 \end{pmatrix}$ find

1. $(AB)^{-1}$ and $B^{-1}A^{-1}$ $(A^{-1})^{-1}$

3. $(4A)^{-1}$ and $\frac{1}{4}A^{-1}$ 4. $(A^t)^{-1}$ and $(A^{-1})^t$

What can you conclude for each result?

From Activity 7.10, for two invertible matrices A and B .

1. $(A \cdot B)^{-1} = B^{-1} \cdot A^{-1}$
2. $(A^{-1})^{-1} = A$
3. $(\alpha \cdot A)^{-1} = \alpha^{-1} \cdot A^{-1}$
4. $(A^t)^{-1} = (A^{-1})^t$

Example 7.32

Consider matrix $A = \begin{pmatrix} 1 & 1 & -2 \\ 0 & 1 & -1 \\ 3 & 0 & 0 \end{pmatrix}$ and $B = \begin{pmatrix} 0 & 1 & 0 \\ 2 & -2 & 0 \\ 1 & 1 & 1 \end{pmatrix}$, find

- a) A^{-1} and B^{-1} b) $(AB)^{-1}$ c) $(3B)^{-1}$ d) $(B^t)^{-1}$

Solution

$$\text{a) } |A| = 3, \quad \text{Adj}(A) = \begin{pmatrix} 0 & 0 & 1 \\ -3 & 6 & 1 \\ -3 & 3 & 1 \end{pmatrix}, \quad A^{-1} = \begin{pmatrix} 0 & 0 & \frac{1}{3} \\ -1 & 2 & \frac{1}{3} \\ -1 & 1 & \frac{1}{3} \end{pmatrix}$$

$$|B| = -2, \quad \text{Adj}(B) = \begin{pmatrix} -2 & -1 & 0 \\ -2 & 0 & 0 \\ 4 & 1 & -2 \end{pmatrix}, \quad B^{-1} = \begin{pmatrix} 1 & \frac{1}{2} & 0 \\ 1 & 0 & 0 \\ -2 & -\frac{1}{2} & 1 \end{pmatrix}$$

$$\text{b) } (AB)^{-1} = B^{-1}A^{-1} = \begin{pmatrix} 1 & \frac{1}{2} & 0 \\ 1 & 0 & 0 \\ -2 & -\frac{1}{2} & 1 \end{pmatrix} \begin{pmatrix} 0 & 0 & \frac{1}{3} \\ -1 & 2 & \frac{1}{3} \\ -1 & 1 & \frac{1}{3} \end{pmatrix} = \begin{pmatrix} -\frac{1}{2} & 1 & \frac{1}{2} \\ 0 & 0 & \frac{1}{3} \\ -\frac{1}{2} & 0 & -\frac{1}{2} \end{pmatrix}$$

$$\text{c) } (3B)^{-1} = \frac{1}{3}B^{-1} = \frac{1}{3} \begin{pmatrix} 1 & \frac{1}{2} & 0 \\ 1 & 0 & 0 \\ -2 & -\frac{1}{2} & 1 \end{pmatrix} = \begin{pmatrix} \frac{1}{3} & \frac{1}{6} & 0 \\ \frac{1}{3} & 0 & 0 \\ -\frac{2}{3} & -\frac{1}{6} & \frac{1}{3} \end{pmatrix}$$

$$d) (B')^{-1} = (B^{-1})' = \begin{pmatrix} 1 & \frac{1}{2} & 0 \\ 1 & 0 & 0 \\ -2 & -\frac{1}{2} & 1 \end{pmatrix}' = \begin{pmatrix} 1 & 1 & 2 \\ \frac{1}{2} & 0 & -\frac{1}{2} \\ 0 & 0 & 1 \end{pmatrix}$$

Application Activity 7.10

Consider the following matrices $A = \begin{pmatrix} 3 & 7 & 2 \\ 1 & 0 & 2 \\ 0 & 1 & 1 \end{pmatrix}$ and $B = \begin{pmatrix} 2 & -2 & 1 \\ 3 & 1 & 6 \\ -1 & 1 & 1 \end{pmatrix}$. Find;

- A^{-1} and B^{-1}
- $(A^{-1})^{-1}$
- $(10A)^{-1}$
- $(A')^{-1}$

7.4. Application

System of 3 linear equations

Activity 7.11



Consider the following system of 3 linear equations in 3 unknowns.

$$\begin{cases} a_{11}x + a_{12}y + a_{13}z = c_1 \\ a_{21}x + a_{22}y + a_{23}z = c_2 \\ a_{31}x + a_{32}y + a_{33}z = c_3 \end{cases}$$

- Rewrite this system in matrix form.
- If we premultiply (multiply to the left) both sides of the

equality obtained in 1) by $\begin{pmatrix} a_{11} & a_{12} & a_{13} \\ a_{21} & a_{22} & a_{23} \\ a_{31} & a_{32} & a_{33} \end{pmatrix}^{-1}$, what will be the new equality?

From Activity 7.11, the solution of the following system of 3 linear equations in 3 unknowns.

$$\begin{cases} a_{11}x + a_{12}y + a_{13}z = c_1 \\ a_{21}x + a_{22}y + a_{23}z = c_2 \\ a_{31}x + a_{32}y + a_{33}z = c_3 \end{cases}$$

is $\begin{pmatrix} x \\ y \\ z \end{pmatrix} = A^{-1}B$, provided that A^{-1} exists.

where

$$A = \begin{pmatrix} a_{11} & a_{12} & a_{13} \\ a_{21} & a_{22} & a_{23} \\ a_{31} & a_{32} & a_{33} \end{pmatrix} \text{ and } B = \begin{pmatrix} c_1 \\ c_2 \\ c_3 \end{pmatrix}$$



Notice

- ⊙ If at least one of c_i is different from zero, the system is said to be **non-homogeneous** and if all c_i are zero, the system is said to be **homogeneous**.
- ⊙ The set of values of x, y, z that satisfy all the equations of system (1) is called **solution of the system**.
- ⊙ For the homogeneous system, the solution $x = y = z = 0$ is called **trivial solution**. Other solutions are **non-trivial solutions**.
- ⊙ Non-homogeneous system cannot have a trivial solution as at least one of x, y, z is not zero.

Alternative method: Cramer's rule

Consider the system

$$\begin{cases} a_{11}x + a_{12}y + a_{13}z = c_1 \\ a_{21}x + a_{22}y + a_{23}z = c_2 \\ a_{31}x + a_{32}y + a_{33}z = c_3 \end{cases}$$

We use Cramer's rule as follows:

$$\Delta = \begin{vmatrix} a_{11} & a_{12} & a_{13} \\ a_{21} & a_{22} & a_{23} \\ a_{31} & a_{32} & a_{33} \end{vmatrix} \quad \Delta_x = \begin{vmatrix} c_1 & a_{12} & a_{13} \\ c_2 & a_{22} & a_{23} \\ c_3 & a_{32} & a_{33} \end{vmatrix}$$

$$\Delta_y = \begin{vmatrix} a_{11} & c_1 & a_{13} \\ a_{21} & c_2 & a_{23} \\ a_{31} & c_3 & a_{33} \end{vmatrix} \quad \Delta_z = \begin{vmatrix} a_{11} & a_{12} & c_1 \\ a_{21} & a_{22} & c_2 \\ a_{31} & a_{32} & c_3 \end{vmatrix}$$

$$x = \frac{\Delta_x}{\Delta}, \quad y = \frac{\Delta_y}{\Delta} \quad \text{and} \quad z = \frac{\Delta_z}{\Delta} \quad \text{provided } \Delta \neq 0$$

If $\Delta = 0$, then the system is not a Cramer's system; it may have no solution or infinitely many solutions.



Notice

- ⊙ The solution $\frac{b}{0}, b \neq 0$ means impossible.
- ⊙ The solution $\frac{0}{0}$ means indeterminate.

Example 7.33

Solve

$$\begin{cases} x + y + z = 6 \\ 2x + y - z = 1 \\ 3x + 2y + z = 10 \end{cases}$$

Solution

$$\begin{pmatrix} 1 & 1 & 1 \\ 2 & 1 & -1 \\ 3 & 2 & 1 \end{pmatrix} \begin{pmatrix} x \\ y \\ z \end{pmatrix} = \begin{pmatrix} 6 \\ 1 \\ 10 \end{pmatrix}$$

$$A = \begin{pmatrix} 1 & 1 & 1 \\ 2 & 1 & -1 \\ 3 & 2 & 1 \end{pmatrix}, \quad X = \begin{pmatrix} x \\ y \\ z \end{pmatrix}, \quad B = \begin{pmatrix} 6 \\ 1 \\ 10 \end{pmatrix}$$

We find the inverse of A.

A is invertible if its determinant is not zero.

$$\det(A) = \begin{vmatrix} 1 & 1 & 1 \\ 2 & 1 & -1 \\ 3 & 2 & 1 \end{vmatrix} = 1 + 4 - 3 - 3 + 2 - 2 = -1 \neq 0, \text{ then } A \text{ has inverse.}$$

We have seen that the adjugate matrix and determinant of a matrix are used to find its inverse.

Let us use another useful method:

We have $A = \begin{pmatrix} 1 & 1 & 1 \\ 2 & 1 & -1 \\ 3 & 2 & 1 \end{pmatrix}$, to find its inverse, suppose that its

inverse is given by

$$A^{-1} = \begin{pmatrix} a & d & g \\ b & e & h \\ c & f & i \end{pmatrix}$$

We know that $AA^{-1} = I$, then

$$\begin{pmatrix} 1 & 1 & 1 \\ 2 & 1 & -1 \\ 3 & 2 & 1 \end{pmatrix} \begin{pmatrix} a & d & g \\ b & e & h \\ c & f & i \end{pmatrix} = \begin{pmatrix} 1 & 0 & 0 \\ 0 & 1 & 0 \\ 0 & 0 & 1 \end{pmatrix} \Rightarrow \begin{cases} \begin{cases} a+b+c=1 \\ 2a+b-c=0 \\ 3a+2b+c=0 \end{cases} & (1) \\ \begin{cases} d+e+f=0 \\ 2d+e-f=1 \\ 3d+2e+f=0 \end{cases} & (2) \\ \begin{cases} g+h+i=0 \\ 2g+h-i=0 \\ 3g+2h+i=1 \end{cases} & (3) \end{cases}$$

We solve these three systems to find value of a, b, c, d, e, f, g, h , and i .

$$\begin{cases} a+b+c=1 \\ 2a+b-c=0 \\ 3a+2b+c=0 \end{cases} \quad (1) \Rightarrow \begin{cases} a=-3 \\ b=5 \\ c=-1 \end{cases}$$

$$\begin{cases} d+e+f=0 \\ 2d+e-f=1 \\ 3d+2e+f=0 \end{cases} \quad (2) \Rightarrow \begin{cases} d=-1 \\ e=2 \\ f=-1 \end{cases}$$

$$\begin{cases} g+h+i=0 \\ 2g+h-i=0 \\ 3g+2h+i=1 \end{cases} \quad (3) \Rightarrow \begin{cases} g=2 \\ h=-3 \\ i=1 \end{cases}$$

Then,

$$A^{-1} = \begin{pmatrix} -3 & -1 & 2 \\ 5 & 2 & -3 \\ -1 & -1 & 1 \end{pmatrix} \quad X = \begin{pmatrix} x \\ y \\ z \end{pmatrix} = \begin{pmatrix} -3 & -1 & 2 \\ 5 & 2 & -3 \\ -1 & -1 & 1 \end{pmatrix} \begin{pmatrix} 6 \\ 1 \\ 10 \end{pmatrix} = \begin{pmatrix} 1 \\ 2 \\ 3 \end{pmatrix}$$

Therefore, $S = \{(1, 2, 3)\}$

Alternative method

$$\Delta = \begin{vmatrix} 1 & 1 & 1 \\ 2 & 1 & -1 \\ 3 & 2 & 1 \end{vmatrix} = -1 \qquad \Delta_x = \begin{vmatrix} 6 & 1 & 1 \\ 1 & 1 & -1 \\ 10 & 2 & 1 \end{vmatrix} = -1$$

$$\Delta_y = \begin{vmatrix} 1 & 6 & 1 \\ 2 & 1 & -1 \\ 3 & 10 & 1 \end{vmatrix} = -2 \qquad \Delta_z = \begin{vmatrix} 1 & 1 & 6 \\ 2 & 1 & 1 \\ 3 & 2 & 10 \end{vmatrix} = -3$$

$$x = \frac{\Delta_x}{\Delta} = \frac{-1}{-1} = 1, \quad y = \frac{\Delta_y}{\Delta} = \frac{-2}{-1} = 2, \quad z = \frac{\Delta_z}{\Delta} = \frac{-3}{-1} = 3$$

Therefore, $S = \{(1, 2, 3)\}$

Application Activity 7.11

Use matrix inverse method to solve the following systems

$$1. \begin{cases} 3x + y + z = 0 \\ 2x - y + 2z = 0 \\ 7x + y - 3z = 0 \end{cases} \qquad 2. \begin{cases} 4x + y - z = 1 \\ x - 3y + z = 2 \\ 5x - 2y = 4 \end{cases} \qquad 3. \begin{cases} x + y - z = 3 \\ 3x - y + z = 1 \\ -2x + y + z = 0 \end{cases}$$

Unit Summary

1. Square matrix of order three has the form

$$\begin{pmatrix} a_{11} & a_{12} & a_{13} \\ a_{21} & a_{22} & a_{23} \\ a_{31} & a_{32} & a_{33} \end{pmatrix}$$

2. In an upper triangular matrix, the elements located below the leading diagonal are zeros.

3. In a lower triangular matrix, the elements above the leading diagonal are zeros.

4. In a diagonal matrix, all the elements above and below the leading diagonal are zeros.
5. A scalar matrix is a diagonal matrix in which the leading diagonal elements are equal.
6. An identity matrix (denoted by **I**) is a diagonal matrix in which the leading diagonal elements are equal to 1.

7. If
$$\begin{pmatrix} a_{11} & a_{12} & a_{13} \\ a_{21} & a_{22} & a_{23} \\ a_{31} & a_{32} & a_{33} \end{pmatrix} = \begin{pmatrix} b_{11} & b_{12} & b_{13} \\ b_{21} & b_{22} & a_{23} \\ b_{31} & b_{32} & b_{33} \end{pmatrix},$$
 then

$$a_{11} = b_{11}, a_{12} = b_{12}, a_{13} = b_{13}$$

$$a_{21} = b_{21}, a_{22} = b_{22}, a_{23} = b_{23}$$

$$a_{31} = b_{31}, a_{32} = b_{32}, a_{33} = b_{33}$$

8. If
$$A = \begin{pmatrix} a_{11} & a_{12} & a_{13} \\ a_{21} & a_{22} & a_{23} \\ a_{31} & a_{32} & a_{33} \end{pmatrix}$$
 and
$$B = \begin{pmatrix} b_{11} & b_{12} & b_{13} \\ b_{21} & b_{22} & b_{23} \\ b_{31} & b_{32} & b_{33} \end{pmatrix},$$
 then

$$A + B = \begin{pmatrix} a_{11} & a_{12} & a_{13} \\ a_{21} & a_{22} & a_{23} \\ a_{31} & a_{32} & a_{33} \end{pmatrix} + \begin{pmatrix} b_{11} & b_{12} & b_{13} \\ b_{21} & b_{22} & b_{23} \\ b_{31} & b_{32} & b_{33} \end{pmatrix} = \begin{pmatrix} a_{11} + b_{11} & a_{12} + b_{12} & a_{13} + b_{13} \\ a_{21} + b_{21} & a_{22} + b_{22} & a_{23} + b_{23} \\ a_{31} + b_{31} & a_{32} + b_{32} & a_{33} + b_{33} \end{pmatrix}$$

$$A - B = \begin{pmatrix} a_{11} & a_{12} & a_{13} \\ a_{21} & a_{22} & a_{23} \\ a_{31} & a_{32} & a_{33} \end{pmatrix} - \begin{pmatrix} b_{11} & b_{12} & b_{13} \\ b_{21} & b_{22} & b_{23} \\ b_{31} & b_{32} & b_{33} \end{pmatrix} = \begin{pmatrix} a_{11} - b_{11} & a_{12} - b_{12} & a_{13} - b_{13} \\ a_{21} - b_{21} & a_{22} - b_{22} & a_{23} - b_{23} \\ a_{31} - b_{31} & a_{32} - b_{32} & a_{33} - b_{33} \end{pmatrix}$$

9. If
$$A = \begin{pmatrix} a_{11} & a_{12} & a_{13} \\ a_{21} & a_{22} & a_{23} \\ a_{31} & a_{32} & a_{33} \end{pmatrix},$$
 then
$$kA = \begin{pmatrix} ka_{11} & ka_{12} & ka_{13} \\ ka_{21} & ka_{22} & ka_{23} \\ ka_{31} & ka_{32} & ka_{33} \end{pmatrix}$$

10. If
$$A = \begin{pmatrix} a_{11} & a_{12} & a_{13} \\ a_{21} & a_{22} & a_{23} \\ a_{31} & a_{32} & a_{33} \end{pmatrix},$$
 then
$$A^t = \begin{pmatrix} a_{11} & a_{21} & a_{31} \\ a_{12} & a_{22} & a_{32} \\ a_{13} & a_{23} & a_{33} \end{pmatrix}$$

11. If
$$A = \begin{pmatrix} a_{11} & a_{12} & a_{13} \\ a_{21} & a_{22} & a_{23} \\ a_{31} & a_{32} & a_{33} \end{pmatrix}$$
 and
$$B = \begin{pmatrix} b_{11} & b_{12} & b_{13} \\ b_{21} & b_{22} & b_{23} \\ b_{31} & b_{32} & b_{33} \end{pmatrix},$$
 then

$$\begin{aligned}
 A \cdot B &= \begin{pmatrix} a_{11} & a_{12} & a_{13} \\ a_{21} & a_{22} & a_{23} \\ a_{31} & a_{32} & a_{33} \end{pmatrix} \cdot \begin{pmatrix} b_{11} & b_{12} & b_{13} \\ b_{21} & b_{22} & b_{23} \\ b_{31} & b_{32} & b_{33} \end{pmatrix} \\
 &= \begin{pmatrix} a_{11}b_{11} + a_{12}b_{21} + a_{13}b_{31} & a_{11}b_{12} + a_{12}b_{22} + a_{13}b_{32} & a_{11}b_{13} + a_{12}b_{23} + a_{13}b_{33} \\ a_{21}b_{11} + a_{22}b_{21} + a_{23}b_{31} & a_{21}b_{12} + a_{22}b_{22} + a_{23}b_{32} & a_{21}b_{13} + a_{22}b_{23} + a_{23}b_{33} \\ a_{31}b_{11} + a_{32}b_{21} + a_{33}b_{31} & a_{31}b_{12} + a_{32}b_{22} + a_{33}b_{32} & a_{31}b_{13} + a_{32}b_{23} + a_{33}b_{33} \end{pmatrix}
 \end{aligned}$$

12. The sum of the entries on the leading diagonal of a square matrix, A , is known as the **trace** of that matrix, denoted $tr(A)$

13. Every linear transformation $f: \mathbb{R}^3 \rightarrow \mathbb{R}^3$ can be identified with a matrix of order three, $[f]_e = (a_{ij})$, whose j^{th} column is $f(e_j)$ where $\{\bar{e}_j\}$, $j=1,2,3$ is the standard basis of \mathbb{R}^3 . The matrix $[f]_e$ is called matrix representation of f relative to the standard basis $\{\bar{e}_j\}$.

14. Let $\{\bar{e}_i\}$, $\{\bar{f}_i\}$ and $\{\bar{g}_i\}$ be bases of E , U and V respectively. Let $f: E \rightarrow U$ and $g: U \rightarrow V$ be linear mappings. Then $[g \circ f]_{e_i}^{g_i} = [g]_{f_i}^{g_i} [f]_{e_i}^{f_i}$. That is, relative to the appropriate bases, the matrix representation of the composition of two linear mappings is equal to the product of the matrix representations of the individual mappings.

15. Let $\{\bar{e}_i\}$, $\{\bar{f}_i\}$ and $\{\bar{g}_i\}$ be bases of E , U and V respectively. Let $f: E \rightarrow U$ and $g: U \rightarrow V$ be linear mappings. Then $[g \circ f]_{e_i}^{g_i} = [g]_{f_i}^{g_i} [f]_{e_i}^{f_i}$. That is, relative to the appropriate bases, the matrix representation of the composition of two linear mappings is equal to the product of the matrix representations of the individual mappings. or any $f, g \in L(E)$ and any scalar $\alpha \in K$,

a) $[g + f]_e = [g]_e + [f]_e$ and

b) $[\alpha g]_e = \alpha [g]_e$.

16. Consider an arbitrary 3x3 matrix, $A = \begin{pmatrix} a_{11} & a_{12} & a_{13} \\ a_{21} & a_{22} & a_{23} \\ a_{31} & a_{32} & a_{33} \end{pmatrix}$.
The determinant of A is defined as follows:

$$|A| = \begin{vmatrix} a_{11} & a_{12} & a_{13} \\ a_{21} & a_{22} & a_{23} \\ a_{31} & a_{32} & a_{33} \end{vmatrix} = a_{11}a_{22}a_{33} + a_{12}a_{23}a_{31} + a_{13}a_{21}a_{32} - a_{13}a_{22}a_{31} - a_{12}a_{21}a_{33} - a_{11}a_{23}a_{32}$$

17. Steps to Calculate the Inverse Matrix

- Calculate the determinant of A , $|A|$. If the determinant is zero the matrix has no inverse.
- Find the cofactor matrix which is found by replacing every element in matrix A by its cofactor.
- Find the **adjugate** (or **classical adjoint**) matrix, denoted $adj(A)$, which is the transpose of the cofactor matrix.
- The matrix inverse is equal to the inverse value of its determinant multiplied by the adjugate matrix.

18. Consider the following system:

$$\begin{cases} a_{11}x + a_{12}y + a_{13}z = c_1 \\ a_{21}x + a_{22}y + a_{23}z = c_2 \\ a_{31}x + a_{32}y + a_{33}z = c_3 \end{cases} \quad (1)$$

The system (1) can be written in the form

$$\begin{pmatrix} a_{11} & a_{12} & a_{13} \\ a_{21} & a_{22} & a_{23} \\ a_{31} & a_{32} & a_{33} \end{pmatrix} \begin{pmatrix} x \\ y \\ z \end{pmatrix} = \begin{pmatrix} c_1 \\ c_2 \\ c_3 \end{pmatrix} \text{ and the solution of system (1) is given}$$

$$\text{by } \begin{pmatrix} x \\ y \\ z \end{pmatrix} = \begin{pmatrix} a_{11} & a_{12} & a_{13} \\ a_{21} & a_{22} & a_{23} \\ a_{31} & a_{32} & a_{33} \end{pmatrix}^{-1} \begin{pmatrix} c_1 \\ c_2 \\ c_3 \end{pmatrix}, \text{ provided that } \begin{pmatrix} a_{11} & a_{12} & a_{13} \\ a_{21} & a_{22} & a_{23} \\ a_{31} & a_{32} & a_{33} \end{pmatrix}^{-1}$$

exists.

Or we can use Cramer's rule as follows:

$$\Delta = \begin{vmatrix} a_{11} & a_{12} & a_{13} \\ a_{21} & a_{22} & a_{23} \\ a_{31} & a_{32} & a_{33} \end{vmatrix} \quad \Delta_x = \begin{vmatrix} c_1 & a_{12} & a_{13} \\ c_2 & a_{22} & a_{23} \\ c_3 & a_{32} & a_{33} \end{vmatrix}$$

$$\Delta_y = \begin{vmatrix} a_{11} & c_1 & a_{13} \\ a_{21} & c_2 & a_{23} \\ a_{31} & c_3 & a_{33} \end{vmatrix} \quad \Delta_z = \begin{vmatrix} a_{11} & a_{12} & c_1 \\ a_{21} & a_{22} & c_2 \\ a_{31} & a_{32} & c_3 \end{vmatrix}$$

$$x = \frac{\Delta_x}{\Delta}, \quad y = \frac{\Delta_y}{\Delta} \quad \text{and} \quad z = \frac{\Delta_z}{\Delta}$$

End of Unit Assessment

1. If $A = \begin{pmatrix} 3 & -1 & 3 \\ 1 & 0 & -6 \\ 0 & -4 & 2 \end{pmatrix}$, $B = \begin{pmatrix} 10 & 2 & 3 \\ 1 & -4 & 6 \\ 0 & 6 & 4 \end{pmatrix}$ and $C = \begin{pmatrix} 11 & 12 & 0 \\ 1 & 0 & 8 \\ 2 & 0 & 7 \end{pmatrix}$

Evaluate

- a) $A - B$ b) $A + B - 2C$ c) $2A - B + C$
 d) $A \times B$ e) $A \times C$ f) $B \times C$

2. Find the matrix of the following map relative to the canonical basis

$$f: \mathbb{R}^3 \rightarrow \mathbb{R}^3$$

$$f(x, y, z) = (2x + y, y - z, 2x + 4y)$$

3. Let f be a linear operator on \mathbb{R}^3 defined by

$$f(x, y, z) = (2y + z, x - 4y, 3x)$$

a) Find the matrix of f in the basis

$$\{e_1 = (1, 1, 1), e_2 = (1, 1, 0), e_3 = (1, 0, 0)\}$$

b) Verify that $[f]_e[v]_e = [f(v)]_e$ for any vector $v \in \mathbb{R}^3$

4. Find the inverse of:

a) $A = \begin{pmatrix} 1 & 0 & 0 \\ 1 & 1 & 0 \\ 1 & 1 & 1 \end{pmatrix}$ b) $B = \begin{pmatrix} 2 & -2 & 0 \\ 1 & 3 & 4 \\ 3 & 1 & 4 \end{pmatrix}$ c) $C = \begin{pmatrix} 5 & 0 & 1 \\ 2 & 3 & 7 \\ 1 & 8 & 4 \end{pmatrix}$

5. Using matrix inverse method, solve $A \cdot X + 2 \cdot B = 3 \cdot C$ if

$$A = \begin{pmatrix} 1 & 0 & 0 \\ 1 & 1 & 0 \\ 1 & 1 & 1 \end{pmatrix} \quad B = \begin{pmatrix} 0 & 1 & 1 \\ 1 & 0 & 0 \\ 0 & 0 & 1 \end{pmatrix} \quad C = \begin{pmatrix} 1 & 0 & 0 \\ 0 & 1 & 0 \\ 1 & 0 & 1 \end{pmatrix}$$

6. Use matrix inverse method to solve

a) $\begin{cases} x + 3y + 3z = 0 \\ 3x + 4y - z = 0 \\ -3x - 9y + z = 0 \end{cases}$ b) $\begin{cases} x + y + z = 3 \\ 2x - y = 1 \\ 4x + y - z = 4 \end{cases}$ c) $\begin{cases} -x + y - z = -4 \\ 3x + 10y + z = 10 \\ x - y - z = 2 \end{cases}$

7. If $f(x) = x^3 - 20x + 8$, find $f(A)$ if $A = \begin{pmatrix} 1 & 1 & 3 \\ 1 & 3 & -3 \\ -2 & -4 & -4 \end{pmatrix}$

8. Find the condition of k such that $A = \begin{pmatrix} 1 & 3 & 4 \\ 3 & k & 6 \\ -1 & 5 & 1 \end{pmatrix}$ be no singular matrix. Obtain A^{-1} for $k = 1$.

9. If $A = \begin{pmatrix} 1 & 2 & -1 \\ 0 & 1 & 2 \\ -1 & 0 & -2 \end{pmatrix}$

a) Show that $A^3 - 4A + 7I = O$ where I, O are the unit and the null matrix of order 3 respectively. Use this result to find A^{-1} .

b) Find the matrix X such that $AX = \begin{pmatrix} 2 \\ 1 \\ -7 \end{pmatrix}$

10. Given $A = \begin{pmatrix} 2 & -2 & -1 \\ 1 & 1 & -2 \\ 3 & 1 & -3 \end{pmatrix}$, find A^3 and hence solve the equations

$$\text{a) } \begin{cases} 2x - 2y - z = -18 \\ x + y - 2z = -2 \\ 3x + y - 3z = -10 \end{cases}$$

$$\text{b) } \begin{cases} x + 7y - 5z = 9 \\ x + y - z = 3 \\ x + 4y - 2z = 6 \end{cases}$$

11. Find, in terms of t , the determinant of the matrix

$$A = \begin{pmatrix} 2-t & 1 & 3 \\ 1 & 1-t & 1 \\ -1 & -1 & -2-t \end{pmatrix}$$

12. If A is a square matrix of order 3 such that $\det A = x$, find the value of:

a) $\det(A^2)$

b) $\det(A^n), n \in \mathbb{Z}$

c) $\det(2A)$

d) $\det(mA), m \in \mathbb{R}$

13. Find the value of k for each of the following system of equations

$$\begin{cases} 3x - 2y + 2z = 3 \\ x + ky - 3z = 0 \\ 4x + y + 2z = 5 \end{cases} \text{ are consistent}$$

14. For what value of λ and μ the following system of equations

$$\begin{cases} 2x + 3y + 5z = 9 \\ 7x + 3y - z = 1 \\ 4x + 3y + \lambda z = \mu \end{cases}$$

will have

- a) no solution
- b) unique solution
- c) more than one solution

Unit 8

Points, Straight Lines, Planes and Sphere in 3D

Introductory activity

Observe handcraft objects and a bed design on the diagrams below:

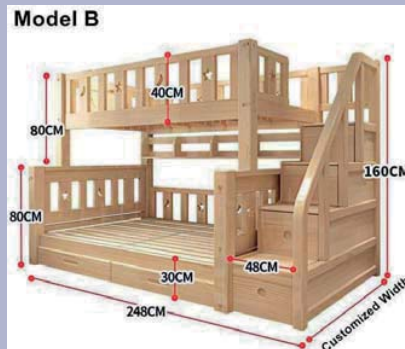

- Write down parts that can represent points, lines, angles, planes and shapes on these objects and explain your answer in each case.
- What are essential data required to draw a line in a 2D, or in a 3D space?

Objectives

By the end of this unit, a student will be able to:

- Plot points in three dimensions.
- Find equation of straight lines in three dimensions.
- Find equation of planes in three dimensions.
- Position of lines and planes in space.
- Find equation of sphere.

8.1. Points in 3 dimensions

8.1.1. Location of a point in space



Activity 8.1

Consider the point $A(2,3,5)$ in space, on a piece of paper

1. Copy the following figure

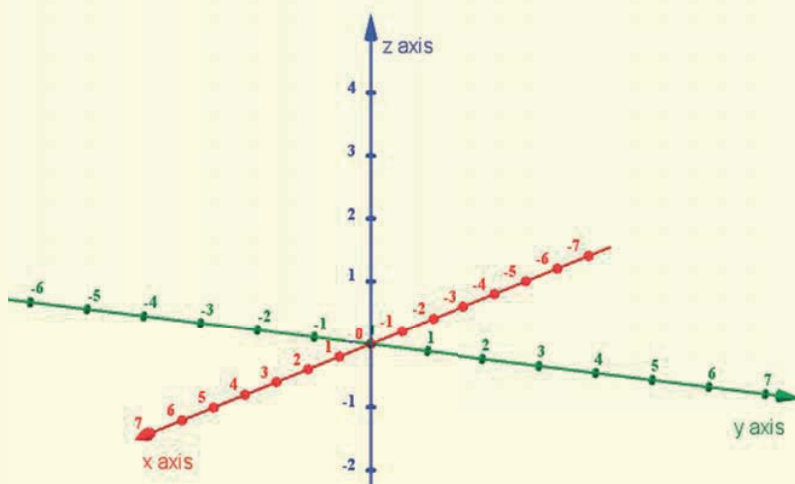

2. From x -coordinate 2, draw a line parallel to y -axis.
3. From y -coordinate 3, draw another line parallel to x -axis.
4. Now you have a point of intersection of two lines, let us call it P . From this point, draw another line parallel to z -axis and another joining this point and origin of coordinates which is line OP .
5. From z -coordinate, draw another line parallel to the line OP .
6. Draw another line parallel to z -axis and passing through point P .

Suppose that we need to represent the point $A(2,3,5)$ in space. From Activity 8.1, we have

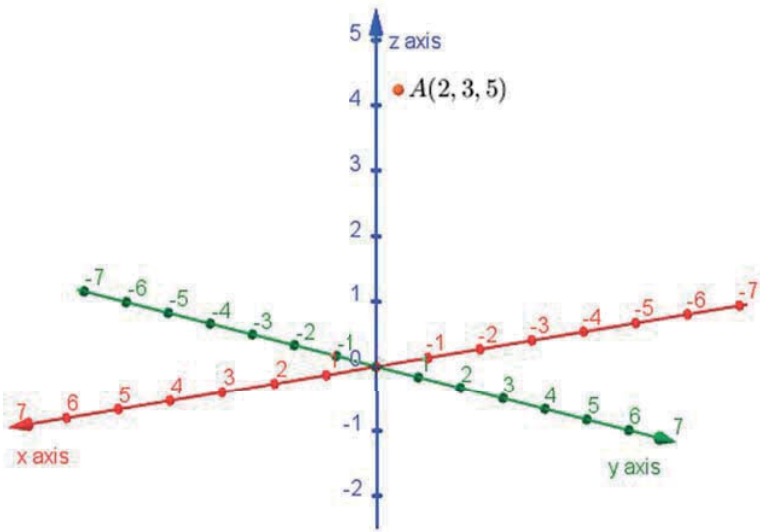

Let us see it using a box

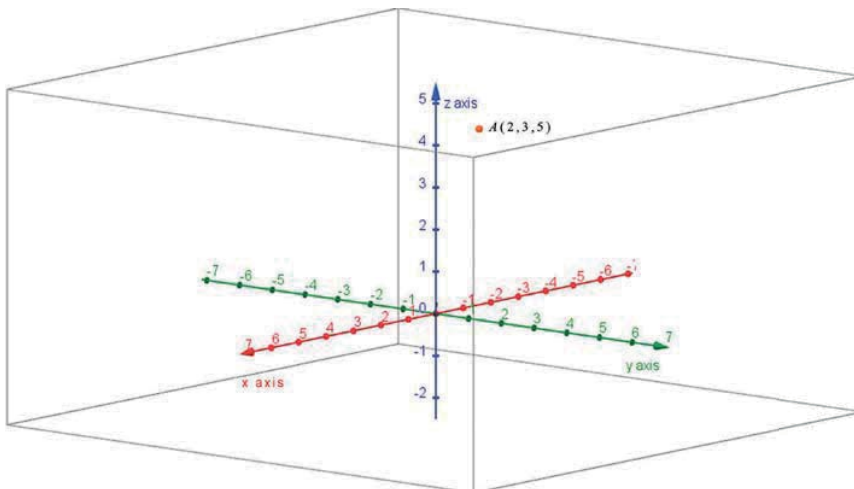

Example 8.1

Represent in space

- Points $O(0,0,0)$, $A(1,-4,5)$, $B(5,2,1)$
- Vector \vec{OA} , $\vec{u} = (3,4,-2)$
- Segment $[CD]$ for $C(-4,5,3)$ and $D(6,4,-2)$

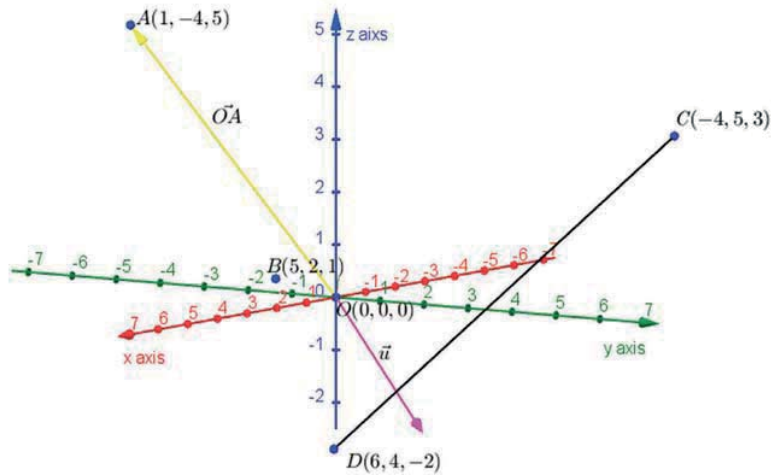
Solution**Application Activity 8.1**

Represent the following points in space

$$A(1, 1, 1), B(-1, 2, 3), C(3, 4, 1)$$

$$D(-2, 1, 2), E(3, 2, 1), F(-2, 0, 1)$$

8.1.2. Coordinates of a midpoint of a segment and centroid of a geometric figure

**Activity 8.2**

1. Consider the points $A(4, 3, 1), B(-1, 2, 5)$. Find $\frac{1}{2}(A + B)$.
2. Consider the points $A(2, 11, 1), B(4, -6, 1), C(-12, 0, -1)$. Find $\frac{1}{3}(A + B + C)$.

Coordinates of a midpoint of a segment

The point halfway between the end points of a line segment is called the **midpoint**. A midpoint divides a line segment into two equal parts.

Let the points (x_1, y_1, z_1) and (x_2, y_2, z_2) be the end points of a line segment, then the midpoint of that segment is given by the formula:

$$\left(\frac{x_1 + x_2}{2}, \frac{y_1 + y_2}{2}, \frac{z_1 + z_2}{2} \right)$$

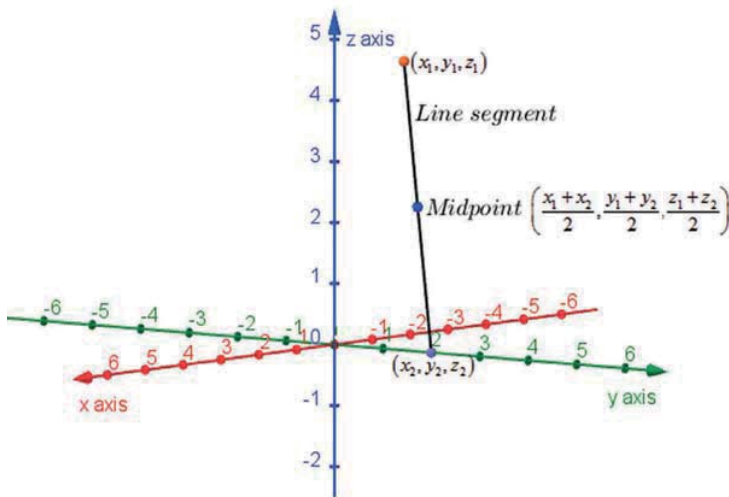

Example 8.2

Find the coordinates of the midpoint of the line joining $(1, 2, 3)$ and $(3, 2, 1)$

Solution

The coordinates of the midpoint of the line joining $(1, 2, 3)$ and $(3, 2, 1)$ is given by $\left(\frac{1+3}{2}, \frac{2+2}{2}, \frac{3+1}{2} \right)$ which is $(2, 2, 2)$.

Centroid of a geometric figure

The **centroid of geometric figure** is the arithmetic mean (average) position of all points in the shape. In geometry, the synonym of centroid is **barycentre or geometric centre**. In physics, barycentre means the **physical centre** of mass or the **centre of gravity**.

Let $(x_1, y_1, z_1), (x_2, y_2, z_2), \dots, (x_n, y_n, z_n)$ be n points of space, their centroid is given by the formula:

$$\left(\frac{x_1 + x_2 + \dots + x_n}{n}, \frac{y_1 + y_2 + \dots + y_n}{n}, \frac{z_1 + z_2 + \dots + z_n}{n} \right)$$

Example 8.3

Determine the centroid of the triangle built from the points $(1, 4, 2)$, $(-1, -3, 4)$ and $(2, 5, 6)$

Solution

The centroid of the triangle built from the points $(1, 4, 2)$, $(-1, -3, 4)$ and $(2, 5, 6)$ is given by $\left(\frac{1-1+2}{3}, \frac{4-3+5}{3}, \frac{2+4+6}{3} \right)$ which is $\left(\frac{2}{3}, 2, 4 \right)$.

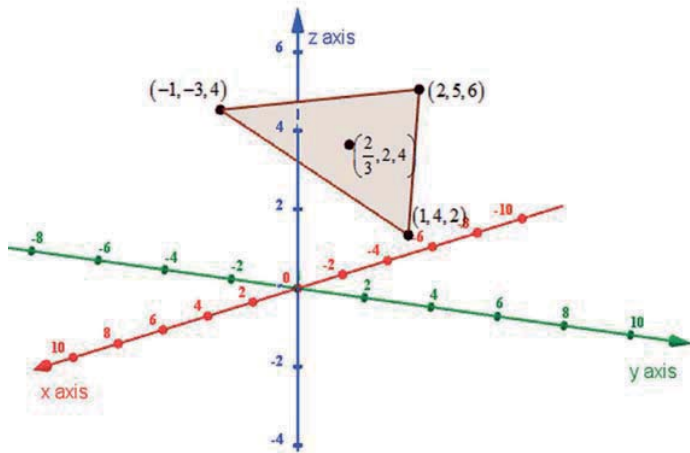

Application Activity 8.2

- Find the coordinates of the midpoint of the line joining segment
 - $(1, 3, 6)$ and $(-1, 4, 5)$
 - $(11, 2, 4)$ and $(1, 3, -5)$
 - $(-9, 8, 2)$ and $(2, 3, 8)$
 - $(6, 2, 0)$ and $(0, 0, 1)$
- Find the centroid of the figure built from the points
 - $(6, 2, 0), (2, 4, 6)$ and $(0, 0, 1)$
 - $(2, 3, 8), (1, -4, 6)$ and $(3, 0, 4)$
 - $(-5, 4, 10), (1, 3, 2), (0, 3, 7)$ and $(2, 5, 9)$
 - $(-2, -3, -1), (2, 4, 1), (0, 3, 0)$ and $(4, -4, 9)$

8.1.3. The ratio formula

Activity 8.3



1. Let P be a point on the line joining point A and point B . P divides this line internally (means that it lies between A and B) in the ratio $m:n$

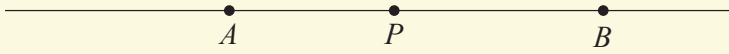

We have $\overrightarrow{AP} = \frac{m}{n} \overrightarrow{PB}$. Develop this relation to obtain the expression equal to P .

Let point P divide the line externally (meaning that it does not lie between A and B) in the ratio $m:n$, we have

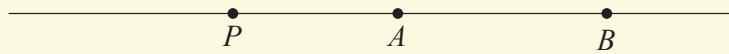

Or

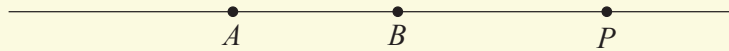

We have, $\overrightarrow{PA} = \frac{m}{n} \overrightarrow{PB}$ or $\overrightarrow{AP} = \frac{m}{n} \overrightarrow{BP}$. Develop these two relations to obtain the expression equal to P .

From Activity 8.3, if P is a point on the line AB such that P divides AB internally in the ratio $m:n$, then $P = \frac{mB + nA}{m+n}$ and if P divides AB externally in the ratio $m:n$, then $P = \frac{mB - nA}{m-n}$.

Example 8.4

Find the position of the point P which divides $[AB]$

- internally in the ratio 1:3
- externally in the ratio 2:5

Solution

- a) If P divides $[AB]$ internally in the ratio 1:3, we have

$$\begin{aligned} P &= \frac{B+3A}{4} \\ &= \frac{3}{4}A + \frac{1}{4}B \end{aligned}$$

b) If P divides $[AB]$ externally in the ration 2:5, we have

$$\begin{aligned} P &= \frac{2B - 5A}{-3} \\ &= \frac{5}{3}A - \frac{2}{3}B \end{aligned}$$

Application Activity 8.3

- For A (2, 1, 5) and B (4, 3, 7) determine the point that divides AB in the ratio of 2:3.
- Find the coordinates of the point which divides the line joining (1,2,3) to (3,-4,5) in the ratio 5:6.
- Find the coordinates of the point which divides the line joining (5,4,2) to (-1,-2,4) in the ratio
 - 2:3
 - 2:3
- Find the coordinates of the point which divides the line joining (-2,3,5) to (1,-4,-6) in the ratio
 - 2:3 internally
 - 2:3 externally
- $P(-1,-1,-1), Q(1,3,2), R(5,11,8)$ are three points in a straight line. Find the ratio in which Q divides PR .
- The point P lies on the line joining the points $A(7,2,1)$ and $B(10,5,7)$. If the y -coordinates of P is 4, find its other coordinates.

8.2. Straight lines in 3 dimensions

8.2.1. Equations of lines

In the plane, a line is determined by a point and a number giving the slope of the line. In 3-dimensional space, a line is determined by a point and a direction given by a parallel vector, called the **direction vector** of the line. We will denote lines by capital letters such as L, M, \dots

a) Line defined by a position vector and a direction vector

Activity 8.4



A line which is parallel to the vector $\vec{v} = (a, b, c)$ and passing through the point P with position vector $\vec{OP} = (x_0, y_0, z_0)$ has equation $\vec{OQ} = \vec{OP} + r\vec{v}$ with $O(0, 0, 0)$ and $Q(x, y, z)$, any other point on the line and r is a parameter.

1. In the equation $\vec{OQ} = \vec{OP} + r\vec{v}$, replace each vector by its coordinates and equate the respective components to obtain new equations.
2. Solve for parameter r in each equation obtained in 1 to obtain other equations.

From Activity 8.4, a line which is parallel to the vector $\vec{v} = (a, b, c)$ and passing through the point P with position vector $\vec{OP} = (x_0, y_0, z_0)$, has

- **Vector equation** $\vec{OQ} = \vec{OP} + r\vec{v}$ or $(x, y, z) = (x_0, y_0, z_0) + r(a, b, c)$ or $x\vec{i} + y\vec{j} + z\vec{k} = x_0\vec{i} + y_0\vec{j} + z_0\vec{k} + r(a\vec{i} + b\vec{j} + c\vec{k})$, where r is a parameter.

- **The parametric equations**

$$\begin{cases} x = x_0 + ra \\ y = y_0 + rb \\ z = z_0 + rc \end{cases}$$

- **The Cartesian equations (or symmetric equations)**

$$\frac{x - x_0}{a} = \frac{y - y_0}{b} = \frac{z - z_0}{c}$$

The line is entirely determined by two of these three equations, that is, from these symmetric equations we have

$$\begin{cases} \frac{x - x_0}{a} = \frac{y - y_0}{b} \\ \frac{x - x_0}{a} = \frac{z - z_0}{c} \\ \frac{y - y_0}{b} = \frac{z - z_0}{c} \end{cases} \Leftrightarrow \begin{cases} b(x - x_0) = a(y - y_0) \\ c(x - x_0) = a(z - z_0) \\ c(y - y_0) = b(z - z_0) \end{cases}$$

We can take

$$\begin{cases} b(x-x_0) = a(y-y_0) \\ c(x-x_0) = a(z-z_0) \end{cases} \text{ or } \begin{cases} b(x-x_0) = a(y-y_0) \\ c(y-y_0) = b(z-z_0) \end{cases} \text{ or}$$

$$\begin{cases} c(x-x_0) = a(z-z_0) \\ c(y-y_0) = b(z-z_0) \end{cases}$$

More simply, we can find the Cartesian equation of the line passing through the point $P(x_0, y_0, z_0)$ and parallel to the direction vector $\vec{v} = (a, b, c)$ in the following manner:

$$\begin{vmatrix} x-x_0 & a \\ y-y_0 & b \end{vmatrix} = \begin{vmatrix} x-x_0 & a \\ z-z_0 & c \end{vmatrix} = \begin{vmatrix} y-y_0 & b \\ z-z_0 & c \end{vmatrix} = 0$$

Or

$$\begin{vmatrix} x & x_0 & a \\ y & y_0 & b \\ 1 & 1 & 0 \end{vmatrix} = \begin{vmatrix} x & x_0 & a \\ z & z_0 & c \\ 1 & 1 & 0 \end{vmatrix} = \begin{vmatrix} y & y_0 & b \\ z & z_0 & c \\ 1 & 1 & 0 \end{vmatrix} = 0$$

Example 8.5

Find the vector, parametric and symmetric equations of the line L passing through the point $A(3, -2, 4)$ with direction vector $\vec{u} = (2, 3, 5)$.

Solution

Let $P(x, y, z)$ be any point on the line.

Vector equation:

$L \equiv \overline{AP} = t\vec{u}$, with $A(3, -2, 4)$, $\vec{u} = (2, 3, 5)$ and t is a parameter.

Or

$$L \equiv \begin{pmatrix} x \\ y \\ z \end{pmatrix} = \begin{pmatrix} 3 \\ -2 \\ 4 \end{pmatrix} + t \begin{pmatrix} 2 \\ 3 \\ 5 \end{pmatrix}$$

Or

$$L \equiv x\vec{i} + y\vec{j} + z\vec{k} = 3\vec{i} - 2\vec{j} + 4\vec{k} + t(2\vec{i} + 3\vec{j} + 5\vec{k})$$

Parametric equations:

$$L \equiv \begin{cases} x = 3 + 2t \\ y = -2 + 3t \\ z = 4 + 5t \end{cases}$$

Symmetric equations:

Eliminating the parameter t gives,

$$L \equiv \frac{x-3}{2} = \frac{y+2}{3} = \frac{z-4}{5}$$

Or we can take any two equations

$$\begin{cases} \frac{x-3}{2} = \frac{y+2}{3} \\ \frac{x-3}{2} = \frac{z-4}{5} \end{cases} \Leftrightarrow \begin{cases} 3x-9 = 2y+4 \\ 5x-15 = 2z-8 \end{cases} \Leftrightarrow \begin{cases} 3x-2y-13 = 0 \\ 5x-2z-7 = 0 \end{cases}$$

Or we can use the determinant

$$\begin{vmatrix} x-3 & 2 \\ y+2 & 3 \end{vmatrix} = \begin{vmatrix} x-3 & 2 \\ z-4 & 5 \end{vmatrix} = \begin{vmatrix} y+2 & 3 \\ z-4 & 5 \end{vmatrix} = 0$$

Taking two of them, we have

$$\begin{cases} \begin{vmatrix} x-3 & 2 \\ y+2 & 3 \end{vmatrix} = 0 \\ \begin{vmatrix} x-3 & 2 \\ z-4 & 5 \end{vmatrix} = 0 \end{cases} \Leftrightarrow \begin{cases} 3x-9-2y-4 = 0 \\ 5x-15-2z+8 = 0 \end{cases} \quad L \equiv \begin{cases} 3x-2y-13 = 0 \\ 5x-2z-7 = 0 \end{cases}$$

Or we can use the following determinants

$$\begin{vmatrix} x & 3 & 2 \\ y & -2 & 3 \\ 1 & 1 & 0 \end{vmatrix} = \begin{vmatrix} x & 3 & 2 \\ z & 4 & 5 \\ 1 & 1 & 0 \end{vmatrix} = \begin{vmatrix} y & -2 & 3 \\ z & 4 & 5 \\ 1 & 1 & 0 \end{vmatrix} = 0$$

Taking two of them, we have

$$\begin{cases} \begin{vmatrix} x & 3 & 2 \\ y & -2 & 3 \\ 1 & 1 & 0 \end{vmatrix} = 0 \\ \begin{vmatrix} x & 3 & 2 \\ z & 4 & 5 \\ 1 & 1 & 0 \end{vmatrix} = 0 \end{cases} \Leftrightarrow \begin{cases} 0+2y+9+4-3x = 0 \\ 0+2z+15-8-5x = 0 \end{cases} \Leftrightarrow \begin{cases} -3x+2y+13 = 0 \\ -5x+2z+7 = 0 \end{cases}$$

And finally,

$$L \equiv \begin{cases} 3x - 2y - 13 = 0 \\ 5x - 2z - 7 = 0 \end{cases}$$



Notice

It is acceptable to give the symmetric equations of the line in the form $\frac{x-a}{p} = \frac{y-b}{q} = \frac{z-c}{r}$, where (a, b, c) is the point on the line and (p, q, r) is the direction vector of the line, even when one or more of p, q and r is zero.

Example 8.6

Write down the symmetric equations of the line L passing through the point $A(2, 1, 4)$ with direction vector $\vec{u} = (1, 0, -2)$.

Solution

Symmetric equations

$$\frac{x-2}{1} = \frac{y-1}{0} = \frac{z-4}{-2}$$

Or simply

$$\frac{x-2}{1} = \frac{z-4}{-2}, y=1$$

Application Activity 8.4

Find the vector, parametric and symmetric equations of the line L passing through

1. the point $A(1, 1, 1)$ with direction vector $\vec{u} = (2, 1, 3)$.
2. the point $A(-2, 3, 1)$ with direction vector $\vec{u} = (2, 1, 3)$.
3. the point $A(9, 3, 0)$ with direction vector $\vec{u} = (1, 1, 6)$.
4. the point $A(4, 5, 2)$ with direction vector $\vec{u} = (-3, 2, 1)$.

b) Line defined by two position vectors

**Activity 8.5**

Consider a line passing through points $P(x_0, y_0, z_0)$ and $Q(x_1, y_1, z_1)$, as we can construct a vector from two points; this line can be considered as the line passing through point $P(x_0, y_0, z_0)$ or point $Q(x_1, y_1, z_1)$ with direction vector \overrightarrow{PQ} .

1. Write down the vector equations of this line. You suppose that this line is passing through point $P(x_0, y_0, z_0)$ with direction vector \overrightarrow{PQ} . Use r as a parameter and $V(x, y, z)$ as any point on the line.
2. Equate the respective components to obtain parametric equations.
3. Remove parameter r (find the value of parameter in each equation of parametric equations) to obtain symmetric equations.

From Activity 8.5, a line passes through points $P(x_0, y_0, z_0)$ and $Q(x_1, y_1, z_1)$; and $V(x, y, z)$ any point on the line has

Vector equation $\overrightarrow{PV} = r\overrightarrow{PQ}$, where r is a parameter.

Parametric equations:

$$\begin{cases} x = x_0 + r(x_1 - x_0) \\ y = y_0 + r(y_1 - y_0) \\ z = z_0 + r(z_1 - z_0) \end{cases}$$

The symmetric equations:

$$\frac{x - x_0}{x_1 - x_0} = \frac{y - y_0}{y_1 - y_0} = \frac{z - z_0}{z_1 - z_0}$$

Or we can take two of them

$$\begin{cases} \frac{x - x_0}{x_1 - x_0} = \frac{y - y_0}{y_1 - y_0} \\ \frac{x - x_0}{x_1 - x_0} = \frac{z - z_0}{z_1 - z_0} \\ \frac{y - y_0}{y_1 - y_0} = \frac{z - z_0}{z_1 - z_0} \end{cases} \Leftrightarrow \begin{cases} (x - x_0)(y_1 - y_0) = (y - y_0)(x_1 - x_0) \\ (x - x_0)(z_1 - z_0) = (z - z_0)(x_1 - x_0) \\ (y - y_0)(z_1 - z_0) = (z - z_0)(y_1 - y_0) \end{cases}$$

Taking two of them, we have

$$\begin{cases} (x-x_0)(y_1-y_0) = (y-y_0)(x_1-x_0) \\ (x-x_0)(z_1-z_0) = (z-z_0)(x_1-x_0) \end{cases}$$

Or

$$\begin{cases} (x-x_0)(y_1-y_0) = (y-y_0)(x_1-x_0) \\ (y-y_0)(z_1-z_0) = (z-z_0)(y_1-y_0) \end{cases}$$

Or

$$\begin{cases} (x-x_0)(z_1-z_0) = (z-z_0)(x_1-x_0) \\ (y-y_0)(z_1-z_0) = (z-z_0)(y_1-y_0) \end{cases}$$

These equations can be found using determinants:

$$\begin{vmatrix} x-x_0 & x_1-x_0 \\ y-y_0 & y_1-y_0 \end{vmatrix} = \begin{vmatrix} x-x_0 & x_1-x_0 \\ z-z_0 & z_1-z_0 \end{vmatrix} = \begin{vmatrix} y-y_0 & y_1-y_0 \\ z-z_0 & z_1-z_0 \end{vmatrix} = 0$$

Or

$$\begin{vmatrix} x & x_0 & x_1 \\ y & y_0 & y_1 \\ 1 & 1 & 1 \end{vmatrix} = \begin{vmatrix} x & x_0 & x_1 \\ z & z_0 & z_1 \\ 1 & 1 & 1 \end{vmatrix} = \begin{vmatrix} y & y_0 & y_1 \\ z & z_0 & z_1 \\ 1 & 1 & 1 \end{vmatrix} = 0$$

Example 8.7

Find vector, parametric and symmetric equations of the line M passing through the points $A(3, -2, 5)$ and $B(1, 4, -2)$.

Solution

First, we find the direction vector, which is $\overline{AB} = (-2, 6, -7)$

Vector equation:

$$M \equiv \overline{AV} = r\overline{AB}, \text{ with } V(x, y, z) \text{ and } r \text{ is a parameter.}$$

Parametric equations:

$$M \equiv \begin{cases} x = 3 - 2r \\ y = -2 + 6r \\ z = 5 - 7r \end{cases}$$

Symmetric equations (eliminating parameter r):

$$M \equiv \frac{-x+3}{2} = \frac{y+2}{6} = \frac{-z+5}{7}$$

Or we can take two of them

$$\begin{cases} \frac{-x+3}{2} = \frac{y+2}{6} \\ \frac{-x+3}{2} = \frac{-z+5}{7} \\ \frac{y+2}{6} = \frac{-z+5}{7} \end{cases} \Leftrightarrow \begin{cases} -6x+18=2y+4 \\ -7x+21=-2z+10 \\ 7y+14=-6z+30 \end{cases}$$

$$\Leftrightarrow \begin{cases} -6x-2y+14=0 \\ -7x+2z+11=0 \\ 7y+6z-16=0 \end{cases} \Leftrightarrow \begin{cases} 3x+y-7=0 \\ 7x-2z-11=0 \\ 7y+6z-16=0 \end{cases}$$

Taking two of them, we have

$$\begin{cases} 3x+y-7=0 \\ 7x-2z-11=0 \end{cases}$$

Or we can use determinants

$$\begin{vmatrix} x-3 & -2 \\ y+2 & 6 \end{vmatrix} = \begin{vmatrix} x-3 & -2 \\ z-5 & -7 \end{vmatrix} = \begin{vmatrix} y+2 & 6 \\ z-5 & -7 \end{vmatrix} = 0$$

Taking two of them, we have

$$\begin{vmatrix} x-3 & -2 \\ y+2 & 6 \end{vmatrix} = 0 \text{ and } \begin{vmatrix} x-3 & -2 \\ z-5 & -7 \end{vmatrix} = 0$$

$$\Leftrightarrow \begin{cases} 6x-18+2y+4=0 \\ -7x+21+2z-10=0 \end{cases} \quad M \equiv \begin{cases} 3x+y-7=0 \\ 7x-2z-11=0 \end{cases}$$

Or

$$\begin{vmatrix} x & 3 & 1 \\ y & -2 & 4 \\ 1 & 1 & 1 \end{vmatrix} = \begin{vmatrix} x & 3 & 1 \\ z & 5 & -2 \\ 1 & 1 & 1 \end{vmatrix} = \begin{vmatrix} y & -2 & 4 \\ z & 5 & -2 \\ 1 & 1 & 1 \end{vmatrix} = 0$$

Taking two of them, we have

$$\begin{vmatrix} x & 3 & 1 \\ y & -2 & 4 \\ 1 & 1 & 1 \end{vmatrix} = 0 \text{ and } \begin{vmatrix} x & 3 & 1 \\ z & 5 & -2 \\ 1 & 1 & 1 \end{vmatrix} = 0$$

$$\Leftrightarrow \begin{cases} -2x+y+12+2-4x-3y=0 \\ 5x+z-6-5+2x-3z=0 \end{cases} \Leftrightarrow \begin{cases} -6x-2y+14=0 \\ 7x-2z-11=0 \end{cases}$$

And finally,

$$M \equiv \begin{cases} 3x + y - 7 = 0 \\ 7x - 2z - 11 = 0 \end{cases}$$

Application Activity 8.5

Find vector, parametric and symmetric equations of the line M passing through the points

1. $A(2,1,4)$ and $B(3,1,1)$.
2. $A(1,1,3)$ and $B(2,5,4)$.
3. $A(2,1,4)$ and $B(6,3,2)$.
4. $A(1,1,1)$ and $B(4,5,6)$.

8.2.2. Condition of co-linearity of 3 points

Activity 8.6



From the method of finding equation of a line passing through two given points, determine which of the following sets of points lie on the same line

$$A = \{(1,2,3), (1,-4,3), (-1,0,5)\}$$

$$B = \{(2,1,-3), (1,-7,6), (-4,4,0)\}$$

$$C = \{(1,9,3), (1,8,5), (1,10,1)\}$$

Establish a condition for which three given points may satisfy to lie on the same line.

The three points $A(a_1, a_2, a_3)$, $B(b_1, b_2, b_3)$ and $C(c_1, c_2, c_3)$ are collinear (meaning that they lie on the same line) if the following conditions are satisfied

$$\begin{vmatrix} a_1 & b_1 & c_1 \\ a_2 & b_2 & c_2 \\ 1 & 1 & 1 \end{vmatrix} = \begin{vmatrix} a_1 & b_1 & c_1 \\ a_2 & b_2 & c_2 \\ 1 & 1 & 1 \end{vmatrix} = 0$$

Alternative method:

Three points A , B and C are collinear if the vectors formed from these points are linearly dependent. That is, $\overrightarrow{AB} = k\overrightarrow{AC}$, $k \in \mathbb{R}_0$

Example 8.8

Prove that points $A(2, -1, 3)$, $B(4, 3, 5)$ and $C(6, 7, 7)$ are collinear.

Solution

Remember that the three points

(a_1, a_2, a_3) ; (b_1, b_2, b_3) and (c_1, c_2, c_3) are collinear if

$$\begin{vmatrix} a_1 & b_1 & c_1 \\ a_2 & b_2 & c_2 \\ a_3 & b_3 & c_3 \end{vmatrix} = \begin{vmatrix} a_1 & b_1 & c_1 \\ a_2 & b_2 & c_2 \\ a_3 & b_3 & c_3 \end{vmatrix} = 0$$

$$\text{Or } \begin{vmatrix} 2 & 4 & 6 \\ -1 & 3 & 7 \\ 1 & 1 & 1 \end{vmatrix} = 6 - 6 + 28 - 18 - 14 + 4 = 0$$

$$\begin{vmatrix} 2 & 4 & 6 \\ 3 & 5 & 7 \\ 1 & 1 & 1 \end{vmatrix} = 10 + 18 + 28 - 30 - 14 - 12 = 0$$

Thus, the three points are collinear.

Alternative method

$$\overline{AB} = (2, 4, 2), \overline{AC} = (4, 8, 4)$$

We see that $\overline{AC} = 2\overline{AB}$

Thus, the three points are collinear.

Application Activity 8.6

1. Verify if the points $A(2, 3, 1)$, $B(5, 4, 3)$, $C(2, 1, 2)$ are collinear.
2. Show that the points $A(1, 1, 1)$, $B(3, 2, 4)$, $C(-1, 0, -2)$ are collinear and find the equations, in parametric form, of the line they lie on.
3. Find the value of a for which the points $(-1, 2, 3)$, $(2, 1, 5)$, $(5, 0, a)$ are collinear.

8.2.3. Relationships between lines

Activity 8.7



In each of the following pair of lines, after verifying if they are parallel, determine whether they are coincident or different. If not parallel, find intersection point if any.

1. $L_1 : \vec{r} = (2 - \lambda)\vec{i} + 2(1 + \lambda)\vec{j} + (1 + 3\lambda)\vec{k}$,

$$L_2 : 6(1 - x) = 3(y - 1) = 2(z - 1)$$

2. $L_1 : x = \frac{y+2}{2} = 5 - z$, $L_2 : \frac{x-1}{-1} = \frac{-3-y}{3} = z - 4$

3. $L_1 : \vec{r} = 5\vec{i} + 4\vec{j} + 5\vec{k} + \lambda(2\vec{i} + \vec{j} + \vec{k})$, $L_2 : x - 1 = 2(y - 2) = 2(z - 3)$

4. $L_1 : \begin{cases} x = 2 + 8s \\ y = 4 - 3s \\ z = 5 + s \end{cases}$ $L_2 : \begin{cases} x = 1 + 4t \\ y = 5 - 4t \\ z = -1 + 5t \end{cases}$

Parallel lines not only fail to intersect, but also maintain constant separation between points closest to each other on two lines. Therefore, parallel lines lie in a single plane.

The two lines are parallel if their direction vectors are scalar multiples. If two lines are parallel, there are two possible cases: the lines may be identical or strictly parallel. If you find a point on one line which does not lie on the other, the two lines are strictly parallel but if you find a point on one line which lie on the other, the lines are identical.

In 3-dimensional space, there is one more possibility. Two lines may be **skew**, which means that they do not intersect, but are not parallel.



Lines r and s are coincident

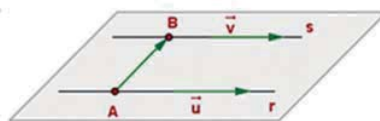

Lines r and s are parallel and distinct

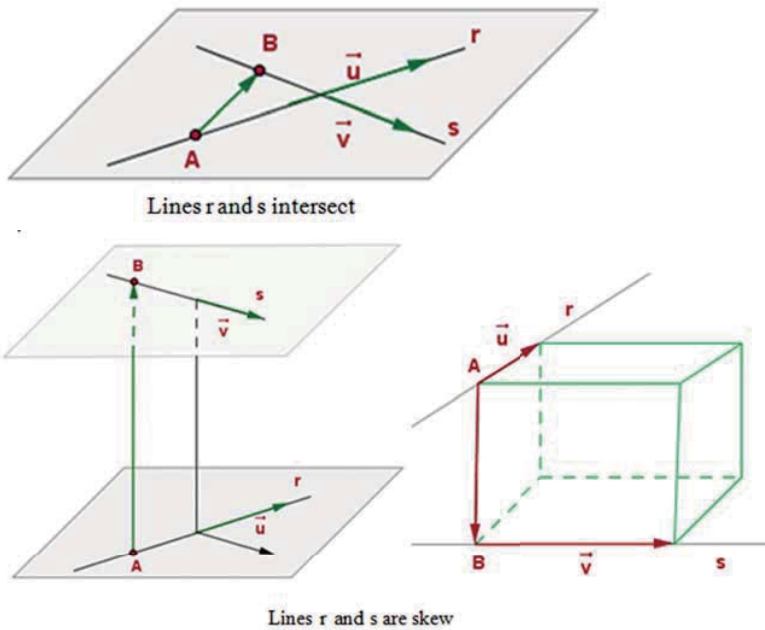

Example 8.9

Determine if the lines are parallel, intersect, skew or identical

$$L_1 \equiv \begin{cases} x = 3 + t \\ y = 2 - 2t \\ z = 4 + t \end{cases} \quad L_2 \equiv \begin{cases} x = 5 - 2t \\ y = -2 + 4t \\ z = 1 - 2t \end{cases}$$

Solution

First, we see that the direction vectors are $\vec{u} = (1, -2, 1)$ and $\vec{v} = (-2, 4, -2)$ (coefficients of parameter).

From two direction vectors, we see that they are scalar multiple since $\vec{v} = -2\vec{u}$, meaning that the two lines are parallel.

Now, we must determine if they are identical. So, we need to determine if they pass through the same points. We need to determine if the two sets of parametric equations produce the same points for different values of t .

Let $t = 0$ for L_1 , the point produced is $(3, 2, 4)$.

Set the x from L_2 equal to the x -coordinate produced by L_1 and solve for t .

$$3 = 5 - 2t \Leftrightarrow -2 = -2t \Rightarrow t = 1$$

Now $t=1$ for L_2 and the point $(3,2,-1)$ is produced. Since the z-coordinates are not equal, the lines are not identical.

So, they are parallel and distinct.

Example 8.10

Determine if the lines intersect. If so, find the point of intersection.

$$\text{Line 1: } \begin{cases} x = 3 + 2t \\ y = -2t \\ z = 4 - t \end{cases} \quad \text{Line 2: } \begin{cases} x = 4 - s \\ y = 3 + 5s \\ z = 2 - s \end{cases}$$

Solution

Direction vectors: $\vec{v}_1 = (2, -2, -1)$ $\vec{v}_2 = (-1, 5, -1)$

Since $\vec{v}_2 \neq k \cdot \vec{v}_1$, the lines are not parallel. Thus, they either intersect or they are skew lines.

Keep in mind that the lines may have a point of intersection or a common point, but not necessarily for the same value of parameters. So equate corresponding coordinates to get:

$$\begin{cases} 3 + 2t = 4 - s \\ -2t = 3 + 5s \\ 4 - t = 2 - s \end{cases}$$

System of 3 equations with 2 unknowns – Solve the first 2 and check with the 3rd equation.

Solving the system, we get $t = 1$ and $s = -1$.

Line 1: $t = 1$ produces the point $(5, -2, 3)$

Line 2: $s = -1$ produces the point $(5, -2, 3)$

The lines intersect at this point.

Example 8.11

Find parametric equations of line L_1 passing through the point $(-1, 0, 1)$ and parallel to the line

$$L_2 \equiv \begin{cases} x = 2 + r \\ y = 1 + 2r \\ z = 3 + 3r \end{cases}$$

Are the two lines identical or strictly parallel?

Solution

Since the two lines are parallel, their direction vectors are scalar multiples. We can take $(1, 2, 3)$ as the direction vector for L_1 . Thus,

$$L_1 \equiv \begin{cases} x = -1 + t \\ y = 2t \\ z = 1 + 3t \end{cases}$$

Now, let us check if there is a common point for two lines. We solve the following system:

$$\begin{cases} 2 + r = -1 + t \\ 1 + 2r = 2t \\ 3 + 3r = 1 + 3t \end{cases}$$

Taking the first two equations, we have

$$\begin{cases} 2 + r = -1 + t \\ 1 + 2r = 2t \end{cases} \Rightarrow \begin{cases} -4 - 2r = 2 - 2t \\ 1 + 2r = 2t \end{cases}$$

$$\underline{\hspace{10em}}$$

$$-3 = 2$$

The obtained statement is false means that there is no common point. Hence, the two lines are parallel and distinct.

Example 8.12

Determine whether the following lines are identical or parallel and distinct

$$L_1 \equiv \begin{cases} x = 2 + r \\ y = 1 + 2r \\ z = 3 + 3r \end{cases} \quad L_2 \equiv \begin{cases} x = 3 - t \\ y = 3 - 2t \\ z = 6 - 3t \end{cases}$$

Solution

Two direction vectors for two lines are scalar multiples, meaning that the two lines are parallel. To determine if they are distinct or identical, we need to check if there is a common point for two lines.

For this, let $r = 0$, for first line we have the point $(2, 1, 3)$. Using x -coordinate of this point in second line, we obtain $2 = 3 - t \Rightarrow t = 1$. For this value of t , second line produces the point $(2, 1, 3)$. Then

this is one of the common points.

Or

To check if there is a common point for two lines: we solve the following system:

$$\begin{cases} 2+r=3-t \\ 1+2r=3-2t \\ 3+3r=6-3t \end{cases}$$

Taking the first two equations, we have

$$\begin{cases} 2+r=3-t \\ 1+2r=3-2t \end{cases} \Rightarrow \begin{cases} -4-2r=-6+2t \\ 1+2r=3-2t \end{cases}$$

$$-3 = -3$$

The obtained statement is true, meaning that there are two points on two lines with same x and y components.

Now, we check for z component. Taking the first and the last equations, we have

$$\begin{cases} 2+r=3-t \\ 3+3r=6-3t \end{cases} \Rightarrow \begin{cases} -6-3r=-9+3t \\ 3+3r=6-3t \end{cases}$$

$$-3 = -3$$

Again, the obtained statement is true. Then there are two points on two lines with same x, y and z components. Thus, there is a common point.

Hence, the two lines are identical.

Example 8.13

Determine if the lines intersect. If so, find the point of intersection.

$$\text{Line 1: } \begin{cases} x=1+t \\ y=2+3t \\ z=4+3t \end{cases} \quad \text{Line 2: } \begin{cases} x=1-2s \\ y=2-4s \\ z=1-s \end{cases}$$

Solution

Direction vectors: $\vec{v}_1 = (1, 3, 3)$ $\vec{v}_2 = (-2, -4, -1)$

Since $\vec{v}_2 \neq k \cdot \vec{v}_1$, the lines are not parallel.

Thus, they either intersect or they are skew lines.

Equating corresponding coordinates gives

$$1+t=1-2s$$

$$2+3t=2-4s$$

$$4+3t=1-s$$

Solve the first 2 equations and check with the 3rd equation.

$$\begin{cases} 1+t=1-2s \\ 2+3t=2-4s \end{cases} \Rightarrow t=s=0$$

If we check for the third equation, we get $4=1$, which is false. Meaning that there are no values of t and s which verify the system.

Thus, the lines do not intersect.

Hence, the given lines are skew lines.

Example 8.14

Prove that the lines $x-1=2-y=\frac{z+5}{2}$ and $\vec{r}=2\mu\vec{i}-3\vec{j}+(\mu-2)\vec{k}$ are skew.

Solution

Direction vector of first line is $\vec{u}=(1,-1,2)$ and direction vector of second line is $\vec{v}=(2,0,1)$.

$\vec{u} \neq k\vec{v}$, then the two lines are not parallel.

Parametric equations of first line:

$$\begin{cases} x=1+t \\ y=2-t \\ z=2t-5 \end{cases}$$

Parametric equations of second line:

$$\begin{cases} x=2\mu \\ y=-3 \\ z=\mu-2 \end{cases}$$

These two lines meet when

$$\begin{cases} 1+t=2\mu \\ 2-t=-3 \\ 2t-5=\mu-2 \end{cases}$$

From the first two equations, $t=5$ and $\mu=3$ but these values do not verify the third equation since $2(5)-5=5$ and $3-2=1$.

Therefore, the lines are skew.

Application Activity 8.7

In each of the following, decide whether the given lines are skew or they intersect. If they intersect, find the coordinates of their common point.

1. $4x = 4y = z + 3$ and $\frac{x-7}{2} = y-5 = \frac{z-12}{6}$

2. $\vec{r} = -2\vec{i} - 3\vec{j} - 13\vec{k} + \lambda(2\vec{i} + 2\vec{j} + 3\vec{k})$ and
 $\vec{r} = -\vec{i} + 3\vec{j} - 5\vec{k} + \mu(3\vec{i} - 2\vec{j} - 2\vec{k})$

3. $\frac{x-1}{2} = y-1 = z-2$ and $x-4 = \frac{y+2}{3} = \frac{z+1}{-2}$

4. $\frac{x-1}{2} = \frac{2y+1}{2} = \frac{1-z}{2}$ and $\frac{x}{2} = \frac{1-y}{3} = z$

5. $L \equiv \frac{x-1}{2} = \frac{y}{1} = \frac{z-1}{1}$ and $M \equiv \frac{x}{1} = \frac{y}{-1} = \frac{z}{-1}$

6. $L \equiv \begin{cases} x+y+z-3=0 \\ 2x-y+z-2=0 \end{cases}$ and $M \equiv \frac{x-1}{2} = \frac{y-1}{1} = \frac{z-1}{3}$

8.2.4. Angle between two lines



Activity 8.8

Consider two lines $L_1 : \vec{r} = 5\vec{i} + 4\vec{j} + 5\vec{k} + \lambda(\vec{i} + \vec{j} - \vec{k})$
 $L_2 : x-1 = \frac{y+2}{5} = 3-z$.

1. Find the angle between their direction vectors.
2. Try and find the angle between these two lines.

Remember this: Depending on the position of observer, between two non perpendicular lines, there are two angles there are two angles between two lines (acute and obtuse)..

We define the angle between two lines to be the acute angle (angle which lies between 0 and 90 degrees) between their direction vectors, say \vec{u} and \vec{v} , placed tail to tail.

Note that this definition works equally well if the lines do not actually cut each other since we then just slide the two direction vectors together until their tails meet.

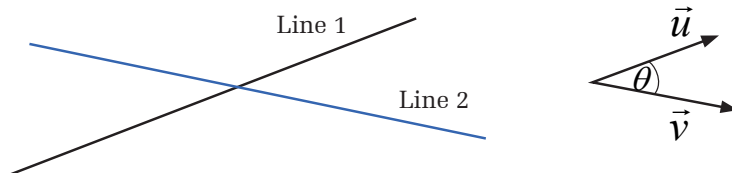

The angle between the lines is found by working out the dot product of \vec{u} and \vec{v} .

$$\text{We have } \vec{u} \cdot \vec{v} = \|\vec{u}\| \|\vec{v}\| \cos \theta$$

$$\text{From this, knowing } \vec{u} \text{ and } \vec{v}, \theta \text{ is given by } \theta = \arccos \left(\frac{\vec{u} \cdot \vec{v}}{\|\vec{u}\| \|\vec{v}\|} \right)$$

Example 8.15

Calculate the angle between the lines AB and AC for $A(1,2,3)$, $B(4,5,6)$ and $C(3,2,0)$.

Solution

Line AB has direction vector $\vec{u} = (3,3,3)$

Line AC has direction vector $\vec{v} = (2,0,-3)$

Let θ be the angle between two lines, then $\cos \theta = \frac{6+0-9}{\sqrt{27}\sqrt{13}} = \frac{-3}{\sqrt{351}}$

$$\theta = \arccos \left(\frac{-3}{\sqrt{351}} \right) = 99.2^\circ$$

The acute angle is $180^\circ - 99.2^\circ = 80.8^\circ$

Thus, between the lines AB and AC is 80.8 degrees.

Application Activity 8.8

Find the angle between the lines

$$1. \quad L_1 \equiv \begin{cases} x = 1+t \\ y = 4+t \\ z = 8 \end{cases} \quad L_2 \equiv \begin{cases} x = 1+2t \\ y = 1+t \\ z = -1-2t \end{cases}$$

$$2. \quad L_1 \equiv \begin{cases} x = 2+2t \\ y = 1+2t \\ z = -2+2t \end{cases} \quad L_2 \equiv \begin{cases} x = 2+2t \\ y = 4-2t \\ z = -1-t \end{cases}$$

to the nearest hundredth of a radian

$$3. L_1 \equiv \begin{cases} x = 6 + 2t \\ y = 8 + 2t \\ z = -7 - t \end{cases} \quad L_2 \equiv \begin{cases} x = 2 + t \\ y = 1 + 2t \\ z = -1 + t \end{cases}$$

to the nearest hundredth of a radian

$$4. L_1 \equiv \begin{cases} x = 1 + t \\ y = 10 + 2t \\ z = -2 - 2t \end{cases} \quad L_2 \equiv \begin{cases} x = -4 + 6t \\ y = 1 - 3t \\ z = -1 + 2t \end{cases}$$

to the nearest degree

$$5. L \equiv \frac{x-2}{2} = \frac{y+1}{1} = \frac{z}{1} \quad M \equiv \frac{x+1}{-1} = \frac{y}{2} = \frac{z}{1}$$

$$6. L \equiv \begin{cases} 2x + 3y - z + 1 = 0 \\ x - y + 2z + 2 = 0 \end{cases} \quad M \equiv \begin{cases} 3x - y + z - 3 = 0 \\ 2x + y - 3z + 1 = 0 \end{cases}$$

$$7. L \equiv \frac{x+1}{1} = \frac{y-1}{2} = \frac{z-2}{3} \quad M \equiv \begin{cases} x + y + z = 0 \\ 2x - y + 3z - 1 = 0 \end{cases}$$

8.2.5. Distance from a point to a line

The **distance** between two geometric objects always means the minimum distance between two points, one in each.

Activity 8.9



Consider the following figure. BQ is perpendicular to line l .

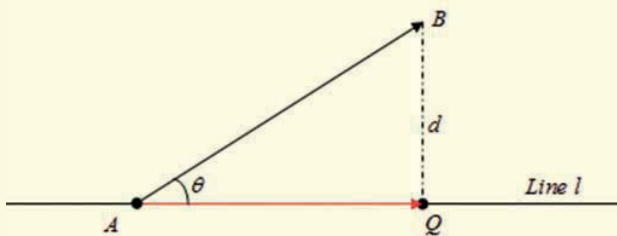

- Express d in terms of $\sin \theta$
- Multiply the right side containing $\sin \theta$, in the expression obtained in 1, by $\|\vec{u}\|$ on numerator and denominator. Deduce the new expression for d using cross product.

There are many methods used to find the distance between point $B(b_1, b_2, b_3)$ and a line passing through point $A(a_1, a_2, a_3)$ with direction vector $\vec{u} = (c_1, c_2, c_3)$.

Consider the following figure:

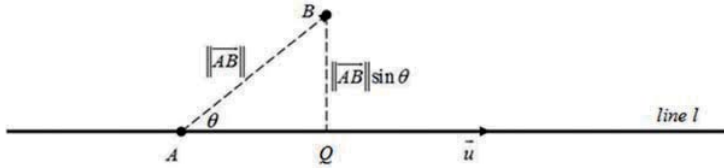

From Activity 8.9, the distance from point $B(b_1, b_2, b_3)$ to the line passing through point $A(a_1, a_2, a_3)$ with direction vector

$$\vec{u} = (c_1, c_2, c_3) \text{ is } \frac{\|\overrightarrow{AB} \times \vec{u}\|}{\|\vec{u}\|}.$$

Example 8.16

Find the distance from the point $Q(1, 3, -2)$ to the line given by the parametric equations:

$$\begin{cases} x = 2 + t \\ y = -1 - t \\ z = 3 + 2t \end{cases}$$

Solution

From the parametric equations, we know the direction vector, $\vec{u} = (1, -1, 2)$ and if we let $t = 0$, a point P on the line is $P(2, -1, 3)$.

$$\text{Thus, } \overrightarrow{PQ} = (1 - 2, 3 - (-1), -2 - 3) = (-1, 4, -5)$$

Find the cross product:

$$\overrightarrow{PQ} \times \vec{u} = \begin{vmatrix} \vec{i} & \vec{j} & \vec{k} \\ -1 & 4 & -5 \\ 1 & -1 & 2 \end{vmatrix} = 3\vec{i} - 3\vec{j} - 3\vec{k}$$

Using the distance formula:

$$D = \frac{\left\| \overrightarrow{PQ} \times \vec{u} \right\|}{\left\| \vec{u} \right\|}$$

$$= \frac{\sqrt{3^2 + (-3)^2 + (3)^2}}{\sqrt{1^2 + (-1)^2 + 2^2}} = \frac{3\sqrt{3}}{2} \text{ units}$$

Application Activity 8.9

Find the distance from the point to the line

- $(0, 0, 12)$; $x = 4t$, $y = -2t$, $z = 2t$
- $(2, 1, 3)$; $x = 2 + 2t$, $y = 1 + 6t$, $z = 3$
- $(3, -1, 4)$; $x = 4 - t$, $y = 3 + 2t$, $z = -5 + 3t$
- $(1, 3, -2)$; $\begin{cases} x = 2 + 3\lambda \\ y = -1 + \lambda \\ z = 1 - 2\lambda \end{cases}$
- $(1, 2, 3)$; $\frac{x-2}{4} = \frac{y-3}{4} = \frac{z-4}{2}$

8.2.6. Shortest distance between two skew lines

Activity 8.10



Consider the lines $L_1: \frac{x+7}{3} = \frac{y+4}{4} = \frac{z+3}{-2}$ and
 $L_2: \frac{x-21}{6} = \frac{y+5}{-4} = \frac{z-2}{-1}$

- Show that these lines are skew.
- Find the vector perpendicular to both lines and its normalized vector.
- Find one point on first and another point on second line. Find the vector joining these points.
- Find the scalar product of the normalized vector obtained in 2 and the vector obtained in 3.

One of the methods of finding this shortest distance is to write the parametric form of any point of each given line. Next, find the vector joining the points in parametric form which will be the vector in the direction of the common perpendicular of both lines. Now, the dot product of this vector and the direction vector of each line must be zero. This will help us to find the value of parameters and hence two points (one on the first line and another on the second line). The common perpendicular of the two lines passes through these two points. Then, the distance between these two points is the required shortest distance between the two lines. Using this method, we can find the equation of the common perpendicular since we have two points where this common perpendicular passes.

Note that if two lines intersect, the shortest distance is zero.

Example 8.17

Find the shortest distance between the lines:

$$\frac{x}{1} = \frac{y-3}{1} = \frac{z}{-1} \quad \text{and} \quad \frac{x-5}{3} = \frac{y-8}{7} = \frac{z-2}{-1}.$$

Solution

The direction vectors are $\vec{u} = (1, 1, -1)$ and $\vec{v} = (3, 7, -1)$

Check if the lines are skew: $\vec{u} \neq k\vec{v}$

$$\begin{cases} r = 5 + 3t \\ 3 + r = 8 + 7t \\ -r = 2 - t \end{cases}$$

First and last equations:

$$\begin{cases} r = 5 + 3t \\ -r = 2 - t \end{cases}$$

$$0r = 7 + 2t \Rightarrow t = -\frac{7}{2} \quad \text{and} \quad r = -\frac{11}{2}$$

Into the second:

$$3 - \frac{11}{2} = 8 - \frac{49}{2}$$

$$\Leftrightarrow -\frac{5}{2} = -\frac{33}{2} \quad \text{false}$$

Then, the two lines are skew.

Now, we require the vector perpendicular to both vectors.

$$\begin{aligned} \text{Using } \vec{w} = \vec{u} \times \vec{v} &= \begin{vmatrix} \vec{i} & \vec{j} & \vec{k} \\ 1 & 1 & -1 \\ 3 & 7 & -1 \end{vmatrix} \\ &= 6\vec{i} - 2\vec{j} + 4\vec{k} \end{aligned}$$

We obtain the common perpendicular vector $\vec{w} = (6, -2, 4)$ or $\vec{w} = (3, -1, 2)$.

Or

$$\begin{cases} p + q - r = 0 \\ 3p + 7q - r = 0 \end{cases}$$

Let $r = 1$ (do not take the value which will lead to the trivial solution), we have

$$\begin{cases} p + q = 1 \\ 3p + 7q = 1 \end{cases}$$

$$\Leftrightarrow \begin{cases} -3p - 3q = -3 \\ 3p + 7q = 1 \end{cases}$$

$$4q = -2 \Rightarrow q = -\frac{1}{2}$$

$$p = 1 - q = 1 + \frac{1}{2} = \frac{3}{2}$$

We have the vector $\left(\frac{3}{2}, -\frac{1}{2}, 1\right)$ or $2\left(\frac{3}{2}, -\frac{1}{2}, 1\right) = (3, -1, 2)$

since scalar multiple vectors are parallel. Then the common perpendicular is the vector $\vec{w} = (3, -1, 2)$

The normalized vector of \vec{w} in the same direction is

$$\left(\frac{3}{\sqrt{14}}, -\frac{1}{\sqrt{14}}, \frac{2}{\sqrt{14}}\right)$$

Next, we have point $(0, 3, 0)$ on first line and $(5, 8, 2)$ on second line.

The vector joining these points is $(5, 5, 2)$ and now the scalar product of this vector with the normalized vector of the common perpendicular is

$$\begin{aligned} \frac{15}{\sqrt{14}} - \frac{5}{\sqrt{14}} + \frac{4}{\sqrt{14}} &= \frac{14}{\sqrt{14}} \\ &= \sqrt{14} \end{aligned}$$

and this is the shortest distance required.

Alternative method

To find the distance, do the following:

Any point on first line is $(r, 3+r, -r)$ and any point on the second line is $(5+3t, 8+7t, 2-t)$

The vector joining these points is $(5+3t-r, 8+7t-3-r, 2-t+r)$

or $\vec{w} = (5+3t-r, 5+7t-r, 2-t+r)$

Now,

$$\vec{u} \cdot \vec{w} = 0 \text{ and } \vec{v} \cdot \vec{w} = 0$$

$$\begin{cases} 5+3t-r+5+7t-r-2+t-r=0 \\ 15+9t-3r+35+49t-7r-2+t-r=0 \end{cases}$$

$$\begin{cases} 11t-3r+8=0 \\ 59t-11r+48=0 \end{cases} \Rightarrow \begin{cases} t=-1 \\ r=-1 \end{cases}$$

Now, the points on two lines where the common perpendicular passes are $(-1, 2, 1)$ and $(2, 1, 3)$. The distance between these points is the required distance.

That is, the required distance is $\sqrt{3^2+1^2+2^2} = \sqrt{14}$.

The equation of the common perpendicular:

Since the common perpendicular passes through $(-1, 2, 1)$ and $(2, 1, 3)$, its direction vector is $\vec{w} = (3, -1, 2)$. The equations are

$$\begin{cases} x = -1 + 3r \\ y = 2 - r \\ z = 1 + 2r \end{cases}$$

Example 8.18

Find the equations to the common perpendicular to the following skew lines $\frac{x-5}{3} = \frac{y-7}{-16} = \frac{z-3}{7}$ and $\frac{x-9}{3} = \frac{y-13}{8} = \frac{z-15}{-5}$ and the shortest distance.

Solution

Direction vectors are $\vec{u} = (3, -16, 7)$ and $\vec{v} = (3, 8, -5)$

Any point on first line is $(5+3r, 7-16r, 3+7r)$ and any point on the second line is $(9+3t, 13+8t, 15-5t)$

The vector joining these two points is

$$\vec{w} = (9 + 3t - 5 - 3r, 13 + 8t - 7 - 16r, 15 - 5t - 3 - 7r)$$

$$\text{or } \vec{w} = (4 + 3t - 3r, 6 + 8t + 16r, 12 - 5t - 7r)$$

Now,

$$\vec{u} \cdot \vec{w} = 0 \quad \text{and} \quad \vec{v} \cdot \vec{w} = 0$$

$$\begin{cases} 12 + 9t - 9r - 96 - 128t - 256r + 84 - 35t - 49r = 0 \\ 12 + 9t - 9r + 48 + 64t + 128r - 60 + 25t + 35r = 0 \end{cases}$$

$$\begin{cases} -154t - 314r = 0 \\ 98t + 154r = 0 \end{cases} \Rightarrow \begin{cases} t = 0 \\ r = 0 \end{cases}$$

Now, the points on two lines where the common perpendicular passes are $(5, 7, 3)$ and $(9, 13, 15)$.

Since the common perpendicular passes through $(5, 7, 3)$ and $(9, 13, 15)$, its direction vector is $\vec{w} = (4, 6, 12)$ or $\vec{w} = (2, 3, 6)$. The equations are

$$\begin{cases} x = 5 + 2r \\ y = 7 + 3r \\ z = 3 + 6r \end{cases}$$

$$\text{The length is } \sqrt{(9-5)^2 + (13-7)^2 + (15-3)^2} = 14$$



Notice

Finding shortest distance using box product

Consider two skew lines $L_1: \vec{r} = \vec{a} + \lambda\vec{u}$ and $L_2: \vec{r} = \vec{b} + \lambda\vec{v}$.

If P and Q are the points, one on each line, which are closest together, then, \overline{PQ} is perpendicular to both lines and hence parallel to $\vec{w} = \vec{u} \times \vec{v}$.

The shortest distance is then $\|\overline{PQ}\|$ which is the projection of \overline{AB} on \vec{w} .

Thus, the shortest distance between two points, one on each

$$\text{line, is given by } \|\overline{PQ}\| = \frac{\|\vec{ab} \cdot \vec{w}\|}{\|\vec{w}\|} = \frac{\|(\vec{b} - \vec{a}) \cdot \vec{u} \times \vec{v}\|}{\|\vec{w}\|}$$

Example 8.19

Find the shortest distance between the skew lines
 $L_1 : \vec{r} = 5\vec{i} + 3\vec{j} + \lambda(2\vec{i} - \vec{j})$ and $L_2 : \vec{r} = 2\vec{i} + 9\vec{k} + \mu(\vec{j} - \vec{k})$.

Solution

$$\|\overline{PQ}\| = \frac{\|\vec{ab} \cdot \vec{w}\|}{\|\vec{w}\|} = \frac{\|(\vec{b} - \vec{a}) \cdot \vec{u} \times \vec{v}\|}{\|\vec{w}\|}$$

Here $\vec{u} = 5\vec{i} + 3\vec{j}$ and $\vec{v} = 2\vec{i} + 9\vec{k}$ which are direction vectors of L_1 and L_2 respectively.

$$\vec{w} = \vec{u} \times \vec{v} = \begin{vmatrix} \vec{i} & \vec{j} & \vec{k} \\ 5 & 3 & 0 \\ 2 & 0 & 9 \end{vmatrix} = \vec{i} + 2\vec{j} + 2\vec{k}$$

$$\vec{ab} = 2\vec{i} + 9\vec{k} - (5\vec{i} + 3\vec{j}) = -3\vec{i} - 3\vec{j} + 9\vec{k} = -3(\vec{i} + \vec{j} - 3\vec{k})$$

So the distance is

$$\begin{aligned} \|\overline{PQ}\| &= \frac{\|(\vec{b} - \vec{a}) \cdot \vec{u} \times \vec{v}\|}{\|\vec{w}\|} \\ \|\overline{PQ}\| &= \frac{\|-3(\vec{i} + \vec{j} - 3\vec{k}) \cdot (\vec{i} + 2\vec{j} + 2\vec{k})\|}{\|\vec{i} + 2\vec{j} + 2\vec{k}\|} \\ &= \frac{3\|1 + 2 - 6\|}{\sqrt{1 + 4 + 4}} = 3 \end{aligned}$$

Application Activity 8.10

Find the shortest distance between the lines:

$$1. L_1 \equiv \begin{cases} x = 1 + 4t \\ y = 5 - 4t \\ z = -1 + 5t \end{cases} \quad L_2 \equiv \begin{cases} x = 2 + 8t \\ y = 4 - 3t \\ z = 5 + t \end{cases}$$

$$2. L_1 \equiv \begin{cases} x = 3 + 2t \\ y = -2t \\ z = 4 - t \end{cases} \quad L_2 \equiv \begin{cases} x = 4 - t \\ y = 3 + 5t \\ z = 2 - t \end{cases}$$

$$3. L \equiv \frac{x+8}{2} = \frac{y-10}{3} = \frac{z-6}{1} \quad M \equiv \frac{x-1}{-1} = \frac{y-1}{2} = \frac{z-1}{4}$$

8.3. Planes in 3 dimensions

8.3.1. Equations of planes

In space, a plane is determined by a point and two direction vectors which form a basis (linearly independent vectors).

We will denote planes by Greek letters such as $\alpha, \beta, \gamma, \dots$

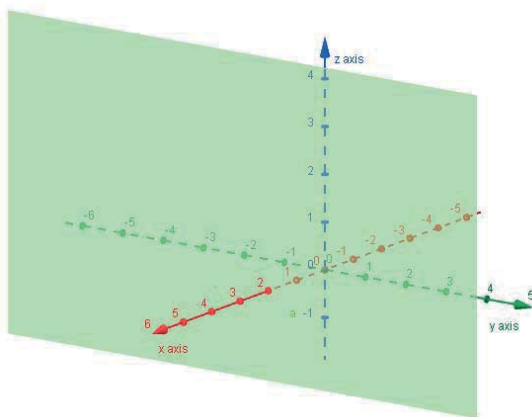

a) Plane defined by a position vector and two direction vectors



Activity 8.1 I

Let $P(x_0, y_0, z_0)$ be a point on a plane and $\vec{u} = (x_1, y_1, z_1)$
 $\vec{v} = (x_2, y_2, z_2)$ be its two direction vectors. If $X(x, y, z)$ define
 any point on this plane.

1. Write down the vector equation of this plane. Use parameter r for direction vector \vec{u} and s for direction vector \vec{v} .
2. Equate each of the components to obtain parametric equations.
3. Find the following determinant to obtain the Cartesian equations

$$\begin{vmatrix} x - x_0 & x_1 & x_2 \\ y - y_0 & y_1 & y_2 \\ z - z_0 & z_1 & z_2 \end{vmatrix} = 0$$

From Activity 8.11, the plane containing point $P(x_0, y_0, z_0)$ with $\vec{u} = (x_1, y_1, z_1)$, $\vec{v} = (x_2, y_2, z_2)$ as two independent direction vectors and $X(x, y, z)$ any point on this plane, has

Vector equation $\overrightarrow{PX} = r\vec{u} + s\vec{v}$ where r and s are parameters.

Parametric equations

$$\begin{cases} x = x_0 + rx_1 + sx_2 \\ y = y_0 + ry_1 + sy_2 \\ z = z_0 + rz_1 + sz_2 \end{cases}$$

Cartesian equation

$$\begin{vmatrix} x - x_0 & x_1 & x_2 \\ y - y_0 & y_1 & y_2 \\ z - z_0 & z_1 & z_2 \end{vmatrix} = 0$$

We can also find the Cartesian equation by the following determinant:

$$\begin{vmatrix} x & x_0 & x_1 & x_2 \\ y & y_0 & y_1 & y_2 \\ z & z_0 & z_1 & z_2 \\ 1 & 1 & 0 & 0 \end{vmatrix} = 0$$

The Cartesian equation of plane can be written in the form $a(x - x_0) + b(y - y_0) + c(z - z_0) = 0$. This Cartesian equation is called the scalar equation or standard form of the equation for the plane.

We can also find the Cartesian equation by finding the value of two parameters in the first two equations of parametric equations and put them in the third equation.

Example 8.20

Find vector, parametric and Cartesian equations of the plane, α , passing through the point $A(2, 7, -1)$ with direction vectors $\vec{u} = (3, 1, 1)$ and $\vec{v} = (-1, -2, -3)$.

Solution

Let $P(x, y, z)$ represent any point of plane α . r and s be the parameters.

The vector equation is $\alpha \equiv \overrightarrow{AP} = r\vec{u} + s\vec{v}$

Or

$$\alpha \equiv \overrightarrow{OX} = \overrightarrow{OP} + r\vec{u} + s\vec{v}$$

Or

$$\begin{pmatrix} x \\ y \\ z \end{pmatrix} = \begin{pmatrix} 2 \\ 7 \\ -1 \end{pmatrix} + r \begin{pmatrix} 3 \\ 1 \\ 1 \end{pmatrix} + s \begin{pmatrix} -1 \\ -2 \\ -3 \end{pmatrix}$$

Or

$$x \vec{i} + y \vec{j} + z \vec{k} = 2 \vec{i} + 7 \vec{j} - \vec{k} + r(3 \vec{i} + \vec{j} + \vec{k}) + s(-\vec{i} - 2\vec{j} - 3\vec{k})$$

Parametric equations:

$$\alpha \equiv \begin{cases} x = 2 + 3r - s \\ y = 7 + r - 2s \\ z = -1 + r - 3s \end{cases}$$

Cartesian equations:

From the parametric equations, use the first two equations to find the values of the parameters r and s

$$\begin{cases} x = 2 + 3r - s & \times -2 \\ y = 7 + r - 2s \end{cases}$$

$$\Rightarrow \begin{cases} -2x = -4 - 6r + 2s \\ y = 7 + r - 2s \end{cases}$$

$$-2x + y = 3 - 5r \Rightarrow r = \frac{2x - y + 3}{5}$$

$$s = -x + 2 + 3r$$

$$\Leftrightarrow s = -x + 2 + 3\left(\frac{2x - y + 3}{5}\right)$$

$$\Leftrightarrow s = \frac{-5x + 10 + 6x - 3y + 9}{5}$$

$$\Leftrightarrow s = \frac{x - 3y + 19}{5}$$

Now, replace those values of s and r in the third equation:

$$z = -1 + \frac{2x - y + 3}{5} - \frac{3x - 9y + 57}{5}$$

$$z = \frac{-5 + 2x - y + 3 - 3x + 9y - 57}{5}$$

$$\Leftrightarrow z = \frac{-x + 8y - 59}{5}$$

And finally we have the Cartesian equation

$$\alpha \equiv x - 8y + 5z + 59 = 0$$

Alternative method for determining Cartesian equation:

To find the Cartesian equation, determine the following determinant

$$\alpha \equiv \begin{vmatrix} x-2 & 3 & -1 \\ y-7 & 1 & -2 \\ z+1 & 1 & -3 \end{vmatrix} = 0$$

$$\Leftrightarrow (x-2)(-3) + (y-7)(-1) + (z+1)(-6) + (z+1) + 2(x-2) + 9(y-7) = 0$$

$$\Leftrightarrow -3x + 6 - y + 7 - 6z - 6 + z + 1 + 2x - 4 + 9y - 63 = 0$$

$$\Leftrightarrow -x + 8y - 5z - 59 = 0$$

And finally,

$$\alpha \equiv x - 8y + 5z + 59 = 0$$

Other method for finding Cartesian equation:

$$\begin{vmatrix} x & 2 & 3 & -1 \\ y & 7 & 1 & -2 \\ z & -1 & 1 & -3 \\ 1 & 1 & 0 & 0 \end{vmatrix} = 0$$

Let the 4th row be fixed:

$$\Leftrightarrow -1 \begin{vmatrix} 2 & 3 & -1 \\ 7 & 1 & -2 \\ -1 & 1 & -3 \end{vmatrix} + 1 \begin{vmatrix} x & 3 & -1 \\ y & 1 & -2 \\ z & 1 & -3 \end{vmatrix} - 0 \begin{vmatrix} x & 2 & -1 \\ y & 7 & -2 \\ z & -1 & -3 \end{vmatrix} + 0 \begin{vmatrix} x & 2 & 3 \\ y & 7 & 1 \\ z & -1 & 1 \end{vmatrix} = 0$$

$$\Leftrightarrow -(-6 - 7 + 6 - 1 + 4 + 63) + (-3x - y - 6z + z + 2x + 9y) = 0$$

$$\Leftrightarrow -59 - x + 8y - 5z = 0$$

And finally,

$$\alpha \equiv x - 8y + 5z + 59 = 0$$

Application Activity 8.11

Find vector, parametric and Cartesian equations of the plane, α ,

1. passing through the point $A(2,4,1)$ with direction vectors $\vec{u} = (1,3,-1)$ and $\vec{v} = (2,1,3)$.
2. passing through the point $A(1,1,1)$ with direction vectors $\vec{u} = (4,-2,1)$ and $\vec{v} = (-2,4,3)$.
3. passing through the point $A(3,6,0)$ with direction vectors $\vec{u} = (1,0,1)$ and $\vec{v} = (5,1,7)$.
4. passing through the point $A(4,3,8)$ with direction vectors $\vec{u} = (-4,1,1)$ and $\vec{v} = (-2,8,6)$.

b) Plane defined by two position vectors and a direction vector

**Activity 8.12**

Let $P(x_0, y_0, z_0)$ and $Q(x_1, y_1, z_1)$ be two points of a plane whose direction vector is $\vec{v} = (x_2, y_2, z_2)$.

1. Write down the vector equation of this plane. Use \overrightarrow{PQ} as second direction vector and P as starting point. Also use $X(x, y, z)$ as any point of the plane and r, s as parameters.
2. Equate each components to obtain parametric equations
3. Find the following determinant to obtain the Cartesian equation

$$\begin{vmatrix} x - x_0 & x_1 - x_0 & x_2 \\ y - y_0 & y_1 - y_0 & y_2 \\ z - z_0 & z_1 - z_0 & z_2 \end{vmatrix} = 0$$

From Activity 8.12, a plane passing through points $P(x_0, y_0, z_0)$ and $Q(x_1, y_1, z_1)$ with direction vector $\vec{v} = (x_2, y_2, z_2)$ and $X(x, y, z)$ being any point, has

Vector equation $\overrightarrow{PX} = r\overrightarrow{PQ} + s\vec{v}$ where r and s are parameters

Parametric equations

$$\begin{cases} x = x_0 + r(x_1 - x_0) + sx_2 \\ y = y_0 + r(y_1 - y_0) + sy_2 \\ z = z_0 + r(z_1 - z_0) + sz_2 \end{cases}$$

Cartesian equation

$$\begin{vmatrix} x - x_0 & x_1 - x_0 & x_2 \\ y - y_0 & y_1 - y_0 & y_2 \\ z - z_0 & z_1 - z_0 & z_2 \end{vmatrix} = 0$$

Or we can use the determinant

$$\begin{vmatrix} x & x_0 & x_1 & x_2 \\ y & y_0 & y_1 & y_2 \\ z & z_0 & z_1 & z_2 \\ 1 & 1 & 1 & 0 \end{vmatrix} = 0$$

We can also find the Cartesian equation by finding the value of two parameters in first two equations of parametric equations and put them in the third equation.

Example 8.21

Find the vector, parametric and Cartesian equation of plane β containing points $A(3, -2, -1)$ and $B(4, 2, 7)$ with direction vector $\vec{u} = (1, 1, 3)$.

Solution

One of the direction vectors is $\overrightarrow{AB} = (1, 4, 8)$

The vector equation:

Let $X(x, y, z)$ be any point on the plane

$\overrightarrow{AX} = r\overrightarrow{AB} + t\vec{u}$ or $\overrightarrow{OX} = \overrightarrow{OA} + r\overrightarrow{AB} + t\vec{u}$ with $O(0, 0, 0)$, r and t are parameters

Parametric equations:

$$\begin{cases} x = 3 + r + t \\ y = -2 + 4r + t \\ z = -1 + 8r + 3t \end{cases}$$

Cartesian equation:

$$\begin{cases} x = 3 + r + t \\ y = -2 + 4r + t \end{cases} \Rightarrow \begin{cases} r = \frac{-x + y + 5}{3} \\ t = \frac{4x - y - 14}{3} \end{cases}$$

$$z = -1 + 8\left(\frac{-x + y + 5}{3}\right) + 3\left(\frac{4x - y - 14}{3}\right)$$

$$\Leftrightarrow z = \frac{-3 - 8x + 8y + 40 + 12x - 3y - 42}{3}$$

$$\Leftrightarrow z = \frac{4x + 5y - 5}{3}$$

And finally,

$$\beta \equiv 4x + 5y - 3z - 5 = 0$$

Or use the determinant

$$\begin{vmatrix} x & 3 & 1 & 1 \\ y & -2 & 4 & 1 \\ z & -1 & 8 & 3 \\ 1 & 1 & 0 & 0 \end{vmatrix} = 0$$

Let the 4th row be fixed:

$$\Leftrightarrow -1 \begin{vmatrix} 3 & 1 & 1 \\ -2 & 4 & 1 \\ -1 & 8 & 3 \end{vmatrix}$$

$$+1 \begin{vmatrix} x & 1 & 1 \\ y & 4 & 1 \\ z & 8 & 3 \end{vmatrix} - 0 + 0 = 0$$

$$\Leftrightarrow -(36 - 16 - 1 + 4 - 24 + 6)$$

$$+(12x + 8y + z - 4z - 8x - 3y) \Rightarrow -5 + 4x + 5y - 3z = 0$$

$$= 0$$

$$\Leftrightarrow -1 \begin{vmatrix} 3 & 4 & 1 \\ -2 & 2 & 1 \\ -1 & 7 & 3 \end{vmatrix} + 1 \begin{vmatrix} x & 4 & 1 \\ y & 2 & 1 \\ z & 7 & 3 \end{vmatrix} - 0 + 0 = 0$$

$$\Leftrightarrow -(18 - 14 - 4 + 2 - 21 + 24) + (6x + 7y + 4z - 2z - 7x - 12y) = 0$$

$$\Leftrightarrow -5 + 4x + 5y - 3z = 0$$

And finally,

$$\beta \equiv 4x + 5y - 3z - 5 = 0$$

Or

$$\begin{vmatrix} x-3 & 1 & 1 \\ y+2 & 4 & 1 \\ z+1 & 8 & 3 \end{vmatrix} = 0$$

$$\Leftrightarrow 12x - 36 + 8y + 16 + z + 1 - 4z - 4 - 8x + 24 - 3y - 6 = 0$$

And finally,

$$\beta \equiv 4x + 5y - 3z - 5 = 0$$

Application Activity 8.12

Find the vector, parametric and Cartesian equation of plane β

1. Containing points $A(2,4,1)$ and $B(2,1,3)$ with direction vector $\vec{u} = (1,3,-1)$
2. Containing points $A(2,1,-1)$ and $B(2,1,3)$ with direction vector $\vec{u} = (-1,2,1)$.
3. Containing points $A(1,1,1)$ and $B(-2,4,3)$ with direction vector $\vec{u} = (4,-2,1)$.
4. Containing points $A(3,6,0)$ and $B(5,1,7)$ with direction vector $\vec{u} = (1,0,1)$.

c) Plane defined by three position vectors

Activity 8.13



Let $P(x_0, y_0, z_0)$, $Q(x_1, y_1, z_1)$ and $N(x_2, y_2, z_2)$ be three points of a plane.

1. Write down the vector equation of this plane. Use \overrightarrow{PQ} and \overrightarrow{PN} as two direction vectors and P as starting point. Also use $X(x, y, z)$ as any point of the plane and r, s as parameters.
2. Equate each of the components to obtain parametric equations.
3. Find the following determinant to obtain the Cartesian equation

$$\begin{vmatrix} x - x_0 & x_1 - x_0 & x_2 - x_0 \\ y - y_0 & y_1 - y_0 & y_2 - y_0 \\ z - z_0 & z_1 - z_0 & z_2 - z_0 \end{vmatrix} = 0$$

From Activity 8.13, a plane passing through points $P(x_0, y_0, z_0)$, $Q(x_1, y_1, z_1)$ and $N(x_2, y_2, z_2)$ and $X(x, y, z)$ any point, has

Vector equation $\overrightarrow{PX} = r\overrightarrow{PQ} + s\overrightarrow{PN}$ where r and s are parameters

Parametric equations

$$\begin{cases} x = x_0 + r(x_1 - x_0) + s(x_2 - x_0) \\ y = y_0 + r(y_1 - y_0) + s(y_2 - y_0) \\ z = z_0 + r(z_1 - z_0) + s(z_2 - z_0) \end{cases}$$

Cartesian equation

$$\begin{vmatrix} x - x_0 & x_1 - x_0 & x_2 - x_0 \\ y - y_0 & y_1 - y_0 & y_2 - y_0 \\ z - z_0 & z_1 - z_0 & z_2 - z_0 \end{vmatrix} = 0$$

Or we can use the determinant

$$\begin{vmatrix} x & x_0 & x_1 & x_2 \\ y & y_0 & y_1 & y_2 \\ z & z_0 & z_1 & z_2 \\ 1 & 1 & 1 & 1 \end{vmatrix} = 0$$

We can also find the Cartesian equation by finding the value of two parameters in the first two equations of parametric equations and put them in the third equation.

Example 8.22

Find vector, parametric and Cartesian equation of plane β passing through points $A(1,3,5)$, $B(-2,5,4)$ and $C(3,-6,-5)$.

Solution

Let A be the starting point. Then, the two direction vectors are $\overrightarrow{AB} = (-3, 2, -1)$ and $\overrightarrow{AC} = (2, -9, -10)$.

Let $X(x, y, z)$ represent any point on this plane, then,

Vector equation is $\beta \equiv \overrightarrow{AX} = r\overrightarrow{AB} + s\overrightarrow{AC}$ r and s are parameters.

Parametric equations

$$\beta \equiv \begin{cases} x = 1 - 3r + 2s \\ y = 3 + 2r - 9s \\ z = 5 - r - 10s \end{cases}$$

Cartesian equation

$$\begin{cases} x = 1 - 3r + 2s & \times 2 \\ y = 3 + 2r - 9s & \times 3 \end{cases}$$

$$\Rightarrow \begin{cases} 2x = 2 - 6r + 4s \\ 3y = 9 + 6r - 27s \end{cases}$$

$$2x + 3y = 11 - 23s \Rightarrow s = \frac{11 - 2x - 3y}{23}$$

$$y = 3 + 2r - 9s$$

$$\Leftrightarrow y = 3 + 2r - 9\left(\frac{11 - 2x - 3y}{23}\right)$$

$$\Leftrightarrow 23y = 69 + 46r - 99 + 18x + 27y$$

$$-46r = 18x + 4y - 30$$

$$\Leftrightarrow r = \frac{-9x - 2y + 15}{23}$$

Now,

$$z = 5 - \left(\frac{-9x - 2y + 15}{23}\right) - 10\left(\frac{11 - 2x - 3y}{23}\right)$$

$$\Leftrightarrow 23z = 115 + 9x + 2y - 15 - 110 + 20x + 30y$$

$$\Leftrightarrow 29x + 32y - 23z - 10 = 0$$

Then the Cartesian equation is

$$\beta \equiv 29x + 32y - 23z - 10 = 0$$

Or we can use the determinant:

$$\beta \equiv \begin{vmatrix} x-1 & -3 & 2 \\ y-3 & 2 & -9 \\ z-5 & -1 & -10 \end{vmatrix} = 0$$

$$(x-1)(-20) + (y-3)(-2) + (z-5)27 - (z-5)4 - (x-1)9 - (y-3)30 = 0$$

$$\Leftrightarrow -20x + 20 - 2y + 6 + 27z - 135 - 4z + 20 - 9x + 9 - 30y + 90 = 0$$

$$\Leftrightarrow -29x - 32y + 23z + 10 = 0$$

Then, $\beta \equiv 29x + 32y - 23z - 10 = 0$

Or we can use the determinant

$$\beta \equiv \begin{vmatrix} x & 1 & -2 & 3 \\ y & 3 & 5 & -6 \\ z & 5 & 4 & -5 \\ 1 & 1 & 1 & 1 \end{vmatrix} = 0$$

Let us fix the first column

$$x \begin{vmatrix} 3 & 5 & -6 \\ 5 & 4 & -5 \\ 1 & 1 & 1 \end{vmatrix} - y \begin{vmatrix} 1 & -2 & 3 \\ 5 & 4 & -5 \\ 1 & 1 & 1 \end{vmatrix} + z \begin{vmatrix} 1 & -2 & 3 \\ 3 & 5 & -6 \\ 1 & 1 & 1 \end{vmatrix} - 1 \begin{vmatrix} 1 & -2 & 3 \\ 3 & 5 & -6 \\ 5 & 4 & -5 \end{vmatrix} = 0$$

$$\Leftrightarrow x(12 - 30 - 25 + 24 + 15 - 25) - y(4 + 15 + 10 - 12 + 5 + 10) +$$

$$z(5 + 9 + 12 - 15 + 6 + 6) - (-25 + 36 + 60 - 75 + 24 - 30) = 0$$

$$\Leftrightarrow -29x - 32y + 23z + 10 = 0$$

Then,

$$\beta \equiv 29x + 32y - 23z - 10 = 0$$

Example 8.23

Given the point $A(1,1,1), B(2,3,4), C(3,-1,4), P(3,0,-3)$ and $Q(5,1,-6)$. The coordinates of point M which belongs to the plane ABC and on line PQ are to be determined in as many ways as possible.

- a) Write the parametric equations of plane ABC and the line PQ. Deduce the values for which the point M lies in both the plane and the line.
- b) Write Cartesian equations of plane ABC and of line PQ. Deduce the coordinate of M .

Solution

a) Direction vectors of the plane ABC are

$\overrightarrow{AB} = (1, 2, 3), \overrightarrow{AC} = (2, -2, 3)$ where A is the starting point.

The direction vector of line PQ is $\overrightarrow{PQ} = (2, 1, -3)$ where P is the starting point.

The parametric equations of plane ABC are

$$ABC \equiv \begin{cases} x = 1 + r + 2t \\ y = 1 + 2r - 2t \\ z = 1 + 3r + 3t \end{cases}$$

where r and t are parameters.

The parametric equations of line PQ are

$$\begin{cases} x = 3 + 2s \\ y = s \\ z = -3 - 3s \end{cases} \quad \text{where } s \text{ is a parameter.}$$

Point M lies on plane ABC and on line PQ, then we need to equate the parametric equations of plane ABC and line PQ. That is;

$$\begin{cases} 1 + r + 2t = 3 + 2s \\ 1 + 2r - 2t = s \\ 1 + 3r + 3t = -3 - 3s \end{cases} \Leftrightarrow \begin{cases} r + 2t - 2s = 2 \\ 2r - 2t - s = -1 \\ 3r + 3t + 3s = -4 \end{cases}$$

Taking the first equation: $r + 2t - 2s = 2 \Rightarrow r = 2 - 2t + 2s$.

Putting this value into the two others, we have

$$\begin{cases} 4 - 4t + 4s - 2t - s = -1 \\ 6 - 6t + 6s + 3t + 3s = -4 \end{cases}$$

$$\Leftrightarrow \begin{cases} -6t + 3s = -5 \\ -3t + 9s = -10 \end{cases} \Leftrightarrow \begin{cases} -6t + 3s = -5 \\ \underline{6t - 18s = 20} \end{cases}$$

$$-15s = 15 \Rightarrow s = -1$$

$$-6t = -5 - 3s = -5 + 3 = -2 \Rightarrow t = \frac{1}{3}$$

$$r = 2 - 2t + 2s = 2 - \frac{2}{3} - 2 = -\frac{2}{3}$$

Thus, the values of parameters for point M to lie on both plane and line are

$$\begin{cases} r = -\frac{2}{3} \\ t = \frac{1}{3} \\ s = -1 \end{cases}$$

Back to the parametric equations, we have

$$\begin{cases} x = 3 - 2 = 1 \\ y = -1 \\ z = -3 + 3 = 0 \end{cases}$$

Hence, the coordinates of M are $(1, -1, 0)$.

b) Cartesian equations of plane ABC

$$ABC \equiv \begin{vmatrix} x & 1 & 1 & 2 \\ y & 1 & 2 & -2 \\ z & 1 & 3 & 3 \\ 1 & 1 & 0 & 0 \end{vmatrix} = 0$$

$$ABC \equiv - \begin{vmatrix} 1 & 1 & 2 \\ 1 & 2 & -2 \\ 1 & 3 & 3 \end{vmatrix} + \begin{vmatrix} x & 1 & 2 \\ y & 2 & -2 \\ z & 3 & 3 \end{vmatrix} = 0$$

$$ABC \equiv -(6 + 6 - 2 - 4 + 6 - 3) + (6x + 6y - 2z - 4z + 6x - 3y) = 0$$

$$ABC \equiv 12x + 3y - 6z - 9 = 0$$

Cartesian equations of line

From parametric equations, eliminating the parameter gives:

$$\frac{x-3}{2} = y = \frac{z+3}{-3}$$

Coordinates of M:

From Cartesian equations of the line PQ, we have

$$x = 3 + 2y$$

$$z = \frac{3 - 3x}{2} = \frac{3 - 9 - 6y}{2} = -3 - 3y$$

Putting these values into the Cartesian equation of the plane ABC, we have

$$12(3 + 2y) + 3y - 6(-3 - 3y) - 9 = 0 \text{ which gives } y = -1 \text{ and then}$$

$$x = 3 + 2y = 3 - 2 = 1$$

$$z = -3 - 3y = -3 + 3 = 0$$

Hence, the coordinates of M are $(1, -1, 0)$

Application Activity 8.13

Find vector, parametric and Cartesian equation of plane β passing through points:

1. $A(2, 4, 1)$, $B(1, 3, -1)$ and $C(2, 1, 3)$.
2. $A(1, 1, 1)$, $B(4, -2, 1)$ and $C(-2, 4, 3)$.
3. $A(3, 6, 0)$, $B(1, 0, 1)$ and $C(5, 1, 7)$.
4. $A(4, 3, 8)$, $B(-4, 1, 1)$ and $C(-2, 8, 6)$.



Notice

General form of plane

As we have seen, the Cartesian equation of a plane has the form $ax + by + cz + d = 0$ with $(a, b, c) \neq (0, 0, 0)$ or we can write it as $ax + by + cz = k$. This equation is also called the scalar equation of the plane.

In the next sections, we will see how to find the Cartesian equation of a plane using its normal vector.

Now consider the Cartesian equation of a plane $ax + by + cz = k$ with $(a, b, c) \neq (0, 0, 0)$

Let us study different possible cases:

- ⊙ If $b = c = 0 \neq a$, the equation becomes $ax = k$ or $x = \frac{k}{a}$ which is the equation of plane parallel to the plane yz .
- ⊙ If $a = c = 0 \neq b$, the equation becomes $by = k$ or $y = \frac{k}{b}$ which is the equation of plane parallel to the plane xz .
- ⊙ Similarly, if $a = b = 0 \neq c$, the equation becomes $cz = k$ or $z = \frac{k}{c}$ which is the equation of plane parallel to the plane xy .

- ⊙ If $c = 0 \neq a, b$, the equation becomes $ax + by = k$ which is the equation of plane parallel to the z -axis.
- ⊙ If $b = 0 \neq a, c$, the equation becomes $ax + cz = k$ which is the equation of plane parallel to the y -axis.
- ⊙ Similarly, if $a = 0 \neq b, c$, the equation becomes $by + cz = k$ which is the equation of plane parallel to the x -axis.

In general, we can say that if in the general equation of plane, $ax + by + cz = k$, the coefficient of one unknown is zero, we have the equation of plane which is parallel to the axis corresponding to that unknown.

- ⊙ If all a, b, c are different from zero, the equation $ax + by + cz = k$ can be considered as Cartesian equation of plane passing through the point $\left(0, 0, \frac{k}{c}\right)$ and with direction vectors $(b, -a, 0)$ and $(c, 0, -a)$ Or

As Cartesian equation of plane passing through points $\left(\frac{k}{a}, 0, 0\right)$, $\left(0, \frac{k}{b}, 0\right)$ and $\left(0, 0, \frac{k}{c}\right)$. The above results can help us to sketch planes in space.

Example 8.24

Consider the following plane $\gamma \equiv 3x + 2y + 4z = 12$
 This plane passes through points: $\left(\frac{12}{3}, 0, 0\right)$, $\left(0, \frac{12}{2}, 0\right)$ and $\left(0, 0, \frac{12}{4}\right)$
 Or $(4, 0, 0)$, $(0, 6, 0)$ and $(0, 0, 3)$.

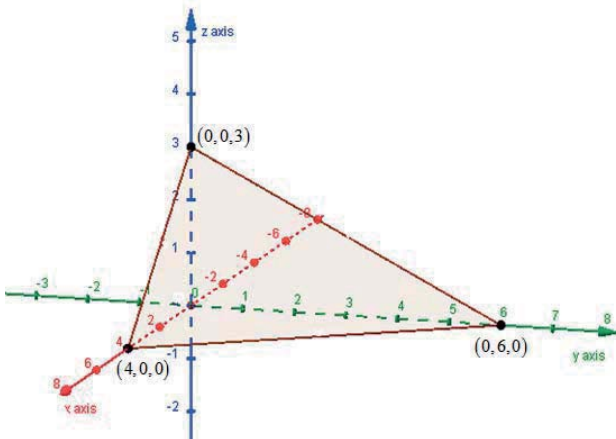

Example 8.25

Plane parallel to yz plane

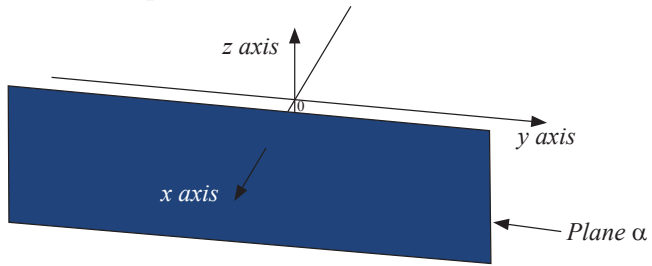

Example 8.26

Plane parallel to xz plane

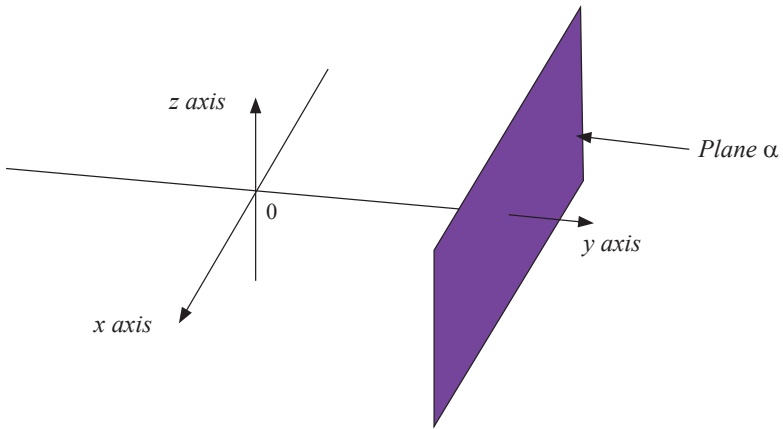

Example 8.27

Plane parallel to xy plane

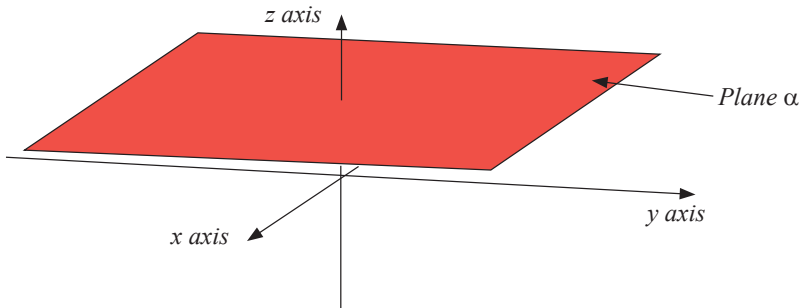

8.3.2. Condition of co-planarity of four points

Activity 8.14



From the equation of plane passing through the three given points, determine which of the following set of points lie on the same plane

1. $A = \{(1, 2, -1), (2, 3, 1), (3, -1, 0)\}$ and $\{(1, 2, 1)\}$

2. $B = \{(-2, 1, 1), (0, 2, 3), (1, 0, -1)\}$ and $\{(2, 1, -1)\}$

3. $C = \{(1, 0, -1), (0, 2, 3), (-2, 1, 1)\}$ and $\{(4, 2, 3)\}$

Is there any shortcut to verify if the given four points lie in the same plane?

If there is, indicate any.

Consider four points (a_1, a_2, a_3) ; (b_1, b_2, b_3) ; (c_1, c_2, c_3) and (d_1, d_2, d_3) . These points are coplanar (meaning that they lie on the same plane) if the following condition is satisfied.

$$\begin{vmatrix} a_1 & b_1 & c_1 & d_1 \\ a_2 & b_2 & c_2 & d_2 \\ a_3 & b_3 & c_3 & d_3 \\ 1 & 1 & 1 & 1 \end{vmatrix} = 0 \quad \text{or} \quad \begin{vmatrix} a_1 - d_1 & b_1 - d_1 & c_1 - d_1 \\ a_2 - d_2 & b_2 - d_2 & c_2 - d_2 \\ a_3 - d_3 & b_3 - d_3 & c_3 - d_3 \end{vmatrix} = 0$$

Example 8.28

Show that the points $(4, 0, 0)$, $(0, 6, 0)$, $(0, 0, 3)$ and $\left(1, \frac{9}{2}, 0\right)$ are coplanar.

Solution

$$\begin{vmatrix} 4 & 0 & 0 & 1 \\ 0 & 6 & 0 & \frac{9}{2} \\ 0 & 0 & 3 & 0 \\ 1 & 1 & 1 & 1 \end{vmatrix} \stackrel{?}{=} 0 \quad \text{or} \quad \begin{vmatrix} 4 & -1 & -1 \\ -6 & \frac{3}{2} & -\frac{9}{2} \\ 0 & 0 & 3 \end{vmatrix} = 0$$

Let the third row be fixed

$$\begin{vmatrix} 4 & 0 & 0 & 1 \\ 0 & 6 & 0 & \frac{9}{2} \\ 0 & 0 & 3 & 0 \\ 1 & 1 & 1 & 1 \end{vmatrix} = 0 \begin{vmatrix} 0 & 0 & 1 \\ 6 & 0 & \frac{9}{2} \\ 1 & 1 & 1 \end{vmatrix} - 0 \begin{vmatrix} 4 & 0 & 1 \\ 0 & 0 & \frac{9}{2} \\ 1 & 1 & 1 \end{vmatrix} + 3 \begin{vmatrix} 4 & 0 & 1 \\ 0 & 6 & \frac{9}{2} \\ 1 & 1 & 1 \end{vmatrix} - 0 \begin{vmatrix} 4 & 0 & 0 \\ 0 & 6 & 0 \\ 1 & 1 & 1 \end{vmatrix}$$

$$= 0 - 0 + 3(24 + 0 + 0 - 6 - 18)$$

$$= 0$$

Thus, the given points are coplanar.

Remark

Three distinct points are always coplanar, but a fourth point or more added in space can exist in another plane. So, if points are in a line, it is possible to put them on a plane, but there may be points on the plane that are not all in a straight line, thus collinear points are coplanar but coplanar points need not to be collinear.

Application Activity 8.14

- Determine if the points $A(1,2,3)$, $B(4,7,8)$, $C(3,5,5)$, $D(-1,-2,-3)$ and $E(2,2,2)$ are coplanar.
- Calculate the value of x for the coplanar set of points $A(0,0,1)$, $B(0,1,2)$, $C(-2,1,3)$ and $D(x,x-1,2)$.
- What is the condition for a, b and c so that the points $A(1,0,1)$, $B(1,1,0)$, $C(0,1,1)$ and $D(a,b,c)$ are coplanar?
- Calculate the value of a for the points $(a,0,1)$, $(0,1,2)$, $(1,2,3)$ and $(7,2,1)$ so that they are coplanar. Also, calculate the equation of the plane that contains them.

8.3.3. Position of a line and a plane

Activity 8.15



1. Let $\vec{u} = (a, b, c)$ be the direction vector of the line L perpendicular to the plane α passing through the points $A(a_1, a_2, a_3)$ and $X(x, y, z)$.
 - a) From two points $A(a_1, a_2, a_3)$ and $X(x, y, z)$, find the direction vector \vec{AX} of plane α .
 - b) Find the scalar product of the vector \vec{u} and the vector \vec{AX} obtained in 1 and equate the result to zero since the two vectors are perpendicular. Expand the obtained equation. What can you say about the expanded equation?
2. In each of the following pair of line and plane, after verifying if they are parallel or not, determine whether the given line lies in the plane or they are strictly parallel or the line pierces the plane.
 - a) $\vec{r} = 4\vec{i} + \vec{j} + 2\vec{k} + \lambda(3\vec{i} + \vec{j} + 2\vec{k})$ and $\vec{r} \cdot (\vec{i} + \vec{j} + \vec{k}) = 4$ [$\vec{r} = (x, y, z)$]
 - b) $x - 1 = 2 - y = \frac{3 - z}{4}$ and $\vec{r} \cdot (2\vec{i} - 2\vec{j} + \vec{k}) = 1$ [$\vec{r} = (x, y, z)$]

A line L is perpendicular to plane α if and only if each direction vector of L is perpendicular to each direction vector of α or the scalar product of direction vector of the line and the direction vector of the plane is zero.

In this case, the direction vector of the line is perpendicular to the plane and is said to be the **normal** or **orthogonal** vector of the plane.

Note that the normal vector of the plane can be found from the vector product of its two direction vectors.

From Activity 8.15, the Cartesian equation of plane passing through the point (a_1, a_2, a_3) with orthogonal vector (a, b, c) is $a(x - a_1) + b(y - a_2) + c(z - a_3) = 0$.

A line and a plane are parallel if the direction vector of the line is perpendicular to the normal vector of the plane. There are two possibilities: they are strictly parallel or the line lies in the plane. To see this, do the following: Find any point of the line and check if this point lies on the plane. If this point lies on the plane, then the line is in the plane otherwise the plane and the line are strictly parallel.

Example 8.29

Find the Cartesian equation of plane α passing through the point $(2, -3, 4)$ and perpendicular to the line defined by the points $A(1, 5, 7)$ and $B(-2, 2, 3)$.

Solution

The direction vector of the line is $\overline{AB} = (-3, -3, -4)$.

This is the normal vector of the plane α

$$\text{Thus, } \alpha \equiv -3(x-2) - 3(y+3) - 4(z-4) = 0$$

$$\text{Or } \alpha \equiv 3x + 3y + 4z - 13 = 0.$$

Example 8.30

Find the equation of plane β passing through the point $P(6, -1, 9)$ and perpendicular to the line $\begin{cases} 4x - 3y + 5z = 13 \\ 6x + 7y - 4z = 23 \end{cases}$

Solution

The direction vector of the line is

$$\left(\begin{vmatrix} -3 & 5 \\ 7 & -4 \end{vmatrix}, - \begin{vmatrix} 4 & 5 \\ 6 & -4 \end{vmatrix}, \begin{vmatrix} 4 & -3 \\ 6 & 7 \end{vmatrix} \right) = (12 - 35, 16 + 30, 28 + 18) = (-23, 46, 46)$$

This vector can be written as $(-23, 46, 46) = -23(1, -2, -2)$. Thus, we can take the direction vector to be $(1, -2, -2)$.

Remember that to find the direction vector of the line we can equate the right hand sides to zero, i.e. $\begin{cases} 4x - 3y + 5z = 0 \\ 6x + 7y - 4z = 0 \end{cases}$

Next, replace any variable in the equation by any non zero chosen value and find values of other remaining variables.

Here, let $x = 1$, we have

$$\begin{cases} 4 - 3y + 5z = 0 \\ 6 + 7y - 4z = 0 \end{cases} \Leftrightarrow \begin{cases} -3y + 5z = -4 \\ 7y - 4z = -6 \end{cases} \Leftrightarrow \begin{cases} -12y + 20z = -16 \\ \underline{35y - 20z = -30} \\ 23y = -46 \Rightarrow y = -2, z = -2 \end{cases}$$

Then the equation of plane is

$$\beta \equiv (x-6) - 2(y+1) - 2(z-9) = 0$$

Or

$$\beta \equiv x - 2y - 2z + 10 = 0$$

Example 8.31

Find the equation of plane passing through the point $A(2, 3, -6)$ with vectors $\vec{u} = (-1, 5, 3)$ and $\vec{v} = (4, -4, 1)$ as direction vectors.

Solution

The normal vector \vec{n} of this plane is given by the vector product of its two direction vectors.

$$\vec{n} = \vec{u} \times \vec{v} = \left(\begin{vmatrix} 5 & 3 \\ -4 & 1 \end{vmatrix}, - \begin{vmatrix} -1 & 3 \\ 4 & 1 \end{vmatrix}, \begin{vmatrix} -1 & 5 \\ 4 & -4 \end{vmatrix} \right) = (17, 13, -16)$$

The equation of plane is

$$17(x-2) + 13(y-3) - 16(z+6) = 0 \text{ or } 17x + 13y - 16z = 169$$

Example 8.32

Show that the plane $2x - y - 3z = 4$ is parallel to the line

$$\begin{cases} x = -2 + 2t \\ y = -1 + 4t \\ z = 4 \end{cases}$$

Solution

First, we check if the normal vector of the plane and the direction vector of the line are perpendicular.

$\vec{n} = (2, -1, -3)$ is normal to the plane. $\vec{u} = (2, 4, 0)$ is the direction vector of the line.

$\vec{n} \cdot \vec{u} = 4 - 4 + 0 = 0$. Then, the given line and plane are parallel.

One point of the line is $(-2, -1, 4)$ for $t = 0$. We must check whether this point lies or does not lie on the plane. That is, $2(-2) - 1(-1) - 3(4) = 4 \Rightarrow -15 \neq 4$.

Then, this point does not lie on the plane.

Hence, the line and the plane are parallel and distinct.

Example 8.33

Consider the plane $2x + y - 4z = 4$ and the line

$$\begin{cases} x = t \\ y = 2 + 3t \\ z = t \end{cases}$$

Find all points of intersection.

Solution

The direction vector of the line is $(1, 3, 1)$ and the normal vector of the plane is $(2, 1, -4)$.

We see that $(1, 3, 1) \cdot (2, 1, -4) = 2 + 3 - 4 = 1 \neq 0$. Then the line intersects the plane. So there is a point of intersection.

To find this point of intersection, we substitute the expression for x , y and z from the equations of the line into the equation of the plane and solve for the parameter. That is $2t + (2 + 3t) - 4t = 4 \Leftrightarrow t = 2$.

Now, using $t = 2$ into equations of the line we find the point of intersection. The point of intersection is $(2, 8, 2)$.

Example 8.34

Consider the plane $2x + y - 4z = 4$ and the line

$$\begin{cases} x = 1 + t \\ y = 4 + 2t \\ z = t \end{cases}$$

Find all points of intersection.

Solution

The direction vector of the line is $(1, 2, 1)$ and the normal vector of the plane is $(2, 1, -4)$.

We see that $(1, 2, 1) \cdot (2, 1, -4) = 2 + 2 - 4 = 0$.

Then the line is parallel to the plane. So the line may be contained in the plane or strictly parallel to the plane.

The substitution gives: $2(1+t) + (4+2t) - 4t = 4 \Leftrightarrow 0t + 6 = 4$

No value of t satisfying the given equation. Meaning that the line is strictly parallel to the plane. Then there are no points of intersection.

Example 8.35

Consider the plane $2x + y - 4z = 4$ and the line

$$\begin{cases} x = t \\ y = 4 + 2t \\ z = t \end{cases}$$

Find all points of intersection.

Solution

The direction vector of the line is $(1, 2, 1)$ and the normal vector of the plane is $(2, 1, -4)$.

We see that $(1, 2, 1) \cdot (2, 1, -4) = 2 + 2 - 4 = 0$. Then the line is parallel to the plane. So, the line may be contained in the plane or strictly parallel to the plane.

The substitution gives $2t + (4 + 2t) - 4t = 4 \Leftrightarrow 0t = 0$.

All values of t satisfy the given equation. Then the line is contained in the plane. i.e all points of the line are in its intersection with the plane.

Application Activity 8.15

1. Find equation of plane through point $P(0, 2, -1)$ normal to $\vec{n} = 3\vec{i} - 2\vec{j} - \vec{k}$.
2. Find equation of plane through point $P(2, 4, 5)$ perpendicular to the line $x = 5 + t, y = 1 + 3t, z = 4t$.
3. Determine whether the line $x = 3 + 8t, y = 4 + 5t, z = -3 - t$ is parallel to the plane $x - 3y + 5z = 12$.
4. Find parametric equations of the line through $(5, 0, -2)$ that is parallel to the planes $x - 4y + 2z = 0$ and $2x + 3y - z + 1 = 0$.

5. Find the intersection between the line $\frac{x+1}{2} = \frac{y}{1} = \frac{z}{-1}$ and the plane $x - 2y + 3z + 1 = 0$.
6. Find the intersection between the line $\frac{x-1}{5} = \frac{y}{1} = \frac{z+2}{1}$ and the plane $-x + 3y + 2z + 5 = 0$
7. Find the intersection between the line $x = 1 - t, y = 3t, z = 1 + t$ and the plane $2x - y + 3z = 6$.
8. Find the intersection between the line $x = 1 + 2t, y = 1 + 5t, z = 3t$ and the plane $x + y + z = 2$.
9. Find the intersection between the line $x = 0, y = t, z = t$ and the plane $6x + 4y - 4z = 0$.

8.3.4. Angles of lines and planes

Activity 8.16



1. Find the acute angle between the normal vector of the plane $8x + 5y + 9z = 10$ and the direction vector of the line

$$\begin{cases} x = 2 - 2t \\ y = 1 + 4t \\ z = 1 + t \end{cases}$$
2. Find the acute angle between the normal vectors of the plane $x + 2y - 6z = 10$ and the plane $2x - 3y + 4z = -15$.

a) Angle between a line and a plane

Again, the neatest method is to use a normal vector to the plane. We show how this works in the drawing below.

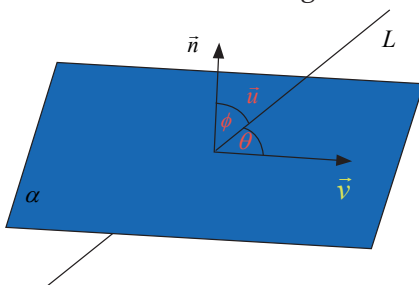

Let ϕ , be the angle between the normal vector \vec{n} and the direction vector \vec{u} , and let θ be the angle between the line and the plane. The plane containing line L and vector \vec{n} is perpendicular to plane α .

Since ϕ and θ are complementary, that is, they add up to 90° , $\phi = 90^\circ - \theta$.

Angle θ can then be found from the scalar product of \vec{n} and \vec{u} .

We have:

$$\cos \phi = \cos(90^\circ - \theta) = \sin \theta$$

$$\text{So, } \vec{n} \cdot \vec{u} = \|\vec{n}\| \|\vec{u}\| \sin \theta \text{ and then, } \theta = \arcsin \left(\frac{\left| \begin{array}{c} \vec{n} \cdot \vec{u} \\ \|\vec{n}\| \cdot \|\vec{u}\| \end{array} \right|}{\|\vec{n}\| \cdot \|\vec{u}\|} \right)$$

Example 8.36

Find the angle between the plane $x + y + z = 4$ and the line

$$\begin{cases} x = 1 + r \\ y = 1 + 2r \\ z = 1 + 3r \end{cases}$$

Solution

$\vec{n} = (1, 1, 1)$ is normal to the plane and $\vec{u} = (1, 2, 3)$ is the direction vector of the line.

Let θ be the angle between that plane and that line. Then,

$$\sin \theta = \frac{\vec{n} \cdot \vec{u}}{\|\vec{n}\| \cdot \|\vec{u}\|} = \frac{6}{\sqrt{42}}$$

$$\theta = \arcsin \left(\frac{6}{\sqrt{42}} \right) = 67.8$$

$$\text{Or } \cos \phi = \frac{6}{\sqrt{42}} \Rightarrow \phi = \arccos \left(\frac{6}{\sqrt{42}} \right) = 22.2 \text{ and}$$

$$\theta = 90 - 22.2 = 67.8$$

Thus, the angle between the given plane and the given line is 67.8 degrees.

b) Angle between two planes

It is important to choose the correct angle here. It is defined as the angle between two lines, one in each plane, so that they are at right angles to the line of intersection of the two planes (like the angle between the tops of the pages of an open book).

The picture below shows part of two planes and the angle between them.

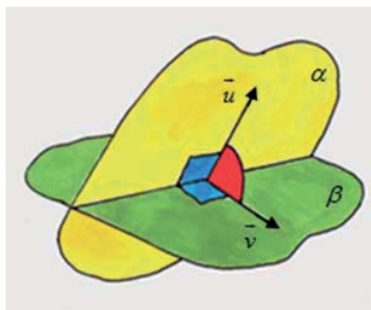

To find this angle, we just need to know a normal vector to each of the planes. Then we can find the angle we want very neatly as we show in the drawing below.

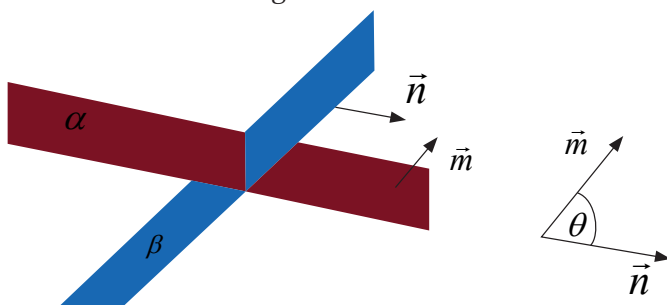

The angle between the planes is the same as the acute angle between their two normal vectors (sliding their tails together if necessary).

Now, we just use $\vec{n} \cdot \vec{m} = \|\vec{n}\| \|\vec{m}\| \cos \theta$ and find the angle in the same way as we did for the two lines. That is $\theta = \arccos \left(\frac{\vec{n} \cdot \vec{m}}{\|\vec{n}\| \|\vec{m}\|} \right)$

Example 8.37

Find the angle between the planes $x + y + z = 4$ and $x + 2y + 3z = 5$.

Solution

$\vec{n} = (1, 1, 1)$ is normal to the first plane and $\vec{m} = (1, 2, 3)$ is normal to the second plane.

$$\cos \theta = \frac{\vec{n} \cdot \vec{m}}{\|\vec{n}\| \cdot \|\vec{m}\|} = \frac{6}{\sqrt{3} \cdot \sqrt{14}} = \frac{6}{\sqrt{42}} \Rightarrow \theta = \arccos\left(\frac{6}{\sqrt{42}}\right) = 22.2$$

Thus, the angle between two planes is 22.2 degrees.

Application Activity 8.16

- Find the angle between the planes: $x + y = 1$, $2x + y - 2z = 2$
- Find the angle between the planes:
 $2x + 2y + 2z = 3$, $2x - 2y - z = 5$ to the nearest hundredth of a radian
- Find the angle between the planes:
 $2x + 2y - z = 3$, $x + 2y + z = 2$ to the nearest hundredth of a radian
- Find the angle between the planes: $x = 0$, $2x - y + z - 4 = 0$ to the nearest degree
- Find the angle between the planes:
 $x + 2y - 2z = 5$, $6x - 3y + 2z = 8$ to the nearest degree
- Determine the angle between the line $\frac{x-1}{2} = \frac{y+1}{1} = \frac{z}{2}$ and the plane $x + y - 1 = 0$.
- Determine the angle between the line $\begin{cases} x + 3y - z + 3 = 0 \\ 2x - y - z - 1 = 0 \end{cases}$ and the plane $2x - y + 3z + 1 = 0$.
- Determine the angle between the line $\begin{cases} y = 2 \\ 3x - z\sqrt{3} = 0 \end{cases}$ and the plane $x = 1$.

8.3.5. Shortest distance from a point to a plane

Activity 8.17



Consider plane $\alpha \equiv ax + by + cz = d$ passing through point $A(a_1, a_2, a_3)$. Consider another point $B(b_1, b_2, b_3)$ which does not lie on plane α . Let \vec{e} be the normalized normal vector of plane α . The shortest distance from point B to plane α can be written as $\|\vec{e}\| \|\overline{AB}\| = \|\vec{e} \cdot \overline{AB}\|$. Develop the expression $\|\vec{e} \cdot \overline{AB}\|$ to find the expression for $\|\overline{AB}\|$.

The distance from point B to plane α is the shortest distance given by the length of perpendicular from that point to the plane.

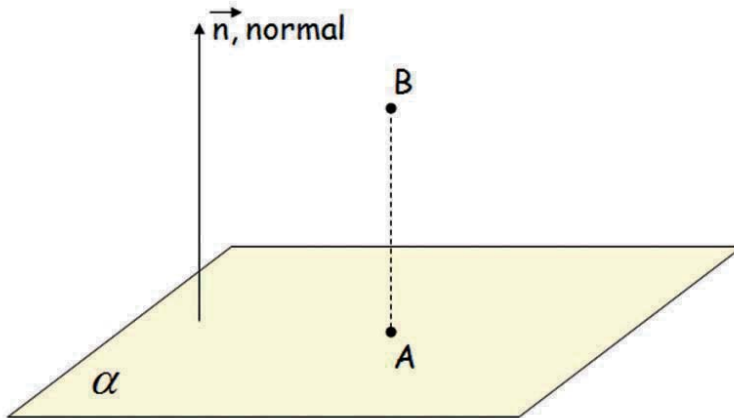

$$d(B, \alpha) = d(A, B) = \|\overline{AB}\|$$

From Activity 8.17; the distance from point $B(b_1, b_2, b_3)$ to plane $\alpha \equiv ax + by + cz = d$ is given by

$$d(B, \alpha) = \frac{|ab_1 + bb_2 + cb_3 - d|}{\sqrt{a^2 + b^2 + c^2}}$$

From this result, we deduce the normal equation of a plane:

$lx + my + nz + t = 0$ is the equation of the plane.

The vector (l, m, n) is normal to the plane. If $l \cdot l + m \cdot m + n \cdot n = 1$ that normal vector is a unit vector. In that case, we say that $lx + my + nz + t = 0$ is a normal equation of the plane.

Example 8.38

$0.5x - 0.5y + \frac{\sqrt{2}}{2}z + 5 = 0$ is the normal equation of the plane

Transform an equation of a plane to a normal equation

If $\alpha = ax + by + cz = d$, the normal equation of this plane is

$$\alpha \equiv \frac{ax + by + cz - d}{\pm\sqrt{a^2 + b^2 + c^2}} = 0.$$

General rule for calculating the shortest distance between a point and a plane

To find the distance between a point and plane,

⊙ find the normal equation of the plane, which is

$$\alpha \equiv \frac{ax + by + cz - d}{\pm\sqrt{a^2 + b^2 + c^2}} = 0$$

⊙ in the expression $\frac{ax + by + cz - d}{\sqrt{a^2 + b^2 + c^2}}$ replace the variables by the corresponding coordinates of the point.

Example 8.39

Find the distance from the point $P(2, 4, 7)$ to the plane $\alpha \equiv 3x + 5y - 6z = 18$.

Solution

The normal equation of this plane is $\alpha \equiv \frac{3x + 5y - 6z - 18}{\pm\sqrt{9 + 25 + 36}} = 0$

Or

$$\alpha \equiv \frac{3x + 5y - 6z - 18}{\pm\sqrt{70}} = 0$$

Now, in the expression $\frac{3x + 5y - 6z - 18}{\sqrt{70}}$, replacing the variables by the corresponding coordinates of the point, we have

$$d(P, \alpha) = \frac{|3 \times 2 + 5 \times 4 - 6 \times 7 - 18|}{\sqrt{70}}$$

Or

$$d(P, \alpha) = \frac{34}{\sqrt{70}}$$

Remark**a) Shortest distance between two planes**

When calculating the distance between two planes, first check if the planes are parallel. If they are not, they intersect and the distance is zero. If they are parallel, find an arbitrary point in one of the planes and calculate its distance to the other plane.

Note that if two planes coincide (identical) the shortest distance is zero.

Example 8.40

Calculate the distance between the two planes given below:

$$2x - 3y + 3z = 12 \quad \text{and} \quad -6x + 9y - 9z = 27$$

Solution

First, let us check to see if they are parallel.

Their normal vectors are $\vec{n} = (2, -3, 3)$ and $\vec{m} = (-6, 9, -9)$

We see that $\vec{m} = -3\vec{n}$, then, the two planes are parallel.

Now, pick a point in the second plane and calculate the distance to the first plane.

Let $x = y = 0$. Then $z = -3$. A point in the second plane is $P(0, 0, -3)$.

Use the distance formula to calculate the distance from point P to the first plane. The first plane is:

$$2x - 3y + 3z = 12$$

$$\Leftrightarrow 2x - 3y + 3z - 12 = 0$$

$$\text{Distance is } \frac{|2 \times 0 - 3 \times 0 - 3 \times (-3) - 12|}{\sqrt{2^2 + (-3)^2 + 3^2}} = \frac{21}{\sqrt{22}}$$

b) Shortest distance between a line and a plane

When calculating the distance between a line and a plane, first check if the line is parallel to the plane. If not, they intersect and the distance is zero. If they are parallel, find a point on the line and calculate its distance to the plane.

Example 8.41

Find the shortest distance between the plane $2x - y - 3z = 4$ and the line

$$\begin{cases} x = -2 + 2t \\ y = -1 + 4t \\ z = 4 \end{cases}$$

Solution

First, we check if the line is parallel to the plane. We need to know that the normal vector of the plane and the direction vector of the line are perpendicular.

$\vec{n} = (2, -1, -3)$ is normal to the plane. $\vec{u} = (2, 4, 0)$ is the direction vector of the line.

$\vec{n} \cdot \vec{u} = 4 - 4 + 0 = 0$. Then, the given line and the given plane are parallel.

One point of the line is $(-2, -1, 4)$ for $t = 0$.

The distance from this point to the plane is

$$d = \frac{|2(-2) - (-1) - 3(4) - 4|}{\sqrt{4 + 1 + 9}} = \frac{|-4 + 1 - 12 - 4|}{\sqrt{14}} = \frac{19}{\sqrt{14}} \text{ units}$$

Application Activity 8.17

1. Find the distance from the point $(2, -3, 4)$ to the plane $x + 2y + 2z = 13$.
2. Find the distance from the point $(0, 1, 1)$ to the plane $4y + 3z = -12$.
3. Find the distance from the point $(0, -1, 0)$ to the plane $2x + y + 2z = 4$.
4. Find the shortest distance between the planes $x + 2y + 6z = 1$ and $x + 2y + 6z = 10$.
5. Find the shortest distance between the planes $-2x + y + z = 0$ and $6x - 3y - 3z - 5 = 0$.

8.3.6. Projection of a line onto the plane

Activity 8.18



Find the equation of plane containing the line $L \equiv \begin{cases} x = 2 + t \\ y = 3 - 2t \\ z = 1 + t \end{cases}$ and perpendicular to the plane $\alpha \equiv 2x + 3y - 2z = 12$.

To find the projection of the line AB on the plane α , we need a plane β containing the given line AB and perpendicular to the given plane α . The equation of the plane β and the plane α taken together are the equations of the projection.

Note that any point of the line AB is also a point of the plane β and the direction vector of the line AB and the normal vector of plane β are perpendicular (their scalar product is zero). Also remember that the two planes are perpendicular if their normal vectors are perpendicular.

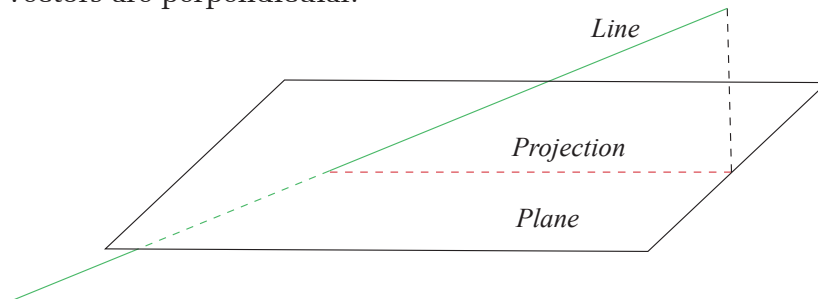

Example 8.42

Find the equation of the projection of the line $\frac{x-1}{2} = \frac{y+1}{-1} = \frac{z-3}{4}$ on the plane $x + 2y + z = 12$.

Solution

Let AB be the given line. Pass a plane $ABCD$ through AB perpendicular to the given plane intersecting the latter in the line CD . Then CD is the projection of AB on the given plane.

A point on the given line is $P(1, -1, 3)$.

The direction vector of the line is $\vec{u} = (2, -1, 4)$

The normal vector of the given plane is $\vec{n} = (1, 2, 1)$

Any plane through AB is $a(x-1) + b(y+1) + c(z-3) = 0$ (1) where $2a - b + 4c = 0$ (2).

It will be perpendicular to $x + 2y + z = 12$ (3) if $a + 2b + c = 0$ (4).

Solving (2) and (4), we have

$$\begin{cases} a = -9 \\ b = 2 \\ c = 5 \end{cases}$$

Finally, we have plane through AB is

$$-9(x-1) + 2(y+1) + 5(z-3) = 0 \text{ or}$$

$$9x - 2y - 5z + 4 = 0 \quad (5)$$

Equations (3) and (5) taken together are the equations of the projection CD.

Application Activity 8.18

- Determine the projection of the line $\frac{x-15}{15} = \frac{y+12}{-15} = \frac{z-17}{11}$ onto the plane $13x - 9y + 16z - 69 = 0$
- Determine the projection of the line $\frac{x-1}{2} = \frac{y+1}{-2} = \frac{z-7}{-1}$ onto the plane $2x - 3y + z - 30 = 0$.

8.3.7. Finding image of a point onto the plane

Activity 8.19



Find the symmetric equations of the line passing through point $A(1, 2, 1)$ and perpendicular to the plane $\alpha \equiv x - 4y - 2z = 12$ and hence the intersection between the obtained line and the plane α .

When finding the image of a point P under the reflection in plane α , we need to find the line, say L , through point P and perpendicular to the plane α .

The next is to find the intersection of line L and plane α , say N . Now, if Q is the image of P , the point N is the midpoint of PQ . From this, we can find the coordinate of Q .

Similarly, if we need the image of a line, we will need the parametric form of any point on the line and then find its image using the same method. The image will be in parametric form.

Now, replacing the parameter by any two chosen values in the obtained image, we will get two points. From these two points, we can find the equations of the line which will be the image of the given line.

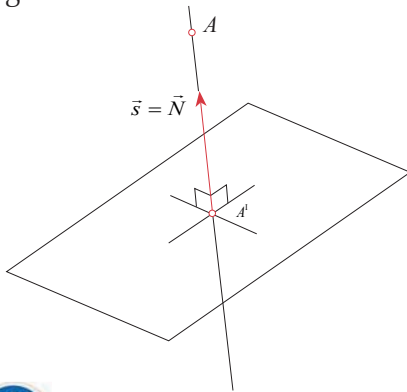

Notice

To find a projection of a point onto a line, we find the plane perpendicular to the line passing through the given point (direction vector of the line is the normal vector of the plane). Next, the projection of the given point is the intersection between the obtained plane and the given line.

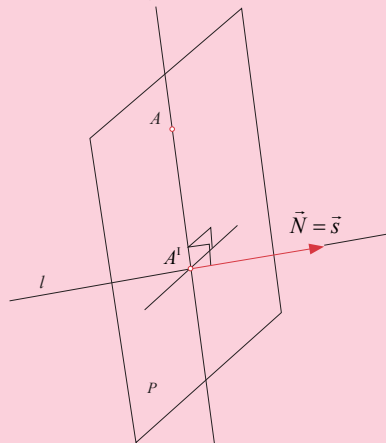

Example 8.43

Find the image of the point $P(2, -3, 4)$ under the reflection the plane $4x + 2y - 4z + 3 = 0$

Solution

The normal vector of the plane is $\vec{n} = (4, 2, -4)$. This vector is the direction vector of the line perpendicular to the plane.

The line through $P(2, -3, 4)$ and perpendicular to the given plane is given by

$$\begin{cases} x = 2 + 4r \\ y = -3 + 2r \\ z = 4 - 4r \end{cases}$$

Putting these values in the equation of the plane and solving for r , we have

$$8 + 16r - 6 + 4r - 16 + 16r + 3 = 0 \quad \text{or}$$

$$r = \frac{11}{36}$$

Back to the parametric equations of the line, we have

$$\begin{cases} x = 2 + 4 \times \frac{11}{36} = \frac{58}{18} \\ y = -3 + 2 \times \frac{11}{36} = -\frac{43}{18} \\ z = 4 - 4 \times \frac{11}{36} = \frac{50}{18} \end{cases}$$

Then the intersection of the given plane and its perpendicular line passing through the given point is $\left(\frac{58}{18}, -\frac{43}{18}, \frac{50}{18}\right)$.

Let the image of $P(2, -3, 4)$ be point $Q(a, b, c)$.

The point $\left(\frac{58}{18}, -\frac{43}{18}, \frac{50}{18}\right)$ is the midpoint of PQ .

Or

$$\left(\frac{2+a}{2}, \frac{-3+b}{2}, \frac{4+c}{2}\right) = \left(\frac{58}{18}, -\frac{43}{18}, \frac{50}{18}\right)$$

Or

$$\begin{cases} \frac{2+a}{2} = \frac{58}{18} \\ \frac{-3+b}{2} = -\frac{43}{18} \\ \frac{4+c}{2} = \frac{50}{18} \end{cases} \Leftrightarrow \begin{cases} 2+a = \frac{58}{9} \\ -3+b = -\frac{43}{9} \\ 4+c = \frac{50}{9} \end{cases} \Rightarrow \begin{cases} a = \frac{40}{9} \\ b = -\frac{16}{9} \\ c = \frac{14}{9} \end{cases}$$

Thus, the image of $P(2, -3, 4)$ with respect to the plane $4x + 2y - 4z + 3 = 0$ is $Q\left(\frac{40}{9}, -\frac{16}{9}, \frac{14}{9}\right)$.

Application Activity 8.19

1. Find the orthogonal projection of the point $(5, -6, 3)$ onto the plane $3x - 2y + z - 2 = 0$.
2. Find the orthogonal projection of the point $(4, -2, 1)$ onto the line $\frac{x+1}{-3} = \frac{y-3}{5} = \frac{z-2}{3}$.

8.3.8. Position of planes

Position of two planes

$$\alpha \equiv a_1x + b_1y + c_1z = d_1$$

$$\beta \equiv a_2x + b_2y + c_2z = d_2$$

We need $S = \alpha \cap \beta$, that is

$$S = \{(x, y, z) \in \mathbb{R}^3 : a_1x + b_1y + c_1z = d_1 \text{ and } a_2x + b_2y + c_2z = d_2\}.$$

Two cases occur:

Case 1. Normal vectors are proportional:

$$(a_1, b_1, c_1) = k(a_2, b_2, c_2), \quad k \in \mathbb{R}_0 \Rightarrow \alpha \parallel \beta$$

$$\text{If } (a_1, b_1, c_1, d_1) = k(a_2, b_2, c_2, d_2), \quad k \in \mathbb{R}_0$$

The two planes coincide. That is, $\alpha = k\beta, k \in \mathbb{R}_0$. So $S = \alpha$ or $S = \beta$

$$\text{If } (a_1, b_1, c_1, d_1) \neq k(a_2, b_2, c_2, d_2), \quad k \in \mathbb{R}_0$$

The two planes are parallel and distinct and hence no intersection.

Thus, $S = \emptyset$.

Case 2. Normal vectors are not proportional:

$$(a_1, b_1, c_1) \neq k(a_2, b_2, c_2), \quad k \in \mathbb{R}_0 \Rightarrow \alpha \not\parallel \beta$$

The two planes intersect and their intersection is a line defined by the equations of the two planes taking together.

$$\begin{cases} a_1x + b_1y + c_1z = d_1 \\ a_2x + b_2y + c_2z = d_2 \end{cases}$$

General equation of a line**Activity 8.20**

1. Find vector \vec{u} parallel to the line of the intersection of the planes $x + y - z = 0$ and $y + 2z = 6$.
2. Take any point common to the two planes given in 1).
3. Find parametric equations of line whose direction vector is a vector parallel to $x + y - z = 0$ and $y + 2z = 6$ and passes through the point found in 2).

The general equation of a straight line in space is

$$\begin{cases} a_1x + b_1y + c_1z = d_1 \\ a_2x + b_2y + c_2z = d_2 \end{cases}$$

The direction vector of this line is

$$\left(\begin{vmatrix} b_1 & c_1 \\ b_2 & c_2 \end{vmatrix}, -\begin{vmatrix} a_1 & c_1 \\ a_2 & c_2 \end{vmatrix}, \begin{vmatrix} a_1 & b_1 \\ a_2 & b_2 \end{vmatrix} \right)$$

Or to find the direction vector of the line, we can equate the right hand sides of the general equations to zero.

i.e,

$$\begin{cases} a_1x + b_1y + c_1z = 0 \\ a_2x + b_2y + c_2z = 0 \end{cases}$$

Next, replace any variable in the equation by any chosen value and find values of other remaining variables.

Example 8.44

Find the intersection of $\alpha \equiv 2x + y - 3z = 2$ and $\beta \equiv 4x + 2y - 6z = 21$

Solution

The normal vectors are $\vec{u} = (2, 1, -3)$ and $\vec{v} = (4, 2, -6)$.

Since $\vec{v} = 2\vec{u}$, the two planes are parallel. We need to know if they are distinct or not.

$(2, 1, -3, 2)$ and $(4, 2, -6, 21)$ are not proportional, thus, the two planes are parallel and distinct and hence no intersection between them.

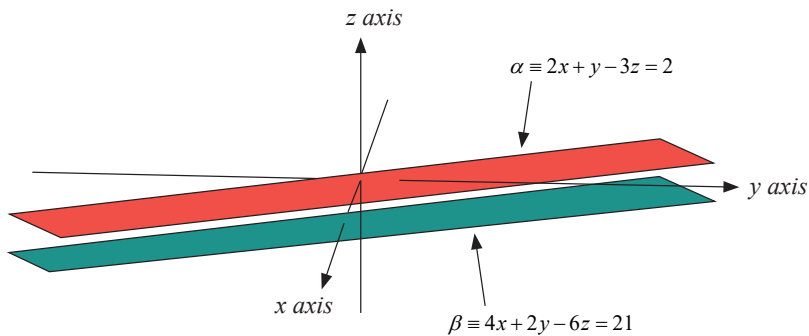
**Example 8.45**

Find the intersection of $\alpha \equiv 6x - 10y + 14z = 38$ and $\beta \equiv 3x - 5y + 7z = 19$

Solution

We see that $\alpha = 2(3x - 5y + 7z = 19) = 2\beta$

So, the two planes coincide and the intersection is any one of them.

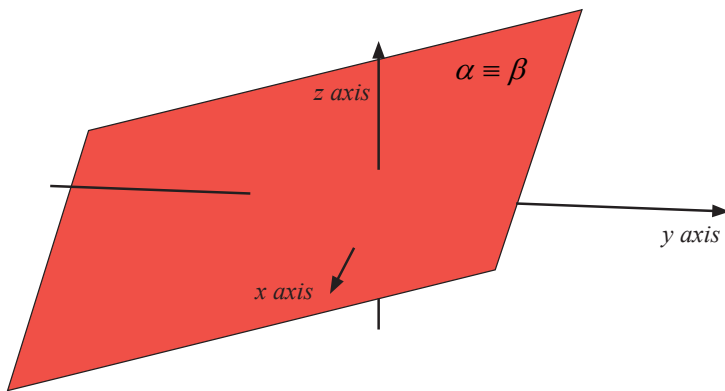

Example 8.46

Find intersection of $\alpha \equiv 4x - 3y + 7z = -3$ and $\beta \equiv 5x + 2y - 6z = 25$

Solution

The normal vectors are $\vec{n}_1 = (4, -3, 7)$ and $\vec{n}_2 = (5, 2, -6)$

\vec{n}_1 and \vec{n}_2 are not proportional, thus, the two plane intersect.

Solving the simultaneous equations, $4x - 3y + 7z = 0$ and $5x + 2y - 6z = 0$, you get one of the direction vectors of intersection line.

$$\left(\begin{vmatrix} -3 & 7 \\ 2 & -6 \end{vmatrix}, - \begin{vmatrix} 4 & 7 \\ 5 & -6 \end{vmatrix}, \begin{vmatrix} 4 & -3 \\ 5 & 2 \end{vmatrix} \right) = (18 - 14, 24 + 35, 8 + 15) \\ = (4, 59, 23)$$

The two planes are secant. So there is a line of intersection.

The direction vector of the line is $(4, 59, 23)$ obtained above.

To find a common point of the two planes, let one variable be zero and solve for others.

Let $z = 0$, solving for others gives $x = 3, y = 5$. Thus, the point on the line is $(3, 5, 0)$.

The equations of the line of intersection are

$$\begin{cases} x = 3 + 4r \\ y = 5 + 59r, \text{ where } r \text{ is a parameter.} \\ z = 23r \end{cases}$$

Or the line of intersection can be defined by the equations

$$\begin{cases} 4x - 3y + 7z = -3 \\ 5x + 2y - 6z = 25 \end{cases}$$

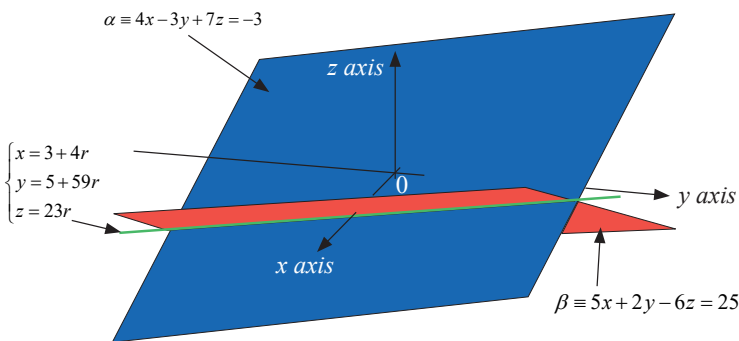

Example 8.47

Given the Cartesian equations of the line

$$L \equiv \begin{cases} 3x - 7y = 4 \\ 5x + 2z = 1 \end{cases}, \text{ find its direction vector.}$$

Solution

The direction vector is

$$\left(\begin{vmatrix} -7 & 0 \\ 0 & 2 \end{vmatrix}, -\begin{vmatrix} 3 & 0 \\ 5 & 2 \end{vmatrix}, \begin{vmatrix} 3 & -7 \\ 5 & 0 \end{vmatrix} \right) = (-14, -6, 35)$$

Note that any other non zero scalar multiple of this vector is also a direction vector for the given line.

Or

To find the direction vector, let $x = 1$ and replace this value in the system

$$\begin{cases} 3x - 7y = 0 \\ 5x + 2z = 0 \end{cases}$$

We obtain the vector $\left(1, \frac{3}{7}, -\frac{5}{2}\right)$. Since any other non zero scalar multiple of this vector is also a direction vector for the given line, we can multiply this vector by -14 to obtain $(-14, -6, 35)$.

Example 8.48

Find the equation of the intersection line of planes $3x - 6y - 2z = 15$ and $2x + y - 2z = 5$ in standard form

Solution

Direction vector of intersection line is

$$\begin{vmatrix} \vec{i} & \vec{j} & \vec{k} \\ 3 & -6 & -2 \\ 2 & 1 & -2 \end{vmatrix} = \vec{i} \begin{vmatrix} -6 & -2 \\ 1 & -2 \end{vmatrix} - \vec{j} \begin{vmatrix} 3 & -2 \\ 2 & -2 \end{vmatrix} + \vec{k} \begin{vmatrix} 3 & -6 \\ 2 & 1 \end{vmatrix} = 14\vec{i} + 2\vec{j} + 15\vec{k}$$

Any non zero scalar multiple of this vector will do as well.

We find a common point by assigning a value to one variable and calculating the other two from the given equations. For instance, letting $z = 0$ in the two equations and solving for y and x simultaneously yields $(3, -1, 0)$, so is one point on the line.

Thus, the line has standard form equation $\frac{x-3}{14} = \frac{y+1}{2} = \frac{z}{15}$.

Example 8.49

Find the equation of plane γ passing through the point $A(3,5,2)$ and perpendicular to the plane $\beta \equiv -4x - y + z = 4$

Solution

The normal vector of plane β is $\vec{u} = (-4, -1, 1)$. The normal vector of plane γ is perpendicular to \vec{u} .

Take for example, $\vec{v} = (1, -2, 2)$, the equation of plane γ is $\gamma \equiv (x-3) - 2(y-5) + 2(z-2) = 0$

Or

$$\gamma \equiv x - 2y + 2z + 3 = 0$$

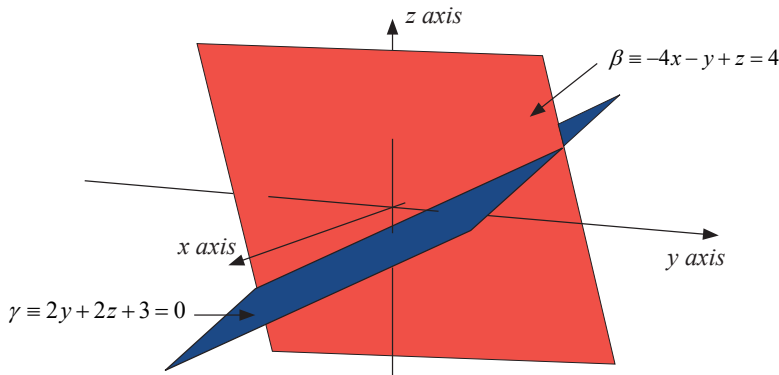

Example 8.50

Find the equation of plane β passing through the point $P(5,8,1)$ and parallel to the plane $\alpha \equiv 3x - 5y - 7z = 12$.

Solution

These two planes have the same normal vector.

Then,

$$\beta \equiv 3(x-5) - 5(y-8) - 7(z-1) = 0$$

Or

$$\beta \equiv 3x - 5y - 7z + 32 = 0$$

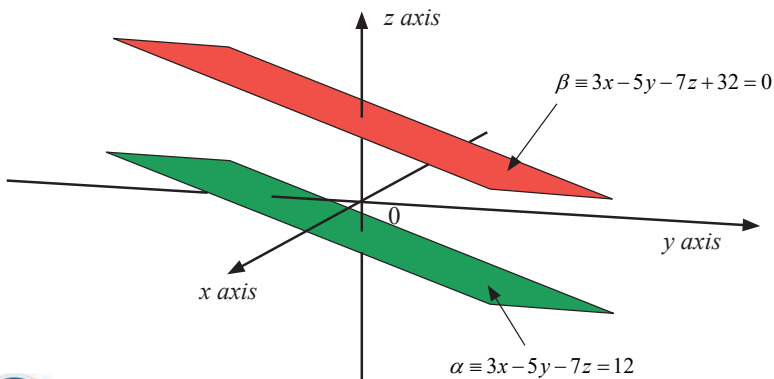

i Notice

Given that plane β passes through points $A(a_1, a_2, a_3)$ and $B(b_1, b_2, b_3)$ and is perpendicular to another plane $\alpha \equiv c_1x + c_2y + c_3z = d$, the mixed product can easily help us to find the equation of plane β .

In fact, the normal vector of plane α , which is $\vec{n} = (c_1, c_2, c_3)$, is the direction vector of the plane β and another direction vector of β is vector \overline{AB} . The normal vector of β is now $\vec{m} = \vec{n} \times \overline{AB}$ and the equation of β is $\vec{m} \cdot \overline{AX}$ where $X(x, y, z)$ represents any point on plane β .

We can write $\beta \equiv \vec{m} \cdot \overline{AX}$

This can be written in determinant form as follows:

$$\beta \equiv \begin{vmatrix} x-a_1 & y-a_2 & z-a_3 \\ b_1-a_1 & b_2-a_2 & b_3-a_3 \\ c_1 & c_2 & c_3 \end{vmatrix} = 0$$

Example 8.51

Find the equation of plane passing through the points $A(3, 2, -1)$ and $B(0, 5, -3)$ and perpendicular to the plane $3x - 4y + 6z = 13$.

Solution

The required equation is given by

$$\begin{vmatrix} x-3 & y-2 & z+1 \\ 0-3 & 5-2 & -3+1 \\ 3 & -4 & 6 \end{vmatrix} = 0$$

Or

$$\begin{vmatrix} x-3 & y-2 & z+1 \\ -3 & 3 & -2 \\ 3 & -4 & 6 \end{vmatrix} = 0$$

$$\Leftrightarrow (18-8)(x-3) - (-18+6)(y-2) + (12-9)(z+1) = 0$$

$$\Leftrightarrow 10(x-3) + 12(y-2) + 3(z+1) = 0$$

$$\Leftrightarrow 10x - 30 + 12y - 24 + 3z + 3 = 0$$

Finally, the required equation is

$$10x + 12y + 3z - 51 = 0$$

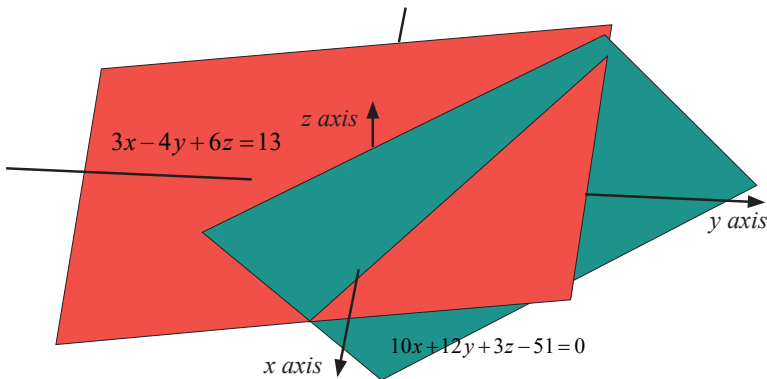

Application Activity 8.20

1. Find in a symmetrical form, the equations of the line

a)
$$\begin{cases} 4x + 4y - 5z = 12 \\ 8x + 12y - 13z = 32 \end{cases}$$

b)
$$\begin{cases} x + y + z + 1 = 0 \\ 4x + y - 2z + 2 = 0 \end{cases}$$

c)
$$\begin{cases} x - 2y + 3z = 4 \\ 2x - 3y + 4z = 5 \end{cases}$$

2. Find the direction vector of the line

a)
$$\begin{cases} x + y + z - 1 = 0 \\ 2x - y - 3z + 1 = 0 \end{cases}$$

b)
$$\begin{cases} x - ay + b = 0 \\ cy - z + d = 0 \end{cases}$$

3. Show that the two planes $x - y = 3$ and $x + y + z = 0$ intersect, and find a vector \vec{u} parallel to their line of intersection.

4. Find an equation of the plane passing through the line of intersection of two planes $x + y - 2z = 6$ and $2x - y + z = 2$.

5. Find equation of plane passing through $(1,1,1)$ and $(2,0,3)$ and perpendicular to the plane $x + 2y - 3z = 0$.
6. Find equation of plane passing through the line $x + y = 2, y - z = 3$ and perpendicular to the plane $2x + 3y + 4z = 5$.
7. Find equation of the plane through the origin that is parallel to the plane $4x - 2y + 7z + 12 = 0$.

Activity 8.21

Consider the planes $\alpha \equiv x + 2y - 3z = 5, \beta \equiv 3x - 4y - 2z = 11$ and $\gamma \equiv 2x + 4y - 6z = 10$

Show that two of them coincide and the third one is secant to them.

Consider three planes

$$\alpha \equiv a_1x + b_1y + c_1z = d_1$$

$$\beta \equiv a_2x + b_2y + c_2z = d_2$$

$$\gamma \equiv a_3x + b_3y + c_3z = d_3$$

We need $S = \alpha \cap \beta \cap \gamma$, that is

$$S = \{(x, y, z) \in \mathbb{R}^3 : a_1x + b_1y + c_1z = d_1, a_2x + b_2y + c_2z = d_2 \text{ and } a_3x + b_3y + c_3z = d_3\}$$

There are three possible cases:

1. These planes are parallel if and only if the left hand sides of three equations are proportional.

That is $(a_1, b_1, c_1) = k(a_2, b_2, c_2)$ and $(a_1, b_1, c_1) = m(a_3, b_3, c_3)$

In this case, the planes may be identical or distinct. We have two cases:

- ⊙ If $(a_1, b_1, c_1, d_1) = k(a_2, b_2, c_2, d_2)$ $(a_1, b_1, c_1, d_1) = m(a_3, b_3, c_3, d_3)$ and $(a_2, b_2, c_2, d_2) = n(a_3, b_3, c_3, d_3)$

The three equations are proportional and hence the three planes are coincident (identical), means that $\alpha \equiv \beta \equiv \gamma$



- ⊙ If $(a_1, b_1, c_1, d_1) \neq k(a_2, b_2, c_2, d_2)$ or $(a_1, b_1, c_1, d_1) \neq m(a_3, b_3, c_3, d_3)$ or $(a_2, b_2, c_2, d_2) \neq n(a_3, b_3, c_3, d_3)$

There are two equations that are not proportional but with proportional left hand sides and hence two planes are parallel and distinct and the third may be coincident to one of the other two or distinct to another. Then there is no intersection.



- Two of them are parallel and the third is secant if and only if only two equations have the left hand sides that are proportional.

In this case, there are two planes that are parallel and the third is secant.

- ⊙ If only two equations are proportional, two planes are coincident and the third is secant to them. Hence the intersection is a straight line.

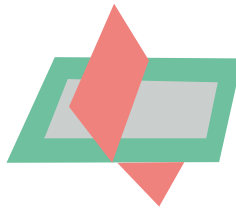

- ⊙ If the left hand sides of only two equations are proportional, two planes are parallel and distinct. Hence no intersection.

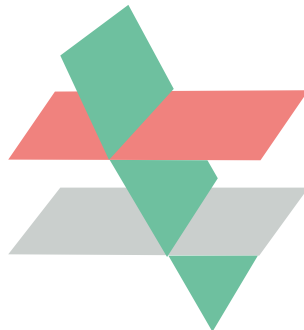

3. No plane is parallel to another if and only if no left hand side of any equation is proportional to another.
- a) There is one left hand side which is a linear combination of two others; in this case, there is a line of intersection of two planes which is parallel to the third.
- i) If the corresponding equation is not a linear combination of two others, the line of intersection of two planes is strictly parallel to the third plane and hence there is no intersection between three planes.



- ii) If the corresponding equation is a linear combination of two others, the line is included in the third plane and hence this line is the intersection for three planes.

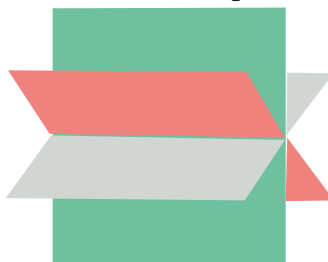

To find equation of the line of intersection, we proceed in the same way as for the case of two planes by taking any two equations from the three given equations of planes.

- b) No left hand side is a linear combination of others, meaning that the three equations are linearly independent; in this case, the line of intersection of two planes pierces the third plane and hence there is a point of intersection between three planes.

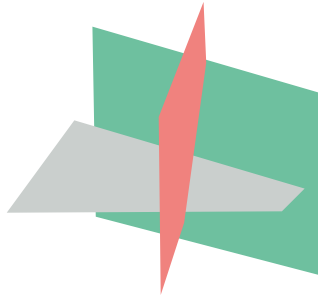

To find this point, we solve simultaneously the system

$$\begin{cases} a_1x + b_1y + c_1z = d_1 \\ a_2x + b_2y + c_2z = d_2 \\ a_3x + b_3y + c_3z = d_3 \end{cases}$$

Example 8.52

Find the intersection of $\alpha \equiv x - 2y + 3z = 6$, $\beta \equiv 2x - 4y + 6z = 12$ and $\gamma \equiv 3x - 6y + 9z = 18$

Solution

All equations are proportional

$$(2x - 4y + 6z = 12) = 2(x - 2y + 3z = 6)$$

$$(3x - 6y + 9z = 18) = 3(x - 2y + 3z = 6)$$

$$(2x - 4y + 6z = 12) = \frac{2}{3}(3x - 6y + 9z = 18)$$

Then the three planes coincide.

Thus, $S = \alpha = \beta = \gamma$.

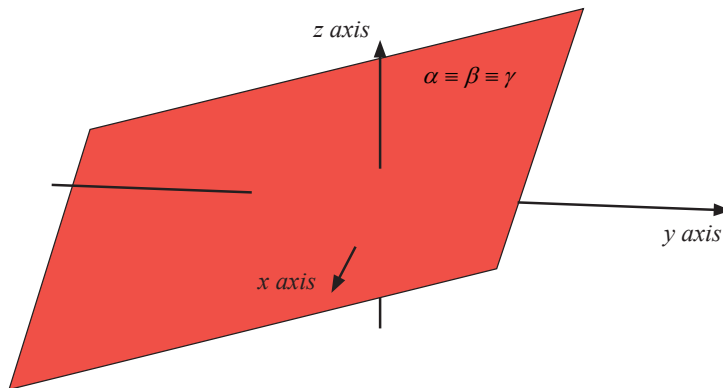

Example 8.53

Find the intersection between $\alpha \equiv 2x + 3y - 5z = -4$,
 $\beta \equiv 6x + 9y - 15z = 50$ and $\gamma \equiv -2x + 2y + 2z = -3$.

Solution

The planes $\alpha \equiv 2x + 3y - 5z = -4$ and $\beta \equiv 6x + 9y - 15z = 50$ are parallel and distinct since the left hand sides of their equations are proportional but not the equations.

The third plane, $\gamma \equiv -2x + 2y + 2z = -3$ is secant to α and β because its left hand side is not proportional to any of the two left hand sides of α and β . Thus, there is no intersection between three planes.

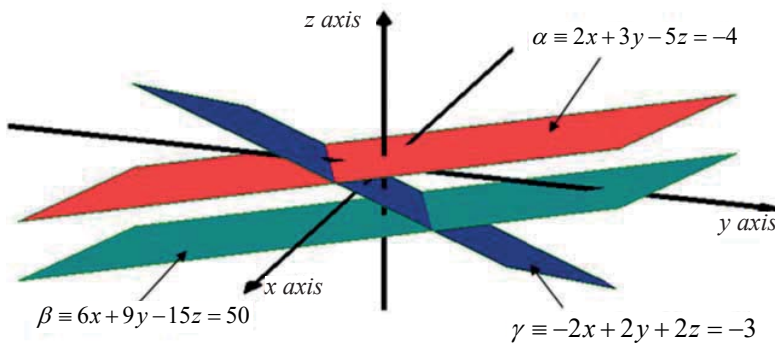
**Example 8.54**

Find the intersection between $\alpha \equiv 2x - 3y + 5z = 12$,
 $\beta \equiv 3x + 5y - 4z = 8$ and $\gamma \equiv 7x - y + 6z = 12$

Solution

We see that the left hand side for γ is a linear combination of the left hand sides for α and β since $7x - y + 6z = 2(2x - 3y + 5z) + (3x + 5y - 4z)$. But the equation for γ is not a linear combination for two others.

That is,

$$7x - y + 6z = 2(2x - 3y + 5z) + (3x + 5y - 4z) \text{ but}$$

$$(7x - y + 6z = 12) \neq 2(2x - 3y + 5z = 12) + (3x + 5y - 4z = 8).$$

Then there is a line of intersection for planes α and β and this line is strictly parallel to the plane γ . Thus, there is no intersection for three planes.

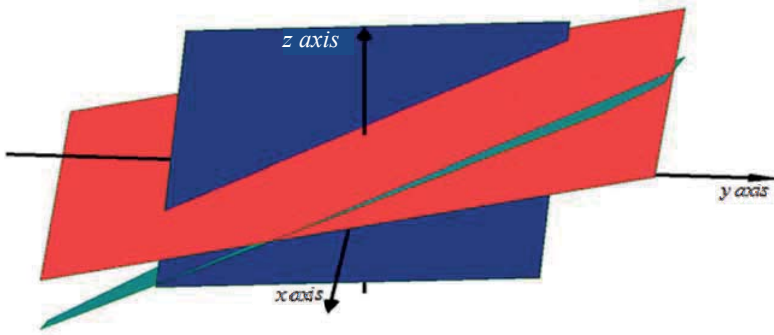

Let us rotate in different direction to see very well if there is no intersection, we have the following

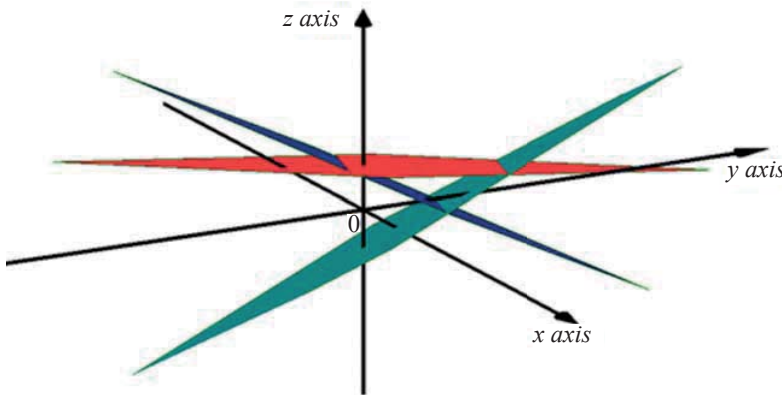

This shows us that there is no intersection for three planes.

Example 8.55

Find the intersection between $\alpha \equiv 3x - 5y - 8z = 12$,
 $\beta \equiv x + y - 3z = 7$ and $\gamma \equiv 10x - 14y - 27z = 43$

Solution

We see that the left hand side for γ is a linear combination of the left hand sides for α and β since $10x - 14y - 27z = 3(3x - 5y - 8z) + (x + y - 3z)$ and the equation for γ is a linear combination of two others.

That is,

$$10x - 14y - 27z = 3(3x - 5y - 8z) + (x + y - 3z) \text{ and}$$

$$(10x - 14y - 27z = 43) = 3(3x - 5y - 8z = 12) + (x + y - 3z = 7).$$

Then there is a line of intersection for three planes. Taking any two equations, say $\alpha \equiv 3x - 5y - 8z = 12$ and $\beta \equiv x + y - 3z = 7$, this line of intersection is defined by

$$\begin{cases} 3x - 5y - 8z = 12 \\ x + y - 3z = 7 \end{cases}$$

Or

Using two planes $\alpha \equiv 3x - 5y - 8z = 12$ and $\beta \equiv x + y - 3z = 7$ the direction vector of the line of intersection is

$$\left(\begin{vmatrix} -5 & -8 \\ 1 & -3 \end{vmatrix}, - \begin{vmatrix} 3 & -8 \\ 1 & -3 \end{vmatrix}, \begin{vmatrix} 3 & -5 \\ 1 & 1 \end{vmatrix} \right) = (23, 1, 8)$$

Let $z = 0$, we have $\begin{cases} 3x - 5y = 12 \\ x + y = 7 \end{cases} \Leftrightarrow \begin{cases} x = \frac{47}{8} \\ y = \frac{9}{8} \end{cases}$

And the point $\left(\frac{47}{8}, \frac{9}{8}, 0 \right)$ is the point on the line of intersection.

Then the line is given by

$$\begin{cases} x = \frac{47}{8} + 23r \\ y = \frac{9}{8} + r \\ z = 8r \end{cases} \quad \text{where } r \text{ is a parameter.}$$

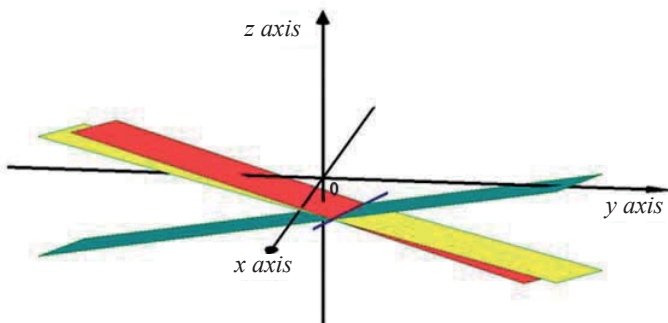

Example 8.56

Find the intersection between $\alpha \equiv 5x - 7y + 8z = -57$,
 $\beta \equiv 4x + 6y - 9z = 78$ and $\gamma \equiv 9x + 8y + 7z = 77$

Solution

We see that the three equations are independent since no equation is a linear combination of others (or no left hand side is linear combination of others). So, the intersection for three planes is a point.

We need to solve the system

$$\begin{cases} 5x - 7y + 8z = -57 \\ 4x + 6y - 9z = 78 \\ 9x + 8y + 7z = 77 \end{cases}$$

Solving this system gives the point $(3, 8, -2)$ which is the point of intersection.

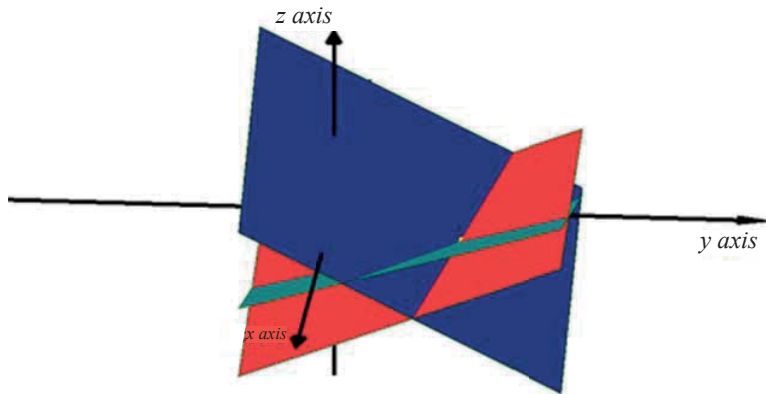
**Application Activity 8.21**

Find the intersection between planes:

- $\alpha \equiv 2x + 6y + 7z = 10$, $\beta \equiv 4x + 12y + 14z = 20$ and $\gamma \equiv 10x + 30y + 35z = 50$
- $\alpha \equiv 3x - 3y + 6z = 24$, $\beta \equiv 7x - 7y + 14z = 56$ and $\gamma \equiv 5x - 5y + 10z = 13$
- $\alpha \equiv x + y + z = 6$, $\beta \equiv 2x + y - z = 1$ and $\gamma \equiv 3x + 2y + z = 10$
- $\alpha \equiv 2x - 3y + 4z - 1 = 0$, $\beta \equiv x - y - z + 1 = 0$ and $\gamma \equiv -x + 2y - z + 2 = 0$
- $\alpha \equiv x + y - z + 3 = 0$, $\beta \equiv -4x + y + 4z - 7 = 0$ and $\gamma \equiv -2x + 3y + 2z - 2 = 0$

8.4. Sphere in 3 dimensions

8.4.1. Equation of a sphere

A **sphere** is the locus of a point in space which remains at a constant distance called the **radius** from a fixed point called the **centre** of the sphere.



Activity 8.22

1. Develop the equation $(x-k)^2 + (y-l)^2 + (z-m)^2 = r^2$.
2. Compare the equation $x^2 + y^2 + z^2 + ax + by + cz + d = 0$ and the one obtained in 1) and find the value of k , l , m and r in function of a , b , c , and d .

The equation of a sphere of centre (k, l, m) and radius r is given by

$$S \equiv (x-k)^2 + (y-l)^2 + (z-m)^2 = r^2$$

From Activity 8.22, the general equation of a sphere is:

$$x^2 + y^2 + z^2 + ax + by + cz + d = 0$$

In this equation:

The centre is

$$\Omega = \left(-\frac{a}{2}, -\frac{b}{2}, -\frac{c}{2} \right)$$

and the radius is given by

$$r = \frac{1}{2} \sqrt{a^2 + b^2 + c^2 - 4d}, \text{ provided that } a^2 + b^2 + c^2 - 4d > 0.$$

From this general equation, as it contains four constants a, b, c and d , if we are given that a sphere passes through four points, each of which gives one independent equation in the constants. We can find the values of four constants a, b, c and d by solving the four simultaneous equations.

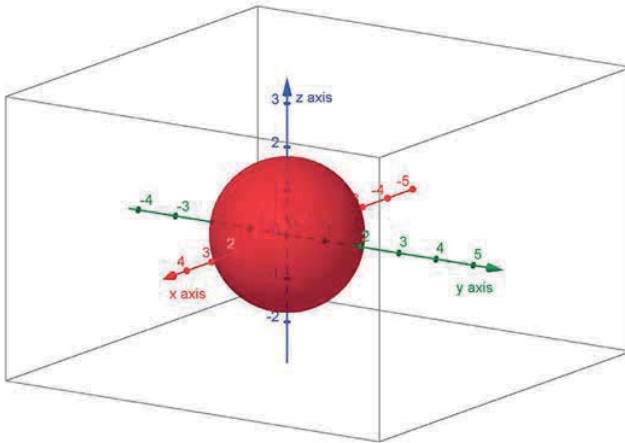

Example 8.57

Find the equation of the sphere whose centre is $(-6, 1, 3)$ and radius 4.

Solution

The required equation is given by: $(x - k)^2 + (y - l)^2 + (z - m)^2 = r^2$

Then it becomes: $(x + 6)^2 + (y - 1)^2 + (z - 3)^2 = 4^2$

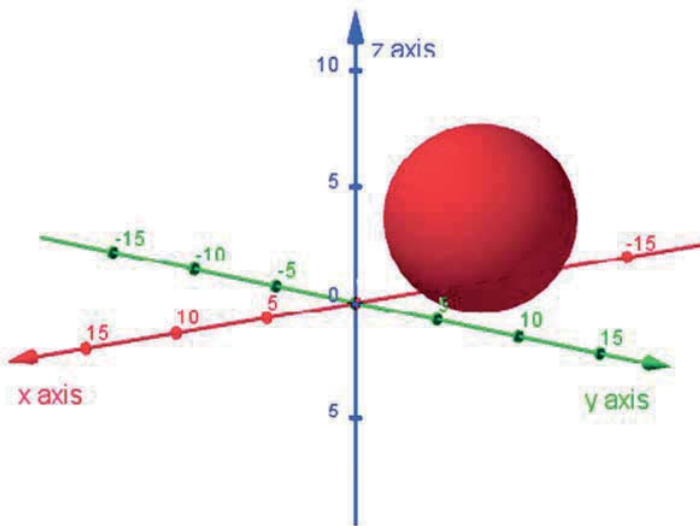

Example 8.58

Find the coordinates of centre and radius of the sphere

$$4x^2 + 4y^2 + 4z^2 - 8x + 16y + 20z + 9 = 0$$

Solution

First, we put this equation in general form by dividing both sides by 4. That is,

$$x^2 + y^2 + z^2 - 2x + 4y + 5z + \frac{9}{4} = 0$$

Now the centre is

$$\left(-\frac{-2}{2}, -\frac{4}{2}, -\frac{5}{2}\right) = \left(1, -2, -\frac{5}{2}\right)$$

The radius is

$$\frac{1}{2} \sqrt{(-2)^2 + 4^2 + 5^2 - 4 \times \frac{9}{4}} = \frac{1}{2} \sqrt{4 + 16 + 25 - 9}$$

Thus, the centre is $\left(1, -2, -\frac{5}{2}\right)$ and the radius is 3.

Alternative method

We could get the centre and radius by completing the squares.

That is

$$4x^2 + 4y^2 + 4z^2 - 8x + 16y + 20z + 9 = 0$$

$$\Rightarrow x^2 + y^2 + z^2 - 2x + 4y + 5z = -\frac{9}{4}$$

$$\Rightarrow x^2 - 2x + y^2 + 4y + z^2 + 5z = -\frac{9}{4}$$

$$\Rightarrow (x-1)^2 - 1 + (y+2)^2 - 4 + \left(z + \frac{5}{2}\right)^2 - \frac{25}{4} = -\frac{9}{4}$$

$$\Rightarrow (x-1)^2 + (y+2)^2 + \left(z + \frac{5}{2}\right)^2 = -\frac{9}{4} + 1 + 4 + \frac{25}{4}$$

$$\Rightarrow (x-1)^2 + (y+2)^2 + \left(z + \frac{5}{2}\right)^2 = \frac{-9 + 4 + 16 + 25}{4}$$

$$\Rightarrow (x-1)^2 + (y+2)^2 + \left(z + \frac{5}{2}\right)^2 = 9$$

$$\Rightarrow (x-1)^2 + (y+2)^2 + \left(z + \frac{5}{2}\right)^2 = 3^2$$

Thus the centre is $\left(1, -2, -\frac{5}{2}\right)$ and the radius is 3.

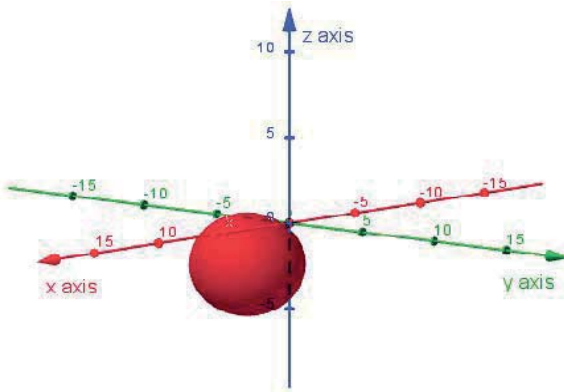

Example 8.59

Find the equation of sphere which passes through the points $(1, 2, 3)$, $(0, -2, 4)$, $(4, -4, 2)$ and $(3, 1, 4)$.

Solution

Let the equation of sphere be $x^2 + y^2 + z^2 + ax + by + cz + d = 0$

Substituting these four points into this equation gives:

$$\begin{cases} 1+4+9+a+2b+3c+d=0 \\ 0+4+16+0-2b+4c+d=0 \\ 16+16+4+4a-4b+2c+d=0 \\ 9+1+16+3a+b+4c+d=0 \end{cases} \Leftrightarrow \begin{cases} a+2b+3c+d=-14 \\ -2b+4c+d=-20 \\ 4a-4b+2c+d=-36 \\ 3a+b+4c+d=-26 \end{cases}$$

Solving gives

$$\begin{cases} a=-4 \\ b=2 \\ c=-2 \\ d=-8 \end{cases}$$

Thus, the equation is $x^2 + y^2 + z^2 - 4x + 2y - 2z - 8 = 0$

Example 8.60

Prove that the equation of sphere described on the line segment joining the points $(2, -1, 4)$ and $(-2, 2, -2)$ as diameter, is

$$x^2 + y^2 + z^2 - y - 2z - 14 = 0$$

Solution

The midpoint of the points $(2, -1, 4)$ and $(-2, 2, -2)$ which is the center of the sphere is

$$\frac{1}{2}(2-2, -1+2, 4-2) = \left(0, \frac{1}{2}, 1\right).$$

The radius of the sphere is a half the distance between the given two points:

$$r = \frac{1}{2}\sqrt{(-2-2)^2 + (2+1)^2 + (-2-4)^2} = \frac{1}{2}\sqrt{16+9+36} = \frac{1}{2}\sqrt{61}$$

The equation of sphere is

$$(x-0)^2 + \left(y-\frac{1}{2}\right)^2 + (z-1)^2 = \left(\frac{1}{2}\sqrt{61}\right)^2$$

Or

$$x^2 + y^2 + z^2 - y - 2z - 14 = 0 \text{ as required.}$$

Application Activity 8.22

1. Find the equation of the sphere with:

- Centre $(1, 2, 3)$ and radius 4
- Centre $(3, -1, 1)$ and radius $\sqrt{3}$
- Centre $(4, 0, -1)$ and radius 7

2. Find the centre and radius of the sphere:

- $x^2 + y^2 + z^2 - 22x - 6y + 66 = 0$
- $x^2 + y^2 + z^2 + 8x - 16y - 14z + 93 = 0$
- $3x^2 + 3y^2 + 3z^2 - 54y - 18z - 318 = 0$

3. Describe the sets of points in space whose coordinates satisfy the given inequalities:

- $x^2 + y^2 + z^2 < 4$
- $x^2 + y^2 + z^2 + 4x - 6y + 8z + 25 \leq 0$
- $x^2 + y^2 + z^2 - 2x + 6y > -2$

8.4.2. Position of point and sphere

Activity 8.23



In each of the following cases, find the distance between the given point P and the centre of the given sphere S . Deduce if the point lies inside the sphere, outside the sphere or on the sphere.

1. $S \equiv (x-1)^2 + (y+2)^2 + (z-2)^2 = 4, \quad P(2,4,3)$

2. $S \equiv (x-3)^2 + (y-2)^2 + (z-1)^2 = 6, \quad P(1,1,0)$

3. $S \equiv (x+2)^2 + y^2 + (z-1)^2 = 37, \quad P(-1,-2,1)$

Consider a sphere S with radius r and centre $\Omega(a,b,c)$ and any point $P(a_1, a_2, a_3)$

- ⊙ If $d(\Omega, P) < r$, the point lies inside the sphere S .
- ⊙ If $d(\Omega, P) = r$, the point lies on the sphere S .
- ⊙ If $d(\Omega, P) > r$, the point lies outside the sphere S .

In all cases, $d(\Omega, P)$ is the distance between point P and centre Ω of sphere S .

Example 8.61

Find the position of point $A(4,5,6)$ and the sphere $(x-2)^2 + (y-1)^2 + (z+1)^2 - 37 = 0$

Solution

Centre of sphere is $(2,1,-1)$ and its radius is $r = \sqrt{37}$.

The distance between the centre of the sphere and the given point is $d = \sqrt{2^2 + 4^2 + 7^2} = \sqrt{69}$

Here $d > r$. Thus, the point lies outside the sphere.

Example 8.62

Describe the position of point $A(1,-2,1)$ and the sphere $(x+1)^2 + (y+2)^2 + (z-1)^2 = 56$

Solution

Centre of sphere is $(-1, -2, 1)$ and its radius is $r = \sqrt{56}$

The distance between the centre of the sphere and the given point is $d = 2$.

Here $d < r$. Thus, the point lies inside the sphere.

Example 8.63

Describe the position of point $P(1, 2, 3)$ and the sphere $x^2 + y^2 + z^2 - 4x + 2y - 2z - 8 = 0$

Solution

Centre of sphere is $\left(\frac{4}{2}, -\frac{2}{2}, \frac{2}{2}\right) = (2, -1, 1)$ and its radius is

$$r = \frac{1}{2} \sqrt{16 + 4 + 4 + 32} = \frac{\sqrt{56}}{2} = \sqrt{14}.$$

The distance between the centre of the sphere and the given point is $d = \sqrt{14}$.

Here $d = r$. Thus, the point lies on the sphere.

Application Activity 8.23

Describe the position of:

1. point $P(2, 3, 4)$ and the sphere $x^2 + y^2 + z^2 - 2y - 6z = -6$
2. point $P(1, 1, 2)$ and the sphere $x^2 + y^2 + z^2 - 2y - 6z = -6$
3. point $P(-1, 2, 0)$ and the sphere $x^2 + y^2 + z^2 + 4x - 2y - 2z + 3 = 0$
4. point $P(6, 3, 1)$ and the sphere $x^2 + y^2 + z^2 + 4x - 2z - 4 = 0$

8.4.3. Position of a sphere and a line

Activity 8.24



In each of the following cases, find the shortest distance between the given line L and the centre of the given sphere S . Deduce if the line is tangent to the sphere, pierces the sphere or doesn't touch the sphere.

$$1. L \equiv \begin{cases} x = 2 + t \\ y = -1 - t \\ z = 3 + 2t \end{cases} \quad S \equiv (x-1)^2 + (y-3)^2 + (z+2)^2 = 81$$

$$2. L \equiv \begin{cases} x = 4t \\ y = -2t \\ z = 2t \end{cases} \quad S \equiv x^2 + y^2 + (z-12)^2 = 4$$

$$3. L \equiv \frac{x-2}{4} = \frac{y-3}{4} = \frac{z-4}{2} \quad S \equiv (x-1)^2 + (y-2)^2 + (z-3)^2 = \frac{3}{4}$$

There are three possible line-sphere intersections:

- ⊙ One point of intersection,
- ⊙ Two points of intersection and
- ⊙ No intersection.

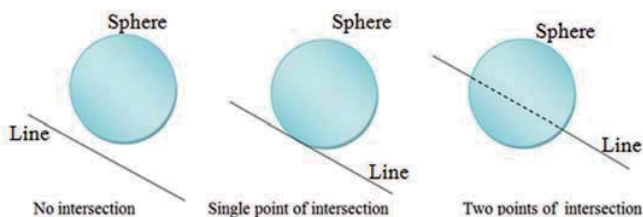

If the line passes through the centre of a sphere, there are two points of intersection and those points are called **antipodal** points. Consider a sphere S with radius r and centre $\Omega(a, b, c)$ and a line L

- ⊙ If $d(\Omega, L) < r$, there are two points of intersection.
- ⊙ If $d(\Omega, L) = r$, there is a single point of intersection.
- ⊙ If $d(\Omega, L) > r$, there is no intersection.

In all cases, $d(\Omega, L)$ is the shortest distance from the centre Ω of sphere S to the line L .

We are interested in the case where the line-plane intersection is a point.

In this case, the line is tangent to the sphere and there is one point of intersection. At this point, there are many lines tangent to the sphere and they are included in the plane tangent to the sphere at this point.

Let the point of intersection be $P(a, b, c)$ and centre of sphere be $\Omega = (k, l, m)$.

The vector $\overrightarrow{\Omega P} = (a - k, b - l, c - m)$ is orthogonal to the line. From this vector, we can find the direction vector of the line.

Example 8.64

Consider the sphere S passing through the point $P(2, -1, 3)$ and with centre $C(1, 2, -3)$. Find the equations of the line D tangents to the sphere S at point P .

Solution

There are many possible answers. First, we need the vector from point P to the centre of the sphere, i.e. $\overrightarrow{CP} = (1, -3, 6)$. Next, we need the vector \vec{u} which is perpendicular to the vector \overrightarrow{CP} and that vector will be the direction vector of line D . Let, take $\vec{u} = (6, 4, 1)$.

So, the line D passing through the point $P(2, -1, 3)$ and with direction vector $\vec{u} = (6, 4, 1)$ has equations

$$D \equiv \begin{cases} x = 2 + 6r \\ y = -1 + 4r \\ z = 3 + r \end{cases}$$

Example 8.65

Consider the sphere $S \equiv x^2 + y^2 + z^2 = 16$ and the line D passing through the points $P(1, 2, -4)$ and $Q(-2, 1, 3)$. Find the common points.

Solution

The direction vector of the line is $\overline{PQ} = (-3, -1, 7)$ and the parametric equations are

$$\begin{cases} x = 1 - 3r \\ y = 2 - r \\ z = -4 + 7r \end{cases}$$

Putting these values into the equation of the sphere, we have

$$(1 - 3r)^2 + (2 - r)^2 + (-4 + 7r)^2 = 16$$

$$\Leftrightarrow 1 - 6r + 9r^2 + 4 - 4r + r^2 + 16 - 56r + 49r^2 = 16$$

$$\Leftrightarrow 59r^2 - 66r + 5 = 0 \Rightarrow r = \frac{33 + \sqrt{794}}{59} \text{ or } r = \frac{33 - \sqrt{794}}{59}$$

If $r = \frac{33 + \sqrt{794}}{59}$, we have

$$\begin{cases} x = 1 - 3\left(\frac{33 + \sqrt{794}}{59}\right) = \frac{-40 - 3\sqrt{794}}{59} \\ y = 2 - \frac{33 + \sqrt{794}}{59} = \frac{85 - \sqrt{794}}{59} \\ z = -4 + 7\left(\frac{33 + \sqrt{794}}{59}\right) = \frac{-5 + 7\sqrt{794}}{59} \end{cases}$$

If $r = \frac{33 - \sqrt{794}}{59}$, we have

$$\begin{cases} x = 1 - 3\left(\frac{33 - \sqrt{794}}{59}\right) = \frac{-40 + 3\sqrt{794}}{59} \\ y = 2 - \frac{33 - \sqrt{794}}{59} = \frac{85 + \sqrt{794}}{59} \\ z = -4 + 7\left(\frac{33 - \sqrt{794}}{59}\right) = \frac{-5 - 7\sqrt{794}}{59} \end{cases}$$

Then there are two points of intersection:

$$\left(\frac{-40 - 3\sqrt{794}}{59}, \frac{85 - \sqrt{794}}{59}, \frac{-5 + 7\sqrt{794}}{59}\right) \text{ and}$$

$$\left(\frac{-40 + 3\sqrt{794}}{59}, \frac{85 + \sqrt{794}}{59}, \frac{-5 - 7\sqrt{794}}{59}\right)$$

Application Activity 8.24

- Find the equation of a sphere of radius 6 which touches the three coordinate axes.
- Find the co-ordinates of the points where the line $\frac{1}{4}(x+3) = \frac{1}{3}(y+4) = -\frac{1}{5}(z-8)$ intersects the sphere $x^2 + y^2 + z^2 + 2x - 10y = 23$.

8.4.4. Position of a sphere and a plane

Activity 8.25



In each of the following cases, find the shortest distance between the given plane α and the centre of the given sphere S . Deduce if the plane is tangent to the sphere, cuts the sphere or doesn't touch the sphere.

- $S \equiv (x-1)^2 + (y+2)^2 + (z-2)^2 = 4$, $\alpha \equiv x + 2y + 3z = 10$
- $S \equiv (x-3)^2 + (y-2)^2 + (z-1)^2 = 6$, $\alpha \equiv -x - 2y + 3z = 12$
- $S \equiv (x+2)^2 + y^2 + (z-1)^2 = 14$, $\alpha \equiv 2x + 3y - z = 9$

Consider a sphere $S \equiv x^2 + y^2 + z^2 + ax + by + cz + d = 0$ with centre $\Omega = (k, l, m)$ and radius r and plane $\alpha \equiv hx + ny + pz = q$, their position appears in three cases.

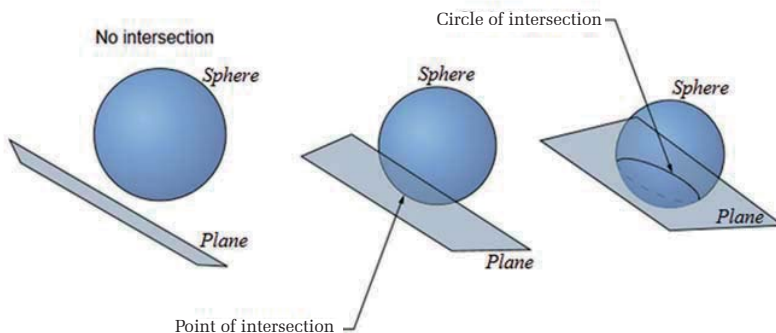

If $d(\Omega, \alpha) < r$, the plane cuts the sphere and the intersection is a circle whose center is on the line through the center of the sphere and perpendicular to the plane. When the plane cuts the sphere, we call it plane section of a sphere.

The normal vector of the plane is the direction vector of this perpendicular line. Since this perpendicular line passes through the centre of the sphere, we can find its parametric equations (having the point and the direction vector). To find the intersection of this line with the plane, we will plug in the values of x, y and z from the parametric equation of the perpendicular line into the equation of the sphere to find the value of the parameter and then that value of the parameter into the parametric equations of the perpendicular line to find the point of intersection which will be the centre of the circle of intersection.

The radius can be found using Pythagorean rule. Since the radius of the sphere and the distance from the centre of the sphere to the plane can be found, if P is the centre of this circle, Ω is the centre of the sphere and Q is any point on the circle which is also a point on the sphere, then $d(\Omega, Q)$ is the radius of the sphere, $d(\Omega, P)$ is the distance from the centre of the sphere to the plane and $d(P, Q)$ is the radius of the circle.

Then $d(P, Q) = \sqrt{[d(\Omega, Q)]^2 - [d(\Omega, P)]^2}$.

Remarks

a) Two equations, one of a sphere and the other of the plane, together represent a circle. Thus,

$$\begin{cases} x^2 + y^2 + z^2 + a_1x + b_1y + c_1z + d_1 = 0 \\ a_2x + b_2y + c_2z + d_2 = 0 \end{cases} \text{ is a circle.}$$

Hence the circle of intersection of the sphere

$$S \equiv x^2 + y^2 + z^2 + ax + by + cz + d = 0 \text{ and the plane}$$

$\alpha \equiv hx + ny + pz = q$, is given by

$$\begin{cases} x^2 + y^2 + z^2 + ax + by + cz + d = 0 \\ hx + ny + pz = q \end{cases}$$

b) If we add a scalar multiple of the second equation using a constant k ,

i.e. $x^2 + y^2 + z^2 + ax + by + cz + d + k(hx + ny + pz - q) = 0$ we will have a sphere.

c) Sphere through a given circle

Given the circle

$$\begin{cases} x^2 + y^2 + z^2 + a_1x + b_1y + c_1z + d_1 = 0 \\ a_2x + b_2y + c_2z + d_2 = 0 \end{cases}$$

The equation of sphere through this circle is

$$x^2 + y^2 + z^2 + a_1x + b_1y + c_1z + d_1 + k(a_2x + b_2y + c_2z + d_2) = 0$$

If $d(\Omega, \alpha) > r$, there is no intersection.

If $d(\Omega, \alpha) = r$, the plane is tangent to the sphere and the intersection, is the point. To find this point of intersection we proceed in the same way as in case 1 above.

The **tangent plane** at point $P(a_1, a_2, a_3)$ on the sphere $x^2 + y^2 + 2kx + 2ly + 2mz + d = 0$ is

$$a_1x + a_2y + a_3z + k(x + a_1) + l(y + a_2) + m(z + a_3) + d = 0$$

In all cases, $d(\Omega, \alpha)$ is the distance from the centre $\Omega = (k, l, m)$ of the sphere $S \equiv x^2 + y^2 + z^2 + ax + by + cz + d = 0$ with radius r to the

plane $\alpha \equiv hx + ny + pz = q$. It is given by $d(\Omega, \alpha) = \frac{|hk + nl + pm - q|}{\sqrt{h^2 + n^2 + p^2}}$.

Note that the section of a sphere by a plane through its centre is known as great circle.

The centre and radius of a great circle are the same as those of the sphere.

Example 8.66

Consider the sphere $S \equiv x^2 + y^2 + z^2 - 2x - 15 = 0$ and the plane $\alpha \equiv 3x - 2y + 5z = 6$. Find their intersection.

Solution

The centre of the sphere is

$$\Omega\left(-\frac{-2}{2}, 0, 0\right) = \Omega(1, 0, 0)$$

The radius of the sphere is

$$\frac{1}{2}\sqrt{(-2)^2 + 0 + 0 + 4 \times 15} = \frac{1}{2}\sqrt{64}$$

$$= 4$$

The distance between the sphere and the plane is

$$\frac{|3+0+0-6|}{\sqrt{9+4+25}} = \frac{3}{\sqrt{38}}$$

$$= \frac{3\sqrt{38}}{38}$$

Since this distance is less than the radius of the sphere, there is a circle of intersection.

Then the radius of the circle of intersection is

$$\sqrt{4^2 - \left(\frac{3}{\sqrt{38}}\right)^2} = \sqrt{16 - \frac{9}{38}}$$

$$= \sqrt{\frac{599}{38}}$$

The normal vector of the plane which is also the direction vector of the perpendicular line of the plane through the centre $(1,0,0)$ of the sphere is $(3,-2,5)$.

Then, the parametric equations of this perpendicular line are

$$\begin{cases} x = 1 + 3r \\ y = -2r \\ z = 5r \end{cases}$$

Putting them into the equation of the plane to find the value of the parameter r gives

$$3(1+3r) - (-2r) + 5(5r) = 6 \Leftrightarrow 3 + 38r = 6 \Leftrightarrow r = \frac{3}{38}$$

Putting this value of r into the parametric equations of the perpendicular line of the plane through the centre of the sphere to find the centre of the circle of intersection gives

$$\begin{cases} x = 1 + 3\left(\frac{3}{38}\right) \\ y = -2\left(\frac{3}{38}\right) \\ z = 5\left(\frac{3}{38}\right) \end{cases} \Leftrightarrow \begin{cases} x = \frac{47}{38} \\ y = \frac{-6}{38} = \frac{-3}{19} \\ z = \frac{15}{38} \end{cases}$$

Then the centre of the circle of the intersection is $\left(\frac{47}{38}, \frac{-3}{19}, \frac{15}{38}\right)$

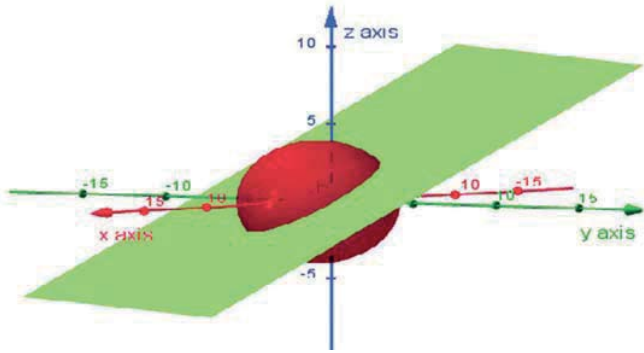

Example 8.67

Consider the plane $\alpha \equiv 2x + y - z = 7$ and the sphere $S \equiv x^2 + y^2 + z^2 - 4x + 6y - 15 = 0$

Find:

- the Cartesian equations of two planes β and γ tangent to the sphere S and parallel to the plane α .
- points of intersection of sphere S with planes β and γ .

Solution

The centre of the sphere is $(2, -3, 0)$ and the radius is

$$\begin{aligned} \frac{1}{2}\sqrt{16+36+60} &= \frac{1}{2}\sqrt{112} \\ &= 2\sqrt{7} \end{aligned}$$

- The equations of the planes β and γ tangent to the sphere S and parallel to the plane α have the form $2x + y - z = k$. The distance from the centre of the sphere to each plane β or γ is equal to the radius of the sphere.

That is;

$$\frac{|4-3+0-k|}{\sqrt{4+1+1}} = 2\sqrt{7} \quad \Leftrightarrow \quad \frac{|1-k|}{\sqrt{6}} = 2\sqrt{7}$$

$$\Leftrightarrow |1-k| = 2\sqrt{42} \quad \Leftrightarrow 1-k = 2\sqrt{42} \quad \text{or} \quad 1-k = -2\sqrt{42}$$

$$\Leftrightarrow k = 1+2\sqrt{42} \quad \text{or} \quad k = 1-2\sqrt{42}.$$

Thus, the two planes are

$$\beta \equiv 2x + y - z = 1 + 2\sqrt{42} \quad \text{and} \quad \gamma \equiv 2x + y - z = 1 - 2\sqrt{42}.$$

- b) These two points lie on the perpendicular line of planes β and γ passing through the centre of the sphere $(2, -3, 0)$ and the direction vector of this perpendicular is the normal vector for the two planes which is $(2, 1, -1)$.

The parametric equations for this line are

$$\begin{cases} x = 2 + 2r \\ y = -3 + r \\ z = -r \end{cases}$$

Putting these values of x, y and z into $\beta \equiv 2x + y - z = 1 + 2\sqrt{42}$ gives

$$4 + 4r - 3 + r + r = 1 + 2\sqrt{42} \Rightarrow r = \frac{\sqrt{42}}{3} \quad \text{and}$$

putting them into $\gamma \equiv 2x + y - z = 1 - 2\sqrt{42}$ gives

$$4 + 4r - 3 + r + r = 1 - 2\sqrt{42} \Rightarrow r = -\frac{\sqrt{42}}{3}.$$

Putting these two values of the parameter into the parametric equations of the perpendicular line gives:

$$\begin{cases} x = 2 + \frac{2\sqrt{42}}{3} \\ y = -3 + \frac{\sqrt{42}}{3} \\ z = -\frac{\sqrt{42}}{3} \end{cases} \Leftrightarrow \begin{cases} x = \frac{6 + 2\sqrt{42}}{3} \\ y = \frac{-9 + \sqrt{42}}{3} \\ z = -\frac{\sqrt{42}}{3} \end{cases} \quad \text{and}$$

$$\begin{cases} x = 2 - \frac{2\sqrt{42}}{3} \\ y = -3 - \frac{\sqrt{42}}{3} \\ z = \frac{\sqrt{42}}{3} \end{cases} \Leftrightarrow \begin{cases} x = \frac{6 - 2\sqrt{42}}{3} \\ y = \frac{-9 - \sqrt{42}}{3} \\ z = \frac{\sqrt{42}}{3} \end{cases}$$

Thus, the two points of intersection are

$$\left(\frac{6 + 2\sqrt{42}}{3}, \frac{-9 + \sqrt{42}}{3}, -\frac{\sqrt{42}}{3} \right) \text{ and}$$

$$\left(\frac{6 - 2\sqrt{42}}{3}, \frac{-9 - \sqrt{42}}{3}, \frac{\sqrt{42}}{3} \right)$$

Example 8.68

Find the equation to a sphere which passes through the circle

$$\begin{cases} x^2 + y^2 + z^2 - 2x + 2y + 4z - 3 = 0 \\ 2x + y + z = 4 \end{cases} \text{ and through the point } (1, 2, -1).$$

Solution

The equation of the sphere passing through the given circle is

$$x^2 + y^2 + z^2 - 2x + 2y + 4z - 3 + k(2x + y + z - 4) = 0$$

This sphere passes through the point $(1, 2, -1)$, so,

$$1 + 4 + 1 - 2 + 4 - 4 - 3 + k(2 + 2 - 1 - 4) = 0 \text{ or } k = 1$$

Hence, the equation is

$$x^2 + y^2 + z^2 - 2x + 2y + 4z - 3 + 1(2x + y + z - 4) = 0 \text{ or}$$

$$x^2 + y^2 + z^2 + 3y + 5z - 7 = 0$$

Example 8.69

Find the centre and the radius of the circle

$$\begin{cases} x^2 + y^2 + z^2 - 2y - 4z = 11 \\ x + 2y + 2z = 15 \end{cases}$$

Solution

The given circle is the intersection of sphere

$$S \equiv x^2 + y^2 + z^2 - 2y - 4z = 11 \text{ and plane } \alpha \equiv x + 2y + 2z = 15.$$

The centre of this sphere is $\Omega = (0, 1, 2)$ and its radius is $r = 4$.

Equation of the line through the centre of the sphere and perpendicular to the plane are

$$\begin{cases} x = t \\ y = 1 + 2t \\ z = 2 + 2t \end{cases}$$

Putting these values into the equation of the sphere we will have the centre of the circle:

$t + 2 + 4t + 4 + 4t = 15$ or $t = 1$. Substituting this value of t in equation of line gives the centre of the circle which is $(1, 3, 4)$.

The radius of the circle:

The distance of the centre of the sphere from the plane is

$$d = \frac{|0 + 2 + 4 - 15|}{\sqrt{9}} = \frac{9}{3} = 3$$

Then the radius of the circle is $\sqrt{4^2 - 3^2} = \sqrt{7}$.

Example 8.70

Find the equation of the tangent plane to the sphere

$$x^2 + y^2 + z^2 + 2x + 4y - 6z - 6 = 0 \text{ at } (1, 2, 3)$$

Solution

We see that:

$$k = 1, l = 2, m = -3 \quad a_1 = 1, a_2 = 2, a_3 = 3$$

$$x + 2y + 3z + (x+1) + 2(y+2) - 3(z+3) - 6 = 0$$

$$\Leftrightarrow x + 2y + 3z + x + 1 + 2y + 4 - 3z - 9 - 6 = 0 \text{ the required equation is } 2x + 4y - 10 = 0$$

Alternative method

The vector formed by the point $(1, 2, 3)$ and the centre of sphere is the normal vector of the needed plane.

Centre of sphere is $(-1, -2, 3)$. Normal vector is $\vec{n} = (-2, -4, 0)$

Since the plane passes through the point $(1, 2, 3)$ then the required equation is

$$-2(x-1) - 4(y-2) + 0(z-3) = 0$$

$$\Leftrightarrow -2x + 2 - 4y + 8 = 0$$

$$\Leftrightarrow -2x - 4y + 10 = 0$$

Or

$$2x + 4y - 10 = 0$$

Application Activity 8.25

- Find the tangent planes to the sphere $x^2 + y^2 + z^2 - 4x + 2y - 6z + 5 = 0$ which are parallel to the plane $2x + 2y - z = 0$.
- Find the equations of two tangent planes to the sphere $x^2 + y^2 + z^2 = 9$ which passes through the line $x + y = 6, x - 2z = 3$.
- Find the equations of spheres passing through the circle $x^2 + y^2 + z^2 - 6x - 2z + 5 = 0, y = 0$ and touching the plane $3y + 4z + 5 = 0$.
- Find the equations of the spheres which pass through the circle $x^2 + y^2 + z^2 - 4x - y + 3z + 12 = 0, 2x + 3y - 7z = 10$ and touch the plane $x - 2y + 2z = 1$.

8.4.5. Position of two spheres



Activity 8.26

In each of the following cases, find the shortest distance between the centres of the given spheres S_1 and S_2 . Compare the obtained distance and the sum of their radii. What can you say about their position?

- $$S_1 \equiv (x-1)^2 + (y+2)^2 + (z-2)^2 = 4,$$

$$S_2 \equiv (x+2)^2 + (y+1)^2 + (z-1)^2 = 9$$
- $$S_1 \equiv (x-3)^2 + (y-2)^2 + (z-1)^2 = 25,$$

$$S_2 \equiv (x-4)^2 + (y+6)^2 + (z-5)^2 = 16$$
- $$S_1 \equiv (x+2)^2 + (y-4)^2 + (z-1)^2 = 3,$$

$$S_2 \equiv (x-1)^2 + (y+2)^2 + (z-2)^2 = 4$$

Consider two spheres with centers C_1 and C_2 ; radii r_1 and r_2 . The position of these two spheres depends on the distance between their centers $d(C_1, C_2)$

Case 1: $d=r_1+r_2$: tangent exterior

$d=|r_1-r_2|$: tangent interior

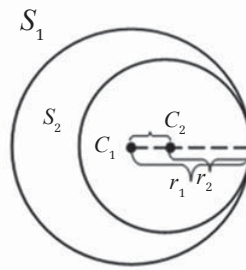
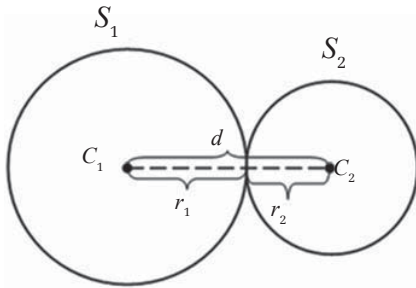

The intersection is a point

Case 2: $|r_1 - r_2| < d < r_1 + r_2$

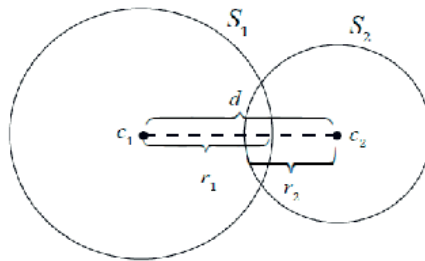
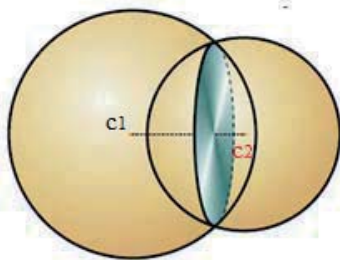

The intersection is a circle

Case 3: $d > r_1 + r_2$: exterior

$d < |r_1 - r_2|$: interior

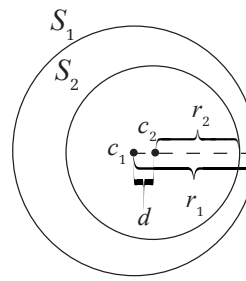
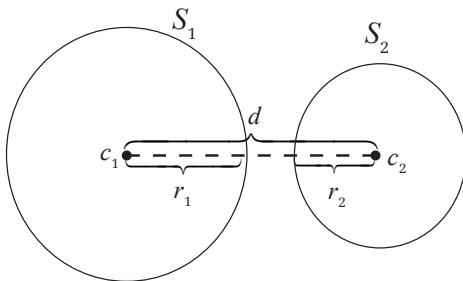

No intersection

- ⊙ If $d > r_1 + r_2$
Two spheres are exterior and hence no intersection.
- ⊙ If $d < |r_1 - r_2|$
Two spheres are interior and hence no intersection.
- ⊙ If $d = r_1 + r_2$.
Two spheres are tangent exterior and hence there is a point of intersection.

To find this point of intersection:

We can find, by writing the parametric equations, the line through the two centers of two spheres. Intersect that line with the two spheres we obtain four points of intersection (two for each sphere). Among these four points, the common point will be the point of intersection of two spheres.

Or

We subtract one equation of the sphere from the other to obtain a plane tangent to both spheres at the point of intersection. The intersection of this plane with one of the two spheres is the intersection of two spheres (we are on the case of sphere-plane intersection where the plane is tangent to the sphere).

⊙ If $d = |r_1 - r_2|$

Two spheres are tangent interior and hence there is a point of intersection.

To find this point of intersection use the same method as in the case above.

⊙ If $|r_1 - r_2| < d < r_1 + r_2$

One sphere cuts another. The intersection is a circle.

Given two spheres we subtract one from the other to obtain a plane. In this plane lies a circle that is the circle where the two spheres intersect. The task here is to somehow parameterize a curve that will generate explicitly the points on this circle. Call the centre of the circle of intersection and its radius, say C and R respectively. Now we are on the case of sphere-plane intersection.

We can find by writing the parametric equations of the line through the two centers of two spheres. Intersect that line with the plane of intersection and obtain the point which will be the centre of the circle of intersection.

Likewise we can determine the radius of the circle by using the Pythagorean Theorem in the following way: determine the distance of the centre of one of the spheres from the obtained plane.

This is one leg of a right triangle. The desired radius is the other leg. The radius of the sphere is the hypotenuse.

Remark**a) Sphere through the intersection of two spheres**

Given two spheres

$$x^2 + y^2 + z^2 + a_1x + b_1y + c_1z + d_1 = 0 \text{ and}$$

$$x^2 + y^2 + z^2 + a_2x + b_2y + c_2z + d_2 = 0$$

The equation of sphere through the intersection of these two spheres is

$$x^2 + y^2 + z^2 + a_1x + b_1y + c_1z + d_1 + k(x^2 + y^2 + z^2 + a_2x + b_2y + c_2z + d_2) = 0$$

b) Angle of intersection of two spheres

Angle of intersection of two spheres at a common point is the angle between the tangent planes to them at that point, and is, therefore, also equal to the angle between the radii of the spheres to the common point; since the radii being perpendicular to the respective tangent planes at the point.

c) Condition of orthogonality of two spheres

Given two spheres

$$x^2 + y^2 + z^2 + a_1x + b_1y + c_1z + d_1 = 0 \text{ and}$$

$$x^2 + y^2 + z^2 + a_2x + b_2y + c_2z + d_2 = 0$$

If the angle of intersection is a right angle the two spheres are said to be orthogonal.

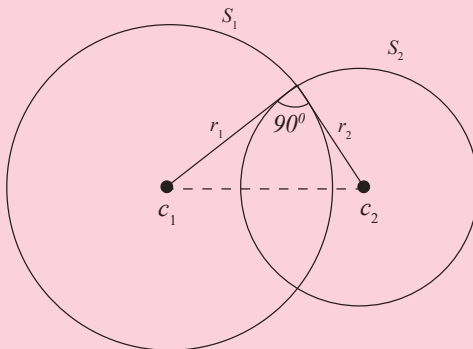

The condition is $r_1^2 + r_2^2 = (c_1c_2)^2$

Example 8.71

Sphere S_1 has centre $C_1(3, -2, 5)$ and radius 4. Find the equation of sphere S_2 with centre $C_2(7, 6, -8)$ tangents to S_1 exterior.

Solution

First we calculate the distance between the centers:

$$\begin{aligned} d(C_1, C_2) &= \sqrt{4^2 + 8^2 + (-13)^2} \\ &= \sqrt{249} \end{aligned}$$

Since one sphere is tangent to another exterior the radius of S_2 is $\sqrt{249} - 4$.

The equation of S_2 is $(x-7)^2 + (y-6)^2 + (z+8)^2 = (\sqrt{249} - 4)^2$

Or

$$x^2 + y^2 + z^2 - 14x - 12y + 16z + \sqrt{249} - 116 = 0$$

Example 8.72

Find the intersection between sphere $S_1 \equiv x^2 + y^2 + z^2 - 2y = 8$ and $S_2 \equiv x^2 + y^2 + z^2 - 12x - 2y = -33$

Solution

For $S_1 \equiv x^2 + y^2 + z^2 - 2y = 8$:

Centre is $C_1 = \left(\frac{0}{2}, \frac{2}{2}, \frac{0}{2}\right) = (0, 1, 0)$,

Radius is $R_1 = \frac{1}{2}\sqrt{0+4+0+32} = 3$

For $S_2 \equiv x^2 + y^2 + z^2 - 12x - 2y = -33$:

Centre is $C_2 = \left(\frac{12}{2}, \frac{2}{2}, \frac{0}{2}\right) = (6, 1, 0)$,

Radius is $R_2 = \frac{1}{2}\sqrt{144+4+0-132} = 2$

$$d(C_1, C_2) = \sqrt{6^2 + 0 + 0} = 6$$

$$R_1 + R_2 = 3 + 2 = 5$$

$$d(C_1, C_2) > R_1 + R_2$$

Then the two spheres are exterior and hence no intersection between them.

Example 8.73

Find the intersection between sphere $S_1 \equiv x^2 + y^2 + z^2 - 2x - 2y = 34$ and $S_2 \equiv x^2 + y^2 + z^2 - 8x - 2y = -13$

Solution

For $S_1 \equiv x^2 + y^2 + z^2 - 2x - 2y = 34$:

$$\text{Centre is } C_1 = \left(\frac{2}{2}, \frac{2}{2}, \frac{0}{2} \right) = (1, 1, 0),$$

$$\text{Radius is } R_1 = \frac{1}{2} \sqrt{4 + 4 + 0 + 136} = 6$$

For $S_2 \equiv x^2 + y^2 + z^2 - 8x - 2y = -13$:

$$\text{Centre is } C_2 = \left(\frac{8}{2}, \frac{2}{2}, \frac{0}{2} \right) = (4, 1, 0),$$

$$\text{Radius is } R_2 = \frac{1}{2} \sqrt{64 + 4 + 0 - 52} = 2$$

$$d(C_1, C_2) = \sqrt{3^2 + 0 + 0} = 3$$

$$R_1 + R_2 = 6 + 2 = 8$$

$$d(C_1, C_2) < R_1 + R_2.$$

We need to know if $|R_1 - R_2| < d(C_1, C_2)$ or not.

$$|R_1 - R_2| = |6 - 2| = 4.$$

$$|R_1 - R_2| > d(C_1, C_2)$$

Then the two spheres are interior and hence no intersection between them.

Example 8.74

Find the intersection between sphere

$$S_1 \equiv x^2 + y^2 + z^2 + 2x - 6y + 1 = 0 \text{ and}$$

$$S_2 \equiv 4x^2 + 4y^2 + 4z^2 + 10x - 25y - 2z = 0$$

Solution

For $S_1 \equiv x^2 + y^2 + z^2 + 2x - 6y + 1 = 0$:

$$\text{Centre is } C_1 = \left(-\frac{2}{2}, \frac{6}{2}, \frac{0}{2} \right) = (-1, 3, 0),$$

$$\text{Radius is } R_1 = \frac{1}{2} \sqrt{4 + 36 + 0 - 4} = 3$$

For $S_2 \equiv 4x^2 + 4y^2 + 4z^2 + 10x - 25y - 2z = 0$:

$$\text{Centre is } C_2 = \left(-\frac{5}{4}, \frac{25}{8}, \frac{1}{4} \right),$$

$$\text{Radius is } R_2 = \frac{1}{2} \sqrt{\frac{25}{4} + \frac{625}{16} + \frac{1}{4} - 0} = \frac{1}{2} \times \frac{27}{4} = \frac{27}{8}$$

$$d(C_1, C_2) = \sqrt{\left(\frac{-1}{4}\right)^2 + \left(\frac{1}{8}\right)^2 + \left(\frac{1}{4}\right)^2} = \frac{3}{8}$$

$$R_1 + R_2 = 3 + \frac{27}{8} = \frac{51}{8}, \quad |R_1 - R_2| = \left| 3 - \frac{27}{8} \right| = \left| -\frac{3}{8} \right| = \frac{3}{8}$$

Then $d(C_1, C_2) = |R_1 - R_2|$, means that the two spheres are tangent interior. There is a point of intersection.

The plane, say α , through the point of intersection is given by $S_1 - S_2$. i.e, $\alpha \equiv -2x + y + 2z + 4 = 0$.

The normal vector of this plane is the direction vector of its perpendicular line which passes through the centers of the two spheres (the vector formed by the two centers is also a direction vector of this line).

The parametric equations of this line (taking the centre of the first sphere to be the point on the line) are

$$\begin{cases} x = -1 - 2t \\ y = 3 + t \\ z = 2t \end{cases}$$

Intersecting this line and the plane will give us a point of intersection of two spheres:

Putting the equations of the line into the equation of the plane gives

$$2 + 4t + 3 + t + 4t = -4$$

Or

$t = -1$ and then

$$\begin{cases} x = 1 \\ y = 2 \\ z = -2 \end{cases}$$

Hence, the point of intersection for the given spheres is $(1, 2, -2)$.

Example 8.75

Find the intersection between sphere

$$S_1 \equiv x^2 + y^2 + z^2 + 10y - 4z - 8 = 0 \text{ and } S_2 \equiv x^2 + y^2 + z^2 + 6z - 4 = 0.$$

Solution

$$\text{For } S_1 \equiv x^2 + y^2 + z^2 + 10y - 4z - 8 = 0,$$

$$c_1 = (0, -5, 2) \text{ and } r_1 = \sqrt{37}$$

$$\text{For } S_2 \equiv x^2 + y^2 + z^2 + 6z - 4 = 0,$$

$$c_2 = (0, 0, -3) \text{ and } r_2 = \sqrt{13}$$

$$\text{Distance between centers: } c_1c_2 = \sqrt{25 + 25} = 5\sqrt{2}$$

$$r_1 + r_2 = \sqrt{37} + \sqrt{13} \text{ and then } d < r_1 + r_2$$

$$|r_1 - r_2| = |\sqrt{37} - \sqrt{13}| \text{ and then } |r_1 - r_2| < d.$$

$$\text{We see that } |r_1 - r_2| < d < r_1 + r_2.$$

Thus, there is a circle of intersection.

The plane through the intersection is $\alpha \equiv S_1 - S_2$, that is

$$\alpha \equiv 5y - 5z - 2 = 0.$$

Taking $S_1 \equiv x^2 + y^2 + z^2 + 10y - 4z - 8 = 0$ and $\alpha \equiv 5y - 5z - 2 = 0$, the circle of intersection is given by

$$\begin{cases} x^2 + y^2 + z^2 + 10y - 4z - 8 = 0 \\ 5y - 5z - 2 = 0 \end{cases}$$

To find the centre of this circle we need a perpendicular line through the centre of S_1 . The normal vector of plane α is the direction vector of this perpendicular line. Then this perpendicular line has equations:

$$\begin{cases} x = 0 \\ y = -5 + 5t \\ z = 2 - 5t \end{cases}$$

The centre of the circle is the intersection of this line and plane α .

Putting these parametric equations of the perpendicular line into the equation of the plane α gives:

$$5(-5 + 5t) - 5(2 - 5t) - 2 = 0 \Rightarrow t = \frac{37}{50} \text{ and then}$$

$$\begin{cases} x = 0 \\ y = -5 + 5 \times \frac{37}{50} = -\frac{13}{10} \\ z = 2 - 5 \times \frac{37}{50} = -\frac{17}{10} \end{cases}$$

Thus, the centre of the circle is $\left(0, -\frac{13}{10}, -\frac{17}{10}\right)$.

To find the radius of the circle of intersection we need the length from the centre of sphere S_1 to the plane α .

$$\text{This length is } d_1(c_1, \alpha) = \frac{|-25 - 10 - 2|}{\sqrt{5 + 25}} = \frac{37}{\sqrt{50}}$$

Or

The length from the centre of sphere S_1 to the plane α is given by the distance between the centre of sphere S_1 and the centre of the circle of intersection since this circle lies on plane α .

That is

$$\begin{aligned} d_1(c_1, \alpha) &= \sqrt{0 + \left(-5 + \frac{13}{10}\right)^2 + \left(2 + \frac{17}{10}\right)^2} \\ &= \sqrt{\frac{1369}{100} + \frac{369}{100}} \\ &= \frac{37}{\sqrt{50}} \end{aligned}$$

Now, the radius of the circle of intersection is

$$\sqrt{r_1^2 - d_1^2} = \sqrt{37 - \frac{369}{50}} = \sqrt{\frac{481}{50}} = \frac{1}{5} \sqrt{481}.$$

Note that the circle of intersection can also be defined by the equation of sphere S_2 and plane α . That is, circle of intersection is given by

$$\begin{cases} x^2 + y^2 + z^2 + 6z - 4 = 0 \\ 5y - 5z - 2 = 0 \end{cases}$$

Using the same method, the centre and the radius will be the same.

Example 8.76

Find the equation of the sphere through the circle $x^2 + y^2 + z^2 = 4, z = 0$ cutting the sphere $x^2 + y^2 + z^2 + 10y - 4z - 8 = 0$, orthogonally.

Solution

The centre of $x^2 + y^2 + z^2 + 10y - 4z - 8 = 0$ is

$$c_1 = \left(\frac{0}{2}, -\frac{10}{2}, \frac{4}{2} \right) = (0, -5, 2) \text{ and its radius is}$$

$$r_1 = \frac{1}{2} \sqrt{0+100+16+32} = \frac{1}{2} \sqrt{148} = \sqrt{37}.$$

The equation of sphere through the circle $x^2 + y^2 + z^2 = 4, z = 0$ has the form $x^2 + y^2 + z^2 - 4 + kz = 0$ or $x^2 + y^2 + z^2 + kz - 4 = 0$. The centre of this sphere is $c_2 = \left(0, 0, -\frac{k}{2} \right)$ and its radius is $r_2 = \frac{1}{2} \sqrt{k^2 + 16}$.

Since the sphere $x^2 + y^2 + z^2 + kz - 4 = 0$ cuts the sphere $x^2 + y^2 + z^2 + 10y - 4z - 8 = 0$ orthogonally, $r_1^2 + r_2^2 = (c_1 c_2)^2$.

$$(c_1 c_2)^2 = 0 + 25 + \left(-\frac{k}{2} - 2 \right)^2 = 25 + \left(\frac{k}{2} + 2 \right)^2$$

$$r_1^2 + r_2^2 = 37 + \frac{1}{4}(k^2 + 16)$$

Now,

$$\begin{aligned} 25 + \left(\frac{k}{2} + 2 \right)^2 &= 37 + \frac{1}{4}(k^2 + 16) \Leftrightarrow 25 + \frac{k^2}{4} + 2k + 4 = 37 + \frac{k^2}{4} + 4 \\ \Leftrightarrow 2k &= 12 \Rightarrow k = 6 \end{aligned}$$

Hence, the required equation of the sphere is

$$x^2 + y^2 + z^2 + 6z - 4 = 0.$$

Example 8.77

Find the equation of the sphere which passes through the circle $x^2 + y^2 + z^2 - 4x - y + 3z + 12 = 0, 2x + 3y - 7z = 10$ and touch the plane $x - 2y + 2z = 1$.

Solution

The sphere through the circle

$$x^2 + y^2 + z^2 - 4x - y + 3z + 12 = 0, 2x + 3y - 7z = 10 \text{ has the form}$$

$$x^2 + y^2 + z^2 - 4x - y + 3z + 12 + k(2x + 3y - 7z - 10) = 0 \text{ or}$$

$$x^2 + y^2 + z^2 - 4x - y + 3z + 12 + 2kx + 3ky - 7kz - 10k = 0 \text{ or}$$

$$x^2 + y^2 + z^2 + (2k - 4)x + (3k - 1)y + (-7k + 3)z - 10k + 12 = 0$$

$$\text{Its centre is } \left(-k + 2, -\frac{3k}{2} + \frac{1}{2}, \frac{7k}{2} - \frac{3}{2} \right)$$

$$\text{Its radius is } \frac{1}{2} \sqrt{(2k - 4)^2 + (3k - 1)^2 + (-7k + 3)^2 + 40k - 48}$$

$$\Leftrightarrow \frac{1}{2} \sqrt{4k^2 - 16k + 16 + 9k^2 - 6k + 1 + 49k^2 - 42k + 9 + 40k - 48}$$

$$\Leftrightarrow \frac{1}{2} \sqrt{62k^2 - 24k - 22}$$

Since the sphere touches the given plane then the length of the perpendicular (distance between the plane and the centre of the sphere) should be equal to the radius of the sphere.

The length of the perpendicular is

$$\frac{\left| -k + 2 - 2\left(-\frac{3k}{2} + \frac{1}{2}\right) + 2\left(\frac{7k}{2} - \frac{3}{2}\right) - 1 \right|}{\sqrt{1 + 4 + 4}} = \frac{|-k + 2 + 3k - 1 + 7k - 3 - 1|}{3} = \frac{|9k - 3|}{3}$$

$$\text{Now, } \frac{|9k - 3|}{3} = \frac{1}{2} \sqrt{62k^2 - 24k - 22}$$

$$\Leftrightarrow \frac{81k^2 - 54k + 9}{9} = \frac{62k^2 - 24k - 22}{4}$$

$$324k^2 - 216k + 36 = 558k^2 - 216k - 198 \Leftrightarrow 234k^2 - 234 = 0 \Leftrightarrow 13k^2 - 13 = 0 \Rightarrow k = \pm 1$$

Hence the required equations are

$$x^2 + y^2 + z^2 - 2x + 2y - 4z + 2 = 0 \text{ and}$$

$$x^2 + y^2 + z^2 - 6x - 4y + 10z + 22 = 0$$

Application Activity 8.26

1. Find the equation to a sphere which passes through the circle $x^2 + y^2 + z^2 - 2x + 2y + 4z - 3 = 0$, $2x + y + z = 4$ and through the point $(1, 2, -1)$
2. Obtain the equations to the sphere through the common circle of the sphere $x^2 + y^2 + z^2 + 2x + 2y = 0$ and the plane $x + y + z + 4 = 0$ and which intersects the plane $x + y = 0$ in a circle of radius 3 units.
3. Find the equation of the sphere having its centre on the plane $4x - 5y - z = 3$ and passing through the circle $x^2 + y^2 + z^2 - 2x - 3y + 4z + 8 = 0$, $x - 2y + z = 8$

Unit Summary

1. Let the points (x_1, y_1, z_1) and (x_2, y_2, z_2) be the end-points of a line segment, then the midpoint of that segment is given by the formula:

$$\left(\frac{x_1 + x_2}{2}, \frac{y_1 + y_2}{2}, \frac{z_1 + z_2}{2} \right)$$

2. Let $(x_1, y_1, z_1), (x_2, y_2, z_2), \dots, (x_n, y_n, z_n)$ be n points of space, their centroid is given by the formula:

$$\left(\frac{x_1 + x_2 + \dots + x_n}{n}, \frac{y_1 + y_2 + \dots + y_n}{n}, \frac{z_1 + z_2 + \dots + z_n}{n} \right)$$

3. If P is a point on the line AB such that P divides AB

internally in the ratio $m:n$, then $P = \frac{mB + nA}{m+n}$ and if P divides AB externally in the ratio $m:n$, then $P = \frac{mB - nA}{m - n}$.

4. If a line is parallel to the vector $\vec{v} = (a, b, c)$ and passes through the point P with position vector $\vec{OP} = (x_0, y_0, z_0)$, the equation $\vec{OQ} = \vec{OP} + r\vec{v}$ or $(x, y, z) = (x_0, y_0, z_0) + r(a, b, c)$ or $x\vec{i} + y\vec{j} + z\vec{k} = x_0\vec{i} + y_0\vec{j} + z_0\vec{k} + r(a\vec{i} + b\vec{j} + c\vec{k})$ is called the vector equation of this line, where r is a parameter.

The parametric equations of this line are

$$\begin{cases} x = x_0 + ra \\ y = y_0 + rb \\ z = z_0 + rc \end{cases}$$

The Cartesian equations (or symmetric equations) of this line are

$$\frac{x - x_0}{a} = \frac{y - y_0}{b} = \frac{z - z_0}{c}$$

5. For the line passing through points $P(x_0, y_0, z_0)$ and $Q(x_1, y_1, z_1)$ and $V(x, y, z)$ is any point on the line
Vector equation is $\overrightarrow{PV} = r\overrightarrow{PQ}$, where r is a parameter.

Parametric equations:

The symmetric equations:

$$\begin{cases} x = x_0 + r(x_1 - x_0) \\ y = y_0 + r(y_1 - y_0) \\ z = z_0 + r(z_1 - z_0) \end{cases} \quad \frac{x - x_0}{x_1 - x_0} = \frac{y - y_0}{y_1 - y_0} = \frac{z - z_0}{z_1 - z_0}$$

6. The general equation of a straight line in space is

$$\begin{cases} a_1x + b_1y + c_1z = d_1 \\ a_2x + b_2y + c_2z = d_2 \end{cases}$$

The direction vector of this line is

$$\left(\begin{vmatrix} b_1 & c_1 \\ b_2 & c_2 \end{vmatrix}, - \begin{vmatrix} a_1 & c_1 \\ a_2 & c_2 \end{vmatrix}, \begin{vmatrix} a_1 & b_1 \\ a_2 & b_2 \end{vmatrix} \right)$$

7. In 3-dimensional space, there is one more possibility: two lines may be **skew**, which means they do not intersect, but are not parallel.
8. The three points (a_1, a_2, a_3) ; (b_1, b_2, b_3) and (c_1, c_2, c_3) are collinear (meaning that they lie on the same line) if the following conditions are satisfied

$$\begin{vmatrix} a_1 & b_1 & c_1 \\ a_2 & b_2 & c_2 \\ 1 & 1 & 1 \end{vmatrix} = \begin{vmatrix} a_1 & b_1 & c_1 \\ a_3 & b_3 & c_3 \\ 1 & 1 & 1 \end{vmatrix} = 0$$

9. The two lines are parallel if their direction vectors are scalar multiples. If two lines are parallel, there are two possible cases: the lines may be identical or strictly parallel. If you find a point on one line which does not lie on the other, the two lines are strictly parallel but if you find a point on one line which lie on the other, the lines are identical.
10. The angle between two lines is the acute angle (angle which lies between 0 and 90 degrees) between their direction vectors, say \vec{u} and \vec{v} , placed tail to tail. The angle between the lines is found by working out the dot product of \vec{u} and \vec{v} . We have $\vec{u} \cdot \vec{v} = \|\vec{u}\| \|\vec{v}\| \cos \theta$.

11. The distance from point $B(b_1, b_2, b_3)$ the line passing through point $A(a_1, a_2, a_3)$ with direction vector $\vec{u} = (c_1, c_2, c_3)$

$$\text{is } \frac{\|\overrightarrow{AB} \times \vec{u}\|}{\|\vec{u}\|}.$$

12. The shortest distance between two skew lines $L_1: \vec{r} = \vec{a} + \lambda \vec{u}$ and $L_2: \vec{r} = \vec{b} + \lambda \vec{v}$ is given by

$$\|\overrightarrow{PQ}\| = \frac{\|\vec{ab} \cdot \vec{w}\|}{\|\vec{w}\|} = \frac{\|(\vec{b} - \vec{a}) \cdot \vec{u} \times \vec{v}\|}{\|\vec{w}\|}.$$

13. If $P(x_0, y_0, z_0)$ is a point on a plane and $\vec{u} = (x_1, y_1, z_1)$, $\vec{v} = (x_2, y_2, z_2)$ are two direction vectors and $X(x, y, z)$ define any point on this plane.

Vector equation is $\overrightarrow{PX} = r\vec{u} + s\vec{v}$ where r and s are parameters.

Parametric equations:

$$\begin{cases} x = x_0 + rx_1 + sx_2 \\ y = y_0 + ry_1 + sy_2 \\ z = z_0 + rz_1 + sz_2 \end{cases}$$

Cartesian equation is obtained by finding the determinant

$$\begin{vmatrix} x - x_0 & x_1 & x_2 \\ y - y_0 & y_1 & y_2 \\ z - z_0 & z_1 & z_2 \end{vmatrix} = 0$$

We can also find the Cartesian equation by the following determinant:

$$\begin{vmatrix} x & x_0 & x_1 & x_2 \\ y & y_0 & y_1 & y_2 \\ z & z_0 & z_1 & z_2 \\ 1 & 1 & 0 & 0 \end{vmatrix} = 0$$

14. If $P(x_0, y_0, z_0)$ and $Q(x_1, y_1, z_1)$ are two points of a plane whose direction vector is $\vec{v} = (x_2, y_2, z_2)$ and $X(x, y, z)$ define any point on this plane then Vector equation is $\overrightarrow{PX} = r\overrightarrow{PQ} + s\vec{v}$ where r and s are parameters

Parametric equations

$$\begin{cases} x = x_0 + r(x_1 - x_0) + sx_2 \\ y = y_0 + r(y_1 - y_0) + sy_2 \\ z = z_0 + r(z_1 - z_0) + sz_2 \end{cases}$$

Cartesian equation is found by finding the following determinant

$$\begin{vmatrix} x - x_0 & x_1 - x_0 & x_2 \\ y - y_0 & y_1 - y_0 & y_2 \\ z - z_0 & z_1 - z_0 & z_2 \end{vmatrix} = 0$$

Or we can use the determinant

$$\begin{vmatrix} x & x_0 & x_1 & x_2 \\ y & y_0 & y_1 & y_2 \\ z & z_0 & z_1 & z_2 \\ 1 & 1 & 1 & 0 \end{vmatrix} = 0$$

We can also find the Cartesian equation by finding the value of two parameters in first two equation of parametric equations and put them in the third equation.

15. If $P(x_0, y_0, z_0)$, $Q(x_1, y_1, z_1)$ and $N(x_2, y_2, z_2)$ are three points of a plane and $X(x, y, z)$ define any point on this plane then

Vector equation is $\overrightarrow{PX} = r\overrightarrow{PQ} + s\overrightarrow{PN}$ where r and s are parameters

Parametric equations

$$\begin{cases} x = x_0 + r(x_1 - x_0) + s(x_2 - x_0) \\ y = y_0 + r(y_1 - y_0) + s(y_2 - y_0) \\ z = z_0 + r(z_1 - z_0) + s(z_2 - z_0) \end{cases}$$

Cartesian equation is obtained by finding the following determinant.

$$\begin{vmatrix} x - x_0 & x_1 - x_0 & x_2 - x_0 \\ y - y_0 & y_1 - y_0 & y_2 - y_0 \\ z - z_0 & z_1 - z_0 & z_2 - z_0 \end{vmatrix} = 0$$

Or we can use the determinant

$$\begin{vmatrix} x & x_0 & x_1 & x_2 \\ y & y_0 & y_1 & y_2 \\ z & z_0 & z_1 & z_2 \\ 1 & 1 & 1 & 1 \end{vmatrix} = 0$$

We can also find the Cartesian equation by finding the value of two parameters in first two equation of parametric equations and put them in the third equation.

16. The Cartesian equation of a plane has the form

$ax + by + cz + d = 0$ with $(a, b, c) \neq (0, 0, 0)$ or we can write it as $ax + by + cz = k$. This equation is also called the scalar equation of the plane.

17. Consider four points

(a_1, a_2, a_3) ; (b_1, b_2, b_3) ; (c_1, c_2, c_3) and (d_1, d_2, d_3) . These points are coplanar (meaning that they lie on the same plane) if the following condition is satisfied:

$$\begin{vmatrix} a_1 & b_1 & c_1 & d_1 \\ a_2 & b_2 & c_2 & d_2 \\ a_3 & b_3 & c_3 & d_3 \\ 1 & 1 & 1 & 1 \end{vmatrix} = 0 \text{ or } \begin{vmatrix} a_1 - d_1 & b_1 - d_1 & c_1 - d_1 \\ a_2 - d_2 & b_2 - d_2 & c_2 - d_2 \\ a_3 - d_3 & b_3 - d_3 & c_3 - d_3 \end{vmatrix} = 0$$

18. A line L is then perpendicular to plane α if and only if each direction vector of L is perpendicular to each direction vector of α .

19. The Cartesian equation of plane passing through the point (a_1, a_2, a_3) with orthogonal vector (a, b, c) is $a(x - a_1) + b(y - a_2) + c(z - a_3) = 0$.

20. A line and a plane are parallel if the direction vector of the line is perpendicular to the normal vector of the plane.

21. Two planes are perpendicular if their normal vectors are perpendicular.

22. Two planes are parallel if their normal vectors are parallel.

23. The distance between point $B(b_1, b_2, b_3)$ and plane $\alpha \equiv ax + by + cz = d$ is given by

$$d(B, \alpha) = \frac{|ab_1 + bb_2 + cb_3 - d|}{\sqrt{a^2 + b^2 + c^2}}.$$

24. When calculating the distance between two planes, first check if the planes are parallel. If they are not, they intersect and the distance is zero. If they are parallel, find a point in one of the planes and calculate its distance to the other plane.
25. When calculating the distance between a line and a plane, first check if the line is parallel to the plane. If not, they intersect and the distance is zero. If they are parallel, find a point on the line and calculate its distance to the plane.
26. To find the projection of the line AB on the plane α , we need a plane β containing the given line AB and perpendicular to the given plane α . The equation of the plane β and the plane α taken together are the equations of the projection.
27. When finding the image of a point P with respect to the plane α , we need to find the line, say L, through point P and perpendicular to the plane α . Then next is to find the intersection of line L and plane α , say N. Now, if Q is the image of P, the point N is the midpoint of PQ. From this, we can find the coordinate of Q.
28. When we need the image of a line, we will need the parametric form of any point on the line and then find its image using the same method. The image will be in parametric form. Now, replacing the parameter by any two chosen values in the obtained image, we will get two points. From these two points, we can find the equations of the line which will be the image of the given line.
29. The intersection of a line and a plane can be an empty set, a point, or that line.
30. Consider two planes
- $$\alpha \equiv a_1x + b_1y + c_1z = d_1$$
- $$\beta \equiv a_2x + b_2y + c_2z = d_2$$

The intersection of these planes is defined to be all points (x, y, z) verifying the two equations at the same time. So, we need $S = \alpha \cap \beta$.

31. The angle which line L makes with plane α is defined to be the angle

$$\theta = \arcsin \left(\frac{\vec{n} \cdot \vec{u}}{\|\vec{n}\| \cdot \|\vec{u}\|} \right)$$

\vec{n} is the normal vector of the plane, \vec{u} is the direction vector of line.

32. The angle between the planes is the same as the acute angle between their two normal vectors (sliding their tails together if necessary).

33. The equation of a sphere of centre (k, l, m) and radius r is given by
 $S \equiv (x-k)^2 + (y-l)^2 + (z-m)^2 = r^2$

34. The general equation of a sphere:

$$S \equiv x^2 + y^2 + z^2 + ax + by + cz + d = 0$$

In this case, the centre is given by $\Omega = \left(-\frac{a}{2}, -\frac{b}{2}, -\frac{c}{2} \right)$ and

the radius is given by $r = \frac{1}{2} \sqrt{a^2 + b^2 + c^2 - 4d}$.

35. If the line passes through the centre of a sphere, there are two points of intersection and those points are called **antipodal** points.

We are interested in the case where the line-plane intersection is a point.

In this case, the line is tangent to the sphere and there is one point of intersection. At this point, there are many lines tangent to the sphere and they are included in the plane tangent to the sphere at this point.

36. Consider a sphere $S \equiv x^2 + y^2 + z^2 + ax + by + cz + d = 0$ with centre $\Omega = (k, l, m)$ and radius r and plane $\alpha \equiv hx + ny + pz = q$. If $d(\Omega, \alpha) < r$, the plane cuts the sphere and the intersection is a circle whose centre is on the plane

If $d(\Omega, \alpha) = r$, the plane is tangent to the sphere and the intersection is the point which lies on the perpendicular line of the plane passing through the centre of the sphere and it is the intersection between this perpendicular line and the plane.

If $d(\Omega, \alpha) > r$, there is no intersection.

37. Consider two spheres with centers C_1 and C_2 ; radii r_1 and r_2 . The position of these two spheres depends on the distance between their centers, $d(\Omega_1, \Omega_2)$

- ⊙ If $d > r_1 + r_2$. Two spheres are exterior and hence no intersection.
- ⊙ If $d < r_1 + r_2$. Two spheres are interior and hence no intersection.
- ⊙ If $d = r_1 + r_2$. Two spheres are tangent exterior and hence there is a point of intersection.
- ⊙ If $d = |r_1 - r_2|$. Two spheres are tangent interior and hence there is a point of intersection.
- ⊙ If $|r_1 - r_2| < d < r_1 + r_2$. One sphere cuts another. The intersection is a circle.

End of Unit Assessment

- Find in terms of \vec{A} and \vec{B} the position vector of the point P which divides the line segment $[AB]$:
 - internally in the ratio 2:1,
 - internally in the ratio 4:3,
 - internally in the ratio 2:3,
 - externally in the ratio 1:3,
 - externally in the ratio 5:2,
 - externally in the ratio 3:4.
- The vertices A, B and C of the parallelogram ABCD have position vectors \vec{a} , \vec{b} and \vec{c} respectively. If M is the midpoint of BC and BD meets AM at N, find in terms of \vec{a} , \vec{b} and/or \vec{c} the position vectors of M and N.
- State the vector equations of the line which is parallel to the vector $\vec{u} = 2\vec{i} + 3\vec{j} - \vec{k}$ and which passes through the point $A(1,1,1)$.
- State the vector equation of the line which passes through the point $A(-1,2,1)$ and which is parallel to the vector $\vec{u} = (1,2,3)$.
- Show that the point with position vector $4\vec{i} - \vec{j} + 12\vec{k}$ lies on the line with vector equation $x\vec{i} + y\vec{j} + z\vec{k} = 2\vec{i} + 3\vec{j} + 4\vec{k} + r(\vec{i} - 2\vec{j} + 4\vec{k})$
- If the point $A(a,b,3)$, lies on the line $L \equiv \begin{cases} x = 2 + r \\ y = 4 + r \\ z = -1 + r \end{cases}$
Find the value of a and b .
- Given points $A(2,-1,1)$ and $B(5,2,-2)$. Find
 - \vec{AB}
 - the vector equation of the line that passes through A and B.

8. Find the Cartesian equations of the line with vector equations

a) $(x, y, z) = (2, 3, -1) + r(2, 3, 1)$

b) $(x, y, z) = (3, -1, 2) + r(3, 2, -4)$

c) $(x, y, z) = (2, 1, 1) + r(2, -1, -1)$

9. Find the vector equation of the line with parametric equations

$$\begin{cases} x = 2 + 3r \\ y = 5 - 2r \\ z = 4 - r \end{cases}$$

10. Find the vector equations of the lines with the following symmetric equations

a) $\frac{x-2}{3} = \frac{y-2}{2} = \frac{z+1}{4}$ b) $x-3 = \frac{y+2}{4} = \frac{z-3}{-1}$

11. State a vector that is parallel to the line with vector equation $(x, y, z) = (3, 4, 1) + r(2, 5, 3)$

12. Find the vector, symmetric and parametric equations of the line passing through $P(1, 0, -3)$ and parallel to the line with parametric equations

$$\begin{cases} x = -1 + 2t \\ y = 2 - t \\ z = 3 + 3t \end{cases}$$

13. Write down the vector equation of the plane passing through the point A and parallel to the vectors \vec{p} and \vec{q} in each of the following:

a) $A(2, 3, 4)$, $\vec{p} = (2, -3, 2)$, $\vec{q} = (0, 1, 2)$

b) $A(0, 0, -2)$, $\vec{p} = (3, 3, -1)$, $\vec{q} = (1, -1, 1)$

c) $A(-2, -1, -3)$, $\vec{p} = (1, 0, 1)$, $\vec{q} = (2, 1, 1)$

d) $A(5, 1, -4)$, $\vec{p} = (1, -1, 1)$, $\vec{q} = (3, -1, -1)$

14. In each of the following, find an equation of the plane determined by the data:

- a) Through the point $A(2,3,-4)$ and perpendicular to $\vec{v} = (2,3,-4)$.
- b) Through the points $A(6,0,0)$, $B(0,0,-3)$ and $C(3,6,0)$.
- c) Through the points $(5,2,-7)$, $(-2,4,-2)$ and the origin.
- d) Through the points $A(1,1,-1)$ and containing the vectors $\vec{u} = (2,1,2)$ and $\vec{v} = (0,5,4)$.
- e) Through the points $(3,2,-1)$, $(4,4,0)$ and perpendicular to the plane $2x + 4y - 4z = 3$
- f) Through the points $(2,-1,-3)$, $(4,-3,2)$ and parallel to the x -axis.
- g) Through the point $(3,4,2)$ and perpendicular to the x -axis.
15. Find the equation of the plane which is parallel to the plane $x + 5y - 4z + 22 = 0$ and whose sum of intercepts on the coordinates axes is 19.
16. Obtain the equation of the plane passing through the point $(-2,-2,2)$ and containing the line joining the points $(1,1,1)$ and $(1,-1,2)$.
17. Find the equation of the plane through the point $(2,3,4)$ and parallel to the plane $5x - 6y + 7z = 3$.
18. Find the Cartesian equation of the plane with parametric equations
- $$\begin{cases} x = 3 + 2r + s \\ y = -r + s \\ z = 1 + s \end{cases}$$
19. The plane has vector equation
- $$\begin{pmatrix} x \\ y \\ z \end{pmatrix} = \begin{pmatrix} 4 \\ 3 \\ 2 \end{pmatrix} + r \begin{pmatrix} 1 \\ -1 \\ -1 \end{pmatrix} + s \begin{pmatrix} 2 \\ 3 \\ 1 \end{pmatrix}$$
- Show that the point with position vector $\begin{pmatrix} 7 \\ -5 \\ -4 \end{pmatrix}$ lies on this plane.

20. Find the equations to the two planes through the points $(0, 4, -3)$ and $(6, -4, 3)$, other than the plane; through the origin which cuts off from the axes intercepts whose sum is zero.
21. Write down the vector equation of the plane passing through the point $A(1, 0, -2)$ and containing the vectors $\vec{i} + \vec{j}$ and \vec{k} .
22. Find the shortest distance from the origin to each of the following lines:
- $x = 1 + t, y = 2 + t, z = 3 + t$,
 - $x = 2t, y = 3 - t, z = 3 - 2t$
 - $x = t + 4, y = 2t + 2, z = 3t + 2$
 - $x = 3t - 1, y = 2t + 1, z = t - 6$
23. Find the shortest distance from point P to the given line and the coordinates of the point on the line closest to P in each of the following:
- $P(3, 5, 9), x\vec{i} + y\vec{j} + z\vec{k} = \vec{i} + (6 + 2r)\vec{j} + (1 - r)\vec{k}$
 - $P(6, 1, 1), x\vec{i} + y\vec{j} + z\vec{k} = r\vec{i} + (2r - 5)\vec{j} + (7 - 4r)\vec{k}$
 - $P(8, -2, 4), x\vec{i} + y\vec{j} + z\vec{k} = (8 + 2r)\vec{i} + (4 + 2r)\vec{j} - (2 + r)\vec{k}$
 - $P(3, 1, 2), x\vec{i} + y\vec{j} + z\vec{k} = (1 + r)\vec{i} + (2 - r)\vec{j} + (3 + r)\vec{k}$
24. Find the shortest distance between the lines $\frac{x-8}{3} = \frac{y+9}{-16} = \frac{z-10}{7}$ and $\frac{x-15}{3} = \frac{y-29}{8} = \frac{z-5}{-5}$.
25. Calculate the angle between the lines $A \equiv \begin{cases} 4x - 5y + 8z = 23 \\ x + 7y - 3z = 10 \end{cases}$ and $B \equiv \begin{cases} 6x + 5y + z = 8 \\ 2x + 2y - 3z = 124 \end{cases}$
26. Calculate the angle between the line $D \equiv \begin{cases} x + 4y - z = 10 \\ 2x - 3y + 5z = 8 \end{cases}$ and the plane $\alpha \equiv 3x + 6y - 8z = 21$.
27. Calculate the angle between the planes $2x + 3y + z = 10$ and $x - 2y - 3z + 12 = 0$.

28. Find the angle between the skew lines

$$L_1 : \begin{cases} x = -2 + 2t \\ y = 3 - t \\ z = -1 + 3t \end{cases} \quad \text{and} \quad L_2 : \begin{cases} x = 3 - t \\ y = -2 + 4t \\ z = 1 - 2t \end{cases}$$

29. Find the angle between the line

$$\frac{x+1}{2} = \frac{y}{3} = \frac{z-3}{6} \quad \text{and the plane } 3x + y + z = 7.$$

30. Find the angle between the line

$$D \equiv \begin{cases} 3x - 7y - 5z = 1 \\ 5x - 13y + 3z + 2 = 0 \end{cases}$$

and the plane

$$\alpha \equiv 8x - 11y + 2z = 0.$$

31. Find the centres and radii of spheres

a) $x^2 + y^2 + z^2 - 6x + 8y - 10z + 1 = 0$

b) $x^2 + y^2 + z^2 - 2x - 4y - 6z + 5 = 0$

c) $2x^2 + 2y^2 + 2z^2 - 2x + 4y + 2z + 1 = 0$

32. Find the equation of the sphere whose

a) Centre $(1, 2, 3)$, radius 2

b) Centre $(2, 0, 2)$, radius 2

c) Centre $(2, 3, 0)$, radius 6

33. If $x^2 + y^2 + z^2 - 2x - 6y - 2z + d = 0$ is the equation of a sphere with the points $(-1, 0, 2)$ and $(3, 6, 0)$ as extremities of one of its diametre, find the value of d .

34. Find the equation to the sphere through the points

$$(0, 0, 0), (0, 1, -1), (-1, 2, 0), (1, 2, 3).$$

35. Find the equation of the sphere through four points

$$(4, -1, 2), (0, -2, 3), (1, -5, -1), (2, 0, 1).$$

36. Find the equation of the sphere which passes through the points $(1, 0, 0)$, $(0, 1, 0)$ and $(0, 0, 1)$ and which has radius

$$\sqrt{\frac{2}{3}}.$$

37. Obtain the sphere having its centre on the line $5y + 2z = 0 = 2x - 3y$ and passing through the two points $(0, -2, -4), (2, -1, -1)$
38. Find the equation of the sphere on the join of $(1, 2, 3)$ and $(0, 4, -1)$ as diameter.
39. Find the equation of the sphere through the circle $x^2 + y^2 + z^2 = 1, x + y + z + 2 = 0$ and the point $(1, 1, 1)$. Locate its centre and find its radius.
40. Find the equation of the sphere through the circle $x^2 + y^2 + z^2 + 2x + 3y + 6 = 0, x - 2y + 4z - 9 = 0$ and the centre of the sphere $x^2 + y^2 + z^2 - 2x + 4y - 6z + 5 = 0$.
41. Obtain the equation of the sphere having the circle $x^2 + y^2 + z^2 + 10y - 4z - 8 = 0, x + y + z = 3$ as a great circle.
42. A sphere S has points $(0, 1, 0), (3, -5, 2)$ at opposite ends of a diameter. Find the equation of the sphere having the intersection of S with plane $5x - 2y + 4z + 7 = 0$ as a great circle.
43. Obtain the equation of the sphere which passes through the circle $x^2 + y^2 = 4, z = 0$ and is cut by the plane $x + 2y + 2z = 0$ in a circle of radius 3.
44. Find the equation of the tangent plane to the sphere $3(x^2 + y^2 + z^2) - 2x - 3y - 4z - 22 = 0$ at the point $(1, 3, 5)$.
45. Find the value of a for which the plane $2x + 2y + z = a$ touches the sphere $x^2 + y^2 + z^2 - 2x - 2y - 2z - 6 = 0$.
46. Find the coordinates of the point on the sphere $x^2 + y^2 + z^2 - 4x + 2y = 4$ the tangent planes at which are parallel to the plane $2x - y + 2z = 1$.
47. Find the equation of the sphere which has its centre at the origin and which touches the line $2(x+1) = 2 - y = z + 3$
48. The plane $\frac{x}{2} + \frac{y}{3} + \frac{z}{4} = 1$ cuts the axes in the points A, B, C . Find the area of the surface ABC . Draw a sketch.
49. A plane makes intercepts $0A = a, 0B = b, 0C = c$ on the axes. Find the area of triangle ABC .

Unit 9

Bivariate Statistics

Introductory activity

In Kabeza village, after her 9 observations about farming, UMULISA saw that in every house observed, where there are a number x of cows there also y domestic ducks, and then she got the following results of (x,y) pairs:

$(1,4), (2,8), (3,4), (4,12), (5,10)$
 $(6,14), (7,16), (8,6), (9,18)$

- Represent this information graphically in (x,y) - coordinates.
- Chose two points, find the equation of a line joining them and draw it in the same graph. How are the positions of remaining points vis-a-vis this line?
- According to your observation from (a), explain in your own words if there is any relationship between the variation of the number x of cows and the number y of domestic ducks.



Objectives

By the end of this unit, a student will be able to:

- ⊙ Find measures of central tendency in two quantitative variables.
- ⊙ Find measures of variability in two quantitative variables.
- ⊙ Determine the linear regression line of a given series.
- ⊙ Calculate a linear correlation coefficient of a given double series and interpret it.

9.1. Covariance



Activity 9.1

Complete the following table

i	x_i	y_i	$x_i - \bar{x}$	$y_i - \bar{y}$	$(x_i - \bar{x})(y_i - \bar{y})$
1	3	6			
2	5	9			
3	7	12			
4	3	10			
5	2	7			
6	6	8			
	$\sum_{i=1}^6 x_i = \dots$	$\sum_{i=1}^6 y_i = \dots$			$\sum_{i=1}^6 (x_i - \bar{x})(y_i - \bar{y}) = \dots$
	$\bar{x} = \dots$	$\bar{y} = \dots$			

What can you get from the following expressions:

$$1. \sum_{i=1}^k (x_i - \bar{x})(x_i - \bar{x}) \qquad 2. \sum_{i=1}^k (x_i - \bar{x})(y_i - \bar{y})$$

In case of two variables, say x and y , there is another important result called **covariance of x and y** , denoted $\text{cov}(x, y)$.

The **covariance of variables x and y** is a measure of how these two variables change together. If the greater values of one variable mainly correspond with the greater values of the other variable, and the same holds for the smaller values, i.e. the variables tend to show similar behavior, the covariance is positive. In the opposite case, when the greater values of one variable mainly correspond to the smaller values of the other, i.e. the variables tend to show opposite behavior, the covariance is negative. If covariance is zero, the variables are said to be **uncorrelated**, meaning that there is no linear relationship between them.

Therefore, the sign of covariance shows the tendency in the linear relationship between the variables. The magnitude of covariance is not easy to interpret.

Covariance of variables x and y , where the summation of frequencies $\sum_k f_i = n$ are equal for both variables, is defined to be

$$\text{cov}(x, y) = \frac{1}{n} \sum_{i=1}^k f_i (x_i - \bar{x})(y_i - \bar{y})$$

Developing this formula, we have

$$\begin{aligned} \text{cov}(x, y) &= \frac{1}{n} \sum_{i=1}^k f_i (x_i y_i - x_i \bar{y} - \bar{x} y_i + \bar{x} \bar{y}) \\ &= \frac{1}{n} \sum_{i=1}^k f_i x_i y_i - \frac{1}{n} \sum_{i=1}^k f_i x_i \bar{y} - \frac{1}{n} \sum_{i=1}^k f_i \bar{x} y_i + \frac{1}{n} \sum_{i=1}^k f_i \bar{x} \bar{y} \\ &= \frac{1}{n} \sum_{i=1}^k f_i x_i y_i - \frac{1}{n} \bar{y} \sum_{i=1}^k f_i x_i - \frac{1}{n} \bar{x} \sum_{i=1}^k f_i y_i + \bar{x} \bar{y} \frac{1}{n} \sum_{i=1}^k f_i \quad \left[\frac{1}{n} \sum_{i=1}^k f_i = \frac{1}{n} \times n = 1 \right] \\ &= \frac{1}{n} \sum_{i=1}^k f_i x_i y_i - \bar{x} \bar{y} - \bar{x} \bar{y} + \bar{x} \bar{y} \\ &= \frac{1}{n} \sum_{i=1}^k f_i x_i y_i - \bar{x} \bar{y} \end{aligned}$$

Thus, the covariance is also given by

$$\text{cov}(x, y) = \frac{1}{n} \sum_{i=1}^k f_i x_i y_i - \bar{x} \bar{y}$$

Example 9.1

Find the covariance of x and y in the following data sets

x	3	5	6	8	9	11
y	2	3	4	6	5	8

Solution

We have

x_i	y_i	$x_i - \bar{x}$	$y_i - \bar{y}$	$(x_i - \bar{x})(y_i - \bar{y})$
	2	-4	-2.6	10.4
	3	-2	-1.6	3.2
	4	-1	-0.6	0.6
	6	1	1.4	1.4
	5	2	0.4	0.8
11	8	4	3.4	13.6
$\sum_{i=1}^6 x_i = 42$	$\sum_{i=1}^6 y_i = 28$			$\sum_{i=1}^6 (x_i - \bar{x})(y_i - \bar{y}) = 30$
$\bar{x} = 7$	$\bar{y} = 4.6$			

Thus,

$$\begin{aligned} \text{cov}(x, y) &= \frac{1}{6} \sum_{i=1}^6 f_i (x_i - \bar{x})(y_i - \bar{y}) \\ &= \frac{1}{6}(30) \\ &= 5 \end{aligned}$$

Example 9.2

Find the covariance of the following distribution

$x \backslash y$	0	2	4
1	2	1	3
2	1	4	2
3	2	5	0

Solution

Convert the double entry into a simple table and compute the arithmetic means

x_i	y_i	f_i	$x_i f_i$	$y_i f_i$	$x_i y_i f_i$
0	1	2	0	2	0
0	2	1	0	2	0
0	3	2	0	6	0
2	1	1	2	2	2
2	2	4	8	8	16
2	3	5	10	15	30
4	1	3	12	3	12
4	2	2	8	4	16
4	3	0	0	0	0
		$\sum_{i=1}^9 f_i = 20$	$\sum_{i=1}^9 x_i f_i = 40$	$\sum_{i=1}^9 y_i f_i = 41$	$\sum_{i=1}^9 x_i y_i f_i = 76$

$$\bar{x} = \frac{40}{20} = 2, \quad \bar{y} = \frac{41}{20} = 2.05$$

$$\text{cov}(x, y) = \frac{76}{20} - 2 \times 2.05 = -0.3$$

Alternative method

$$\text{cov}(x, y) = \frac{1}{n} \sum_{i=1}^k f_i x_i y_i - \bar{x} \bar{y} \quad \bar{x} = \frac{1}{n} \sum_{i=1}^k x_i f_i, \quad \bar{y} = \frac{1}{n} \sum_{i=1}^k y_i f_i$$

$y \backslash x$	0	2	4	Total
1	2	1	3	6
2	1	4	2	7
3	2	5	0	7
Total	5	10	5	20

$$\begin{aligned} \bar{x} &= \frac{1}{20} (0 \times 5 + 2 \times 10 + 4 \times 5) \\ &= \frac{40}{20} = 2 \end{aligned}$$

$$\begin{aligned}\bar{y} &= \frac{1}{20}(1 \times 6 + 2 \times 7 + 3 \times 7) \\ &= \frac{41}{20} = 2.05 \\ \text{cov}(x, y) &= \frac{1}{20} \left(0 \times 1 \times 2 + 0 \times 2 \times 1 + 0 \times 3 \times 2 + 2 \times 1 \times 1 + 2 \times 2 \times 4 \right. \\ &\quad \left. + 2 \times 3 \times 5 + 4 \times 1 \times 3 + 4 \times 2 \times 2 + 4 \times 3 \times 0 \right) - 2 \times 2.05 \\ &= \frac{1}{20} (0 + 0 + 0 + 2 + 16 + 30 + 12 + 16 + 0) - 4.1 \\ &= \frac{76}{20} - 4.1 \\ &= -0.3\end{aligned}$$

Application Activity 9.1

1. The scores of 12 students in their mathematics and physics classes are

Mathematics	2	3	4	4	5	6	6	7	7	8	10	10
Physics	1	3	2	4	4	4	6	4	6	7	9	10

Find the covariance of the distribution.

2. The values of two variables x and y are distributed according to the following table

$y \backslash x$	100	50	25
14	1	1	0
18	2	3	0
22	0	1	2

Calculate the covariance

9.2. Regression lines

We use the regression line to **predict** a value of y for any given value of x and vice versa. The “best” line would make the best predictions: the observed y -values should stray as little as possible from the line. This straight line is the regression line from which we can adjust its algebraic expressions and it is written as $y = ax + b$.

Activity 9.2



The regression line y on x has the form $y = ax + b$. We need the distance from this line to each point of the given data to be small, so that the sum of the square of such distances be very small. That is $D = \sum_{i=1}^k [y_i - (ax_i + b)]^2$ or $D = \sum_{i=1}^k (y_i - ax_i - b)^2$ (1) is minimum.

1. Differentiate relation (1) with respect to b . In this case, y , x and a will be considered as constants.
2. Equate relation obtained in 1) to zero, divide each side by n and give the value of b .
3. Take the value of b obtained in 2) and put it in relation obtained in 1). Differentiate the obtained relation with respect to a , equate it to zero and divide both sides by n to find the value of a .
4. Using the relations: The variance for variable x is

$$\sigma_x^2 = \frac{1}{n} \sum_{i=1}^k (x_i - \bar{x})^2 \text{ and the variance for variable } y \text{ is}$$

$$\sigma_y^2 = \frac{1}{n} \sum_{i=1}^k (y_i - \bar{y})^2 \text{ and the covariance of these two variables is}$$

$$\text{cov}(x, y) = \frac{1}{n} \sum_{i=1}^k (x_i - \bar{x})(y_i - \bar{y}), \text{ give the}$$

simplified expression equal to a .

5. Put the value of b obtained in 2) and the value of a obtained in 4) in relation $y = ax + b$ and give the expression of regression line y on x .

From Activity 9.2, the regression line y on x is written as

$$y = \frac{\text{cov}(x, y)}{\sigma_x^2} x + \left(\bar{y} - \frac{\text{cov}(x, y)}{\sigma_x^2} \bar{x} \right)$$

We may write

$$L_{y/x} \equiv y - \bar{y} = \frac{\text{cov}(x, y)}{\sigma_x^2} (x - \bar{x})$$

Note that the regression line x on y is $x = cy + d$ given by

$$x - \bar{x} = \frac{\text{cov}(x, y)}{\sigma_y^2} (y - \bar{y})$$

This line is written as

$$L_{x/y} \equiv x - \bar{x} = \frac{\text{cov}(x, y)}{\sigma_y^2} (y - \bar{y})$$

Short cut method of finding regression line

To abbreviate the calculations, the two regression lines can be determined as follows:

a) Relation y in function of X is $L_{y/x} \equiv y = ax + b$ and the values of a and b are found by solving the simultaneous equations:

$$\begin{cases} \sum_{i=1}^k f_i y_i = a \sum_{i=1}^k f_i x_i + b n \\ \sum_{i=1}^k f_i x_i y_i = a \sum_{i=1}^k f_i x_i^2 + b \sum_{i=1}^k f_i x_i \end{cases}$$

These equations are called the normal equations for y on x .

b) Relation x in function is $L_{x/y} \equiv x = cy + d$ and the values of c and d are found by solving the simultaneous equations:

$$\begin{cases} \sum_{i=1}^k f_i x_i = c \sum_{i=1}^k f_i y_i + d n \\ \sum_{i=1}^k f_i x_i y_i = c \sum_{i=1}^k f_i y_i^2 + d \sum_{i=1}^k f_i y_i \end{cases}$$

These equations are called the normal equations for x on y .

Example 9.3

Find the regression line of y on x for the following data and estimate the value of y for $x = 4, x = 7, x = 16$ and the value of x for $y = 7, y = 9, y = 16$.

x	3	5	6	8	9	11
y	2	3	4	6	5	8

Solution

x	y	$x - \bar{x}$	$y - \bar{y}$	$(x - \bar{x})^2$	$(y - \bar{y})^2$	$(x - \bar{x})(y - \bar{y})$
3	2	-4	-2.6	16	6.76	10.4
5	3	-2	-1.6	4	2.56	3.2
6	4	-1	-0.6	1	0.36	0.6
8	6	1	1.4	1	1.96	1.4
9	5	2	0.4	4	0.16	0.8
11	8	4	3.4	16	11.56	13.6
$\sum_{i=1}^6 x_i = 42$	$\sum_{i=1}^6 y_i = 28$			$\sum_{i=1}^6 (x_i - \bar{x})^2 = 42$	$\sum_{i=1}^6 (y_i - \bar{y})^2 = 23.36$	$\sum_{i=1}^6 (x_i - \bar{x})(y_i - \bar{y}) = 30$

$$\bar{x} = \frac{42}{6} = 7, \quad \bar{y} = \frac{28}{6} = 4.7$$

$$\text{cov}(x, y) = \frac{1}{n} \sum_{i=1}^k (x_i - \bar{x})(y_i - \bar{y}) = \frac{30}{6} = 5$$

$$\sigma_x^2 = \frac{42}{6} = 7, \quad \sigma_y^2 = \frac{23.36}{6} = 3.89$$

$$L_{y/x} \equiv y - \bar{y} = \frac{\text{cov}(x, y)}{\sigma_x^2} (x - \bar{x})$$

$$L_{y/x} \equiv y - 4.7 = \frac{5}{7} (x - 7)$$

Finally, the line of y on x is

$$L_{y/x} \equiv y = \frac{5}{7}x - 0.3$$

And

$$L_{x/y} \equiv x - \bar{x} = \frac{\text{cov}(x, y)}{\sigma_y^2} (y - \bar{y})$$

$$L_{x/y} \equiv x - 7 = \frac{5}{3.89} (y - 4.7)$$

Finally, the line of x on y is

$$L_{x/y} \equiv y = 1.3x + 1$$

Alternative method

x	y	x^2	y^2	xy
3	2	9	4	6
5	3	25	9	15
6	4	36	16	24
8	6	64	36	48
9	5	81	25	45
11	8	121	64	88
$\sum_{i=1}^6 x_i = 42$	$\sum_{i=1}^6 y_i = 28$	$\sum_{i=1}^6 x_i^2 = 336$	$\sum_{i=1}^6 y_i^2 = 154$	$\sum_{i=1}^6 x_i y_i = 226$

$$L_{y/x} \equiv y = ax + b$$

$$\begin{cases} \sum_{i=1}^k f_i y_i = a \sum_{i=1}^k f_i x_i + b n \\ \sum_{i=1}^k f_i x_i y_i = a \sum_{i=1}^k f_i x_i^2 + b \sum_{i=1}^k f_i x_i \end{cases}$$

$$\begin{cases} 28 = 42a + 6b \\ 226 = 336a + 42b \end{cases} \Leftrightarrow \begin{cases} a = \frac{5}{7} \\ b = -0.3 \end{cases}$$

Thus, the line of y on x is

$$L_{y/x} \equiv y = \frac{5}{7}x - 0.3$$

If

$$x = 4 \Rightarrow y = 2.5$$

$$x = 7 \Rightarrow y = 4.7$$

$$x = 16 \Rightarrow y = 11.1$$

$$L_{x/y} \equiv x = cy + d$$

$$\begin{cases} \sum_{i=1}^k f_i x_i = c \sum_{i=1}^k f_i y_i + d n \\ \sum_{i=1}^k f_i x_i y_i = c \sum_{i=1}^k f_i y_i^2 + d \sum_{i=1}^k f_i y_i \end{cases}$$

$$\begin{cases} 42 = 28c + 6d \\ 226 = 154c + 28d \end{cases} \Leftrightarrow \begin{cases} c = 1.3 \\ d = 1 \end{cases}$$

Thus, the line of x on y is $L_{x/y} \equiv x = 1.3y + 1$

If

$$y = 7 \Rightarrow x = 10.1$$

$$y = 9 \Rightarrow x = 12.7$$

$$y = 16 \Rightarrow x = 21.8$$

Application Activity 9.2

1. Consider the following table:

x	y
60	3.1
61	3.6
62	3.8
63	4
65	4.1

a) Find the regression line of y on x

b) Calculate the approximate y value for the variable $x = 64$.

2. The values of two variables x and y are distributed according to the following table.

$y \backslash x$	100	50	25
14	1	1	0
18	2	3	0
22	0	1	2

Find the regression lines.

9.3. Coefficient of correlation

Pearson's coefficient of correlation (or product moment coefficient of correlation)



Activity 9.3

Consider the following table:

x	3	5	7	3	2	6
y	6	9	12	10	7	8

1. Find the standard deviations σ_x, σ_y
2. Find covariance $\text{cov}(x, y)$
3. Calculate the ratio $\frac{\text{cov}(x, y)}{\sigma_x \sigma_y}$.

The **Pearson's coefficient of correlation** (or **product moment coefficient of correlation** or simply **coefficient of correlation**), denoted by r , is a measure of the strength of linear relationship between two variables.

The coefficient of correlation between two variables x and y is given by

$$r = \frac{\text{cov}(x, y)}{\sigma_x \sigma_y}$$

Where,

$\text{cov}(x, y)$ is covariance of x and y

σ_x is the standard deviation for x

σ_y is the standard deviation for y

Properties of the coefficient of correlation

- a) The coefficient of correlation does not change the measurement scale. That is, if the height is expressed in metres or feet, the coefficient of correlation does not change.
- b) The sign of the coefficient of correlation is the same as the covariance.
- c) The square of the coefficient of correlation is equal to the product of angular coefficients (slopes) of two regression lines.

In fact, $r = \frac{\text{cov}(x, y)}{\sigma_x \sigma_y}$. Squaring both sides gives

$$\begin{aligned} r^2 &= \left[\frac{\text{cov}(x, y)}{\sigma_x \sigma_y} \right]^2 \\ &= \frac{\text{cov}^2(x, y)}{\sigma_x^2 \sigma_y^2} = \frac{\text{cov}(x, y)}{\sigma_x^2} \times \frac{\text{cov}(x, y)}{\sigma_y^2} \end{aligned}$$

- d) If the coefficient of correlation is known, it can be used to find the angular coefficients of two regression lines.

We know that the angular coefficient of the regression line y on x is $\frac{\text{cov}(x, y)}{\sigma_x^2}$. From this, we have; $\frac{\text{cov}(x, y)}{\sigma_x^2} = \frac{\text{cov}(x, y)}{\sigma_x \sigma_x} \times \frac{\sigma_y}{\sigma_y}$
 $= \frac{\text{cov}(x, y)}{\sigma_x \sigma_y} \times \frac{\sigma_y}{\sigma_x} = r \frac{\sigma_y}{\sigma_x}$

We know that the angular coefficient of the regression line x on y is $\frac{\text{cov}(x, y)}{\sigma_y^2}$. From this, we have; $\frac{\text{cov}(x, y)}{\sigma_y^2} = \frac{\text{cov}(x, y)}{\sigma_y \sigma_y} \times \frac{\sigma_x}{\sigma_x}$
 $= \frac{\text{cov}(x, y)}{\sigma_x \sigma_y} \times \frac{\sigma_x}{\sigma_y} = r \frac{\sigma_x}{\sigma_y}$

Thus, the angular coefficient of the regression line y on x is given by $r \frac{\sigma_y}{\sigma_x}$ and the angular coefficient of the regression line x on y is given by $r \frac{\sigma_x}{\sigma_y}$.

- e) Cauchy Inequality: $\text{cov}^2(x, y) \leq \sigma_x^2 \sigma_y^2$

In fact, $r = \frac{\text{cov}(x, y)}{\sigma_x \sigma_y} \Leftrightarrow \text{cov}(x, y) = r \sigma_x \sigma_y$.

Squaring both sides gives $\text{cov}^2(x, y) = r^2 \sigma_x^2 \sigma_y^2$

Or $\text{cov}^2(x, y) \leq \sigma_x^2 \sigma_y^2$

- f) The coefficient of correlation takes value ranging between -1 and +1. That is, $-1 \leq r \leq 1$

In fact, from Cauchy Inequality, we have,

$$\text{cov}^2(x, y) \leq \sigma_x^2 \sigma_y^2$$

$$\Leftrightarrow \frac{\text{cov}^2(x, y)}{\sigma_x^2 \sigma_y^2} \leq 1 \Leftrightarrow \left[\frac{\text{cov}(x, y)}{\sigma_x \sigma_y} \right]^2 \leq 1 \Leftrightarrow r^2 \leq 1$$

Taking square roots both sides

$$\Leftrightarrow \sqrt{r^2} \leq 1$$

$$\Leftrightarrow |r| \leq 1 \text{ since } \sqrt{x^2} = |x|$$

$$|r| \leq 1 \text{ is equivalent to } -1 \leq r \leq 1.$$

Thus, $-1 \leq r \leq 1$

- g) If the linear coefficient of correlation takes values closer to **-1**, the **correlation is strong and negative**, and will become stronger the closer r approaches -1 .
- h) If the linear coefficient of correlation takes values close to **1**, the **correlation is strong and positive**, and will become stronger the closer r approaches 1 .
- i) If the linear coefficient of correlation takes values close to **0**, the **correlation is weak**.
- j) If $r = 1$ or $r = -1$, there is **perfect correlation** and the line on the scatter plot is increasing or decreasing respectively.
- k) If $r = 0$, there is **no linear correlation**.

Example 9.4

Considering Example 9.3, we have seen that

$$\begin{aligned} \text{cov}(x, y) &= 5 \\ \sigma_x^2 &= \frac{42}{6} = 7, \quad \sigma_y^2 = \frac{23.36}{6} = 3.89 \end{aligned}$$

Then, the Pearson's coefficient of correlation is

$$r = \frac{\text{cov}(x, y)}{\sigma_x \sigma_y} = r = \frac{5}{\sqrt{7} \sqrt{3.89}} = \frac{5}{\sqrt{27.23}} = 0.96$$

Then, there is a very strong positive linear relationship between two variables.

We have also seen that the two regression lines are

$$L_{y/x} \equiv y = \frac{5}{7}x - 0.3$$

$$L_{x/y} \equiv x = 1.3y + 1$$

Their slopes are $\alpha = \frac{5}{7}$ and $\beta = 1.3$

We see that $r^2 = (0.96)^2 = 0.92$. On the other hand,

$$\alpha \cdot \beta = \frac{5}{7} \times 1.3 = 0.92.$$

Thus, $r^2 = \alpha \cdot \beta$

Example 9.5

A test is made over 200 families on number of children x and number of beds y per family. Results are collected in the table below:

$x \backslash y$	0	1	2	3	4	5	6	7	8	9	10
1	0	2	7	5	2	0	0	0	0	0	0
2	2	2	10	8	15	1	0	0	0	0	0
3	1	3	5	6	8	6	1	0	0	0	0
4	0	2	8	2	6	12	10	8	0	0	0
5	0	1	0	2	5	6	10	5	7	3	3
6	0	0	0	2	4	5	5	2	3	3	2

- What is the average number for children and beds per a family?
- Find the regression line of y on x .
- Can we confirm that there is a high linear correlation between the number of children and number of beds per family?

Solution

- Average number of children per family:

$$\bar{x} = \frac{1}{n} \sum_{i=1}^k f_i x_i, \quad \bar{y} = \frac{1}{n} \sum_{i=1}^k f_i y_i$$

$x \backslash y$	0	1	2	3	4	5	6	7	8	9	10	Total
1	0	2	7	5	2	0	0	0	0	0	0	16
2	2	2	10	8	15	1	0	0	0	0	0	38
3	1	3	5	6	8	6	1	0	0	0	0	30
4	0	2	8	2	6	12	10	8	0	0	0	48
5	0	1	0	2	5	6	10	5	7	3	3	42
6	0	0	0	2	4	5	5	2	3	3	2	26
Total	3	10	30	25	40	30	26	15	10	6	5	200

$$\begin{aligned}\bar{x} &= \frac{1}{200}(3 \times 0 + 10 \times 1 + 30 \times 2 + 25 \times 3 + 40 \times 4 + 30 \times 5 + 26 \times 6 + 15 \times 7 + 10 \times 8 + 6 \times 9 + 5 \times 10) \\ &= \frac{900}{200} = 4.5\end{aligned}$$

Or there are about 5 children per family.

Average number of beds per family:

$$\begin{aligned}\bar{y} &= \frac{1}{200}(16 \times 1 + 38 \times 2 + 30 \times 3 + 48 \times 4 + 42 \times 5 + 26 \times 6) \\ &= \frac{740}{200} = 3.7\end{aligned}$$

Or there are about 4 beds per family.

b) The equation of regression line of y on x is given by equation

$$y - \bar{y} = \frac{\text{cov}(x, y)}{\sigma_x^2} (x - \bar{x})$$

where $\bar{y} = 3.7$ and $\bar{x} = 4.5$

$$\begin{aligned}\sigma_x^2 &= \frac{1}{n} \sum_{i=1}^k x_i^2 f_i - (\bar{x})^2 \\ &= \frac{1}{200} \left(3 \times 0^2 + 10 \times 1^2 + 30 \times 2^2 + 25 \times 3^2 + 40 \times 4^2 + 30 \times 5^2 \right. \\ &\quad \left. + 26 \times 6^2 + 15 \times 7^2 + 10 \times 8^2 + 6 \times 9^2 + 5 \times 10^2 \right) - (4.5)^2 \\ &= \frac{5042}{200} - 20.25 \\ &= 4.96\end{aligned}$$

$$\begin{aligned}\text{cov}(x, y) &= \frac{1}{200} \sum_{i=1}^{66} f_i x_i y_i - \bar{x} \bar{y} \\ &= \frac{1}{200} \left(\begin{array}{l} 0 + 2 + 14 + 15 + 8 + 0 + 4 + 40 + 48 + 120 + 10 + 0 \\ + 9 + 30 + 54 + 96 + 90 + 18 + 0 + 8 + 64 + 24 + 96 \\ + 240 + 240 + 224 + 0 + 5 + 0 + 30 + 100 + 150 \\ + 300 + 175 + 280 + 135 + 150 + 0 + 36 + 96 + 150 \\ + 180 + 84 + 144 + 162 + 120 \end{array} \right) - 4.5 \times 3.7 \\ &= \frac{3751}{200} - 16.65 \\ &= 18.7555 - 16.65 \\ &= 2.105\end{aligned}$$

The required equation of regression of y on x is

$$y - 3.7 = \frac{2.105}{4.96}(x - 4.5)$$

Or

$$y = 0.4x + 1.8$$

c) Coefficient of correlation is given by $\frac{\text{cov}(x, y)}{\sigma_x \sigma_y}$

$$\begin{aligned}\sigma_y^2 &= \frac{1}{200} \sum_{i=1}^6 f_i y_i^2 - (\bar{y})^2 \\ &= \frac{1}{200} (16 + 38 \times 4 + 30 \times 9 + 48 \times 16 + 42 \times 25 + 26 \times 36) - (3.7)^2 \\ &= 15.96 - 13.69 \\ &= 2.27\end{aligned}$$

Therefore, the coefficient of correlation is

$$r = \frac{2.105}{\sqrt{4.96} \sqrt{2.27}} \approx 0.63$$

There is a high linear correlation.



Notice

Spearman's coefficient of rank correlation

A Spearman coefficient of rank correlation or Spearman's rho is a measure of statistical dependence between two variables. It assesses how well the relationship between two variables can be described using a monotonic function.

The **Spearman's coefficient of rank correlation** is denoted and defined by

$$\rho = 1 - \frac{6 \sum_{i=1}^k d_i^2}{n(n^2 - 1)}$$

Where, d refers to the difference of ranks between paired items in two series and n is the number of observations..

It is much easier to calculate the Spearman's coefficient of rank correlation than to calculate the Pearson's coefficient of correlation as there is far less working involved. However, in general, the Pearson's coefficient of correlation is a more accurate measure of correlation.

Method of ranking

Example 9.6

Suppose that we have the marks, x , of seven students in this order:
12, 18, 10, 13, 15, 16, 9

We assign the rank 1, 2, 3, 4, 5, 6, 7 such that the smallest value of x will be ranked 1.

That is

x	12	18	10	13	15	16	9
$Rank(x)$	3	7	2	4	5	6	1

If we have two or more equal values, we proceed as follows:

Consider the following series

x	66	65	66	67	66	64	68	68
-----	----	----	----	----	----	----	----	----

To assign the rank to this series, we do the following:

$x = 64$ will take rank 1, since it is the smallest value of x

$x = 65$ will be ranked 2.

$x = 66$ appears 3 times, since the previous value was ranked 2, here, 66 would be ranked 3, another 66 would be ranked 4 and another 5 but since there are three 66's, we need to find the average of those ranks which is $\frac{3+4+5}{3} = 4$ so that each 66 will be ranked 4.

$x = 67$ will be ranked 6 since we are on the 6th position

$x = 68$ appears 2 times, since the previous value was ranked 6, here, 68 would be ranked 7, and another 66 would be ranked 8 but since there are two 68's, we need to find the

average of those ranks which is $\frac{7+8}{2} = 7.5$ so that each 68 will be ranked 7.5

Thus we have the following:

x	66	65	66	67	66	64	68	68
$Rank(x)$	4	2	4	6	4	1	7.5	7.5

Example 9.7

Compute the Spearman's coefficient of rank correlation for the data given in Example 9.3

Solution

x	y	$Rank(x)$	$Rank(y)$	$Rank(x) - Rank(y) = d$	d^2
3	2	1	1	0	0
5	3	2	2	0	0
6	4	3	3	0	0
8	6	4	5	-1	1
9	5	5	4	1	2
11	8	6	6	0	0
					$\sum_{i=1}^6 d_i^2 = 3$

Then the Spearman's coefficient of correlation is

$$\begin{aligned}
 \rho &= 1 - \frac{\sum_{i=1}^6 d_i^2}{n(n^2 - 1)} \\
 &= 1 - \frac{6 \times 3}{6(36 - 1)} \\
 &= 1 - \frac{18}{210} \\
 &= 0.91
 \end{aligned}$$

Example 9.8

Calculate the Spearman's coefficient of rank correlation for the series.

x	12	8	16	12	7	10	12	16	12	9
y	6	5	7	7	4	6	8	13	10	10

Solution

x	y	$Rank(x)$	$Rank(y)$	$d_i = rank(x) - rank(y)$	d^2
12	6	6.5	3.5	3	9
8	5	2	2	0	0
16	7	9.5	5.5	4	16
12	7	6.5	5.5	1	1
7	4	1	1	0	0
10	6	4	3.5	0.5	0.25
12	8	6.5	7	0.5	0.25
16	13	9.5	10	0.5	0.25
12	10	6.5	8.5	2	4
9	10	3	8.5	5.5	30.25
					$\sum_{i=1}^{10} d_i^2 = 61$

Then

$$\rho = 1 - \frac{6 \times 61}{10(100-1)} \Leftrightarrow \rho = 1 - \frac{366}{990} \Leftrightarrow \rho = \frac{990-366}{990}$$

Or

$$\rho = 0.63$$

Application Activity 9.3

1. The scores of 12 students in their mathematics and physics classes are:

Mathematics	2	3	4	4	5	6	6	7	7	8	10	10
Physics	1	3	2	4	4	4	6	4	6	7	9	10

Find the coefficient of correlation distribution and interpret it.

2. The values of the two variables x and y are distributed according to the following table:

$y \backslash x$	0	2	4
1	2	1	3
2	1	4	2
3	2	5	0

Calculate the coefficient of correlation.

3. The marks of eight candidates in English and Mathematics are:

Candidate	1	2	3	4	5	6	7	8
English	50	58	35	86	76	43	40	60
Mathematics	65	72	54	82	32	74	40	53

Rank the results and hence find Spearman's rank coefficient of correlation between the two sets of marks. Comment on the value obtained.

4. Find Spearman's rank coefficient of correlation for the following data and interpret the value:

x	1	2.5	6	7	4.5	3	6.5
y	0.5	1	3.5	6.5	3	2.5	5.5

9.4. Applications

Activity 9.4



Discuss how statistics, especially bivariate statistics, can be used in our daily life.

Bivariate statistics can help in prediction of a value for one variable if we know the value of the other.

Example 9.9

One measure of personal fitness is the time taken for an individual's pulse rate to return to normal after strenuous exercise; the greater the fitness, the shorter the time. Following a short program of

strenuous exercise, Norman recorded his pulse rates P at time t minutes after he had stopped exercising. Norman's results are given in the table below:

t	0.5	1.0	1.5	2.0	3.0	4.0	5.0
P	125	113	102	94	81	83	71

Estimate Norman's pulse rate 2.5 minutes after stopping the exercise program.

Solution

t	P	t^2	P^2	tP
0.5	125	0.25	15625	62.5
1	113	1	12769	113
1.5	102	2.25	10404	153
2	94	4	8836	188
3	81	9	6561	243
4	83	16	6889	332
5	71	25	5041	355
$\sum_{i=1}^7 t_i = 17$	$\sum_{i=1}^7 P_i = 669$	$\sum_{i=1}^7 t_i^2 = 57.5$	$\sum_{i=1}^7 P_i^2 = 66125$	$\sum_{i=1}^7 t_i P_i = 1446.5$

We need the line $P = at + b$

Use the formula

$$\begin{cases} \sum_{i=1}^7 P_i = a \sum_{i=1}^7 t_i + 7b \\ \sum_{i=1}^7 t_i P_i = a \sum_{i=1}^7 t_i^2 + b \sum_{i=1}^7 t_i \end{cases}$$

We have

$$\begin{cases} 669 = 17a + 7b \\ 1446.5 = 57.5a + 17b \end{cases}$$

Solving, we have

$$\begin{cases} a = -11 \\ b = 122.3 \end{cases}$$

Then, $P = -11t + 122.3$

So,

Norman's pulse rate 2.5 minutes after stopping the exercise program is estimated to be $P = -11(2.5) + 122.3$ or 94.8.

Unit Summary

1. The **covariance of variables x and y** is a measure of how these two variables change together. It is defined to be

$$\text{cov}(x, y) = \frac{1}{n} \sum_{i=1}^k f_i (x_i - \bar{x})(y_i - \bar{y}) \quad \text{or} \quad \text{cov}(x, y) = \frac{1}{n} \sum_{i=1}^k f_i x_i y_i - \bar{x} \bar{y}$$

2. The regression line y on x is $L_{y/x} \equiv y - \bar{y} = \frac{\text{cov}(x, y)}{\sigma_x^2} (x - \bar{x})$
3. The regression line x on y is $L_{x/y} \equiv x - \bar{x} = \frac{\text{cov}(x, y)}{\sigma_y^2} (y - \bar{y})$

4. The coefficient of correlation between two variables x and y is given by

$$r = \frac{\text{cov}(x, y)}{\sigma_x \sigma_y}$$

5. The Spearman's coefficient of rank correlation is given by

$$\rho = 1 - \frac{6 \sum_{i=1}^k d_i^2}{n(n^2 - 1)}$$

Where, d refers to the difference of ranks between paired items in two series.

End of Unit Assessment

1. For each set of data, find;

- equation of the regression line of y on x
- equation of the regression line of x on y

Data set 1

x	3	7	9	11	14	14	15	21	22	23	26
y	5	12	5	12	10	17	23	16	10	10	25

Data set 2

x	1	5	5	5	6	7.5	7.5	7.5	10	11	12.5	14	14.5
y	85	82	85	89	78	66	77	81	70	74	65	69	63

2. The following is a summary of the results of given two variables:

$$\sum_{i=1}^k f_i x_i = 500, \sum_{i=1}^k f_i y_i = 300, \sum_{i=1}^k f_i x_i^2 = 27818, \sum_{i=1}^k f_i x_i y_i = 16837, \sum_{i=1}^k f_i y_i^2 = 10462$$

Find the equation of regression line of y on x .

Estimate the value of y for $x = 60$.

3. Compute the coefficient of correlation for the following series:

x	80	45	55	56	58	60	65	68	70	75	85
y	81	56	50	48	60	62	64	65	70	74	90

4. The following results were obtained from lineups in Mathematics and Physics examinations:

	Mathematics (x)	Physics (y)
Mean	475	39.5
Standard deviation	16.8	10.8

$$r = 0.95$$

Find both equations of the regression lines. Also estimate the value of y for $x = 30$.

5. The following results were obtained from records of age (x) and systolic blood pressure (y) of a group of 10 men:

	(x)	(y)
Mean	53	142
Variance	130	165

$$\sum_{i=1}^k f_i (x_i - \bar{x})(y_i - \bar{y}) = 1220$$

Find both equations of the regression lines. Also estimate the blood pressure of a man whose age is 45.

6. For a given set of data:

$$\sum_{i=1}^k f_i x_i = 15, \sum_{i=1}^k f_i y_i = 43, \sum_{i=1}^k f_i x_i^2 = 55, \sum_{i=1}^k f_i x_i y_i = 145, \sum_{i=1}^k f_i y_i^2 = 397, \sum_{i=1}^k f_i = 5$$

Find the equations of the regression lines y on x , and x on y .

7. For a set of 20 pairs of observations of the variables x and y , it is

known that $\sum_{i=1}^k f_i x_i = 250$, $\sum_{i=1}^k f_i y_i = 140$, and that the regression line of y on x passes through $(15, 10)$. Find the equation of that regression line and use it to estimate y when $x = 10$.

8. The gradient of the regression line x on y is -0.2 and the line passes through $(0, 3)$. If the equation of the line is $x = c + dy$, find the value of c and d and sketch the line on a diagram.

9. The heights h , in cm, and weights w , in kg, of 10 people are measured. It is found that

$$\sum_{i=1}^k f_i h_i = 1710, \sum_{i=1}^k f_i w_i = 760, \sum_{i=1}^k f_i h_i^2 = 293162, \sum_{i=1}^k f_i h_i w_i = 130628, \sum_{i=1}^k f_i w_i^2 = 59390$$

Calculate the coefficient of correlation between the value of h and w .

What is the equation of the regression line of w on h ?

10. The regression equations are $7x - 16y + 9 = 0$ and

$$5y - 4x - 3 = 0. \text{ Find } \bar{x}, \bar{y} \text{ and } r.$$

11. If two regression coefficients are 0.8 and 0.2 , what would be the value of coefficient of correlation?

12. For a given set of data:

$$\sum_{i=1}^k f_i x_i = 680, \sum_{i=1}^k f_i y_i = 996, \sum_{i=1}^k f_i x_i^2 = 20154, \sum_{i=1}^k f_i x_i y_i = 24844, \sum_{i=1}^k f_i y_i^2 = 34670, \sum_{i=1}^k f_i = 30$$

Find the coefficient of correlation.

13. For a set of data, the equations of the regression lines are
 $y = 0.648x + 2.64$ and $x = 0.917y - 1.91$

Find the coefficient of correlation.

14. For a set of data, the equations of the regression lines are
 $y = -0.219x + 20.8$ and $x = -0.785y + 16.2$

Find the coefficient of correlation.

15. For a set of data, the equations of the regression lines are
 $y = 1.3x + 0.4$ and $x = 0.7y - 0.1$

Find;

a) the coefficient of correlation. b) \bar{x} and \bar{y} .

16. In a partially destroyed laboratory record of an analysis of correlation data, the following results only are legible:
 Variance of x is 9

$$\text{Equations of regression lines: } 8x - 10y + 66 = 0 \text{ and } 40x - 18y - 214 = 0$$

What were:

- the mean values of x and y .
- the standard deviation of y , and
- the coefficient of correlation between x and y .

17. The following equations of regression lines and variance are obtained from a correlation table:

$$20x - 9y - 107 = 0, 4x - 5y + 33 = 0, \text{ variance of } x \text{ is } 9.$$

Find

- the mean value of x and y .
- the standard deviation of y .

18. The table below shows the marks awarded to six students in a competition:

Student	A	B	C	D	E	F
Judge 1	6.8	7.3	8.1	9.8	7.1	9.2
Judge 2	7.8	9.4	7.9	9.6	8.9	6.9

Calculate a coefficient of rank correlation.

19. At the end of a season, a league of eight hockey clubs produced the following table showing the position of each club in the league and the average attendances (in hundreds) at home matches.

Club	A	B	C	D	E	F	G	H
Position	1	2	3	4	5	6	7	8
Average position	27	29	9	16	24	15	12	22

- a) Calculate the Spearman's coefficient of rank correlation between position in the league and average attendance.
b) Comment on your results.

21. A company is to replace its fleet of cars. Eight possible models are considered and the transport manager is asked to rank them, from 1 to 8, in order of preference. A saleswoman is asked to use each type of car for a week and grade them according to their suitability for the job (*A*-very suitable to *E*-unsuitable).

The price is also recorded:

Model	Transport manager's ranking	Saleswoman's grade	Price (£10s)
S	5	B	611
T	1	B+	811
U	7	D-	591
V	2	C	792
W	8	B+	520
X	6	D	573
Y	4	C+	683
Z	3	A-	716

- a) Calculate the Spearman's coefficient of rank correlation between:
- price and transport manager's rankings,
 - price and saleswoman's grades.
- b) Based on the result of a, state, giving a reason, whether it would be necessary to use all the three different methods of assessing the cars.
- c) A new employee is asked to collect further data and to do some calculations. He produces the following results:
The coefficient of correlation between
- price and boot capacity is 1.2,
 - maximum speed and fuel consumption in miles per gallons is -0.7,
 - price and engine capacity is -0.9.
- For each of his results, say giving a reason, whether you think it is reasonable.
- d) Suggest two sets of circumstances where Spearman's coefficient of rank correlation would be preferred to the Pearson's coefficient of correlation as a measure of association.

22. The scores obtained by a group of students in tests that measure verbal ability (x) and abstract reasoning (y) are represented in the following table:

$y \backslash x$	20	30	40	50
(25-35)	6	4	0	0
(35-45)	3	6	1	0
(45-55)	0	2	5	3
(55-65)	0	1	2	7

- Is there a correlation between the two variables?
- According to the data, if one of these students obtained a score of 70 points in abstract reasoning, what would be the estimated score in verbal ability?

Unit 10

Conditional Probability and Bayes Theorem

Introductory activity

A box contains 3 red pens and 4 blue pens. One pen is taken from the box and is not replaced. Another pen is taken from the box. Let A be the event “the first pen is red” and B be the event “the second pen is blue.”

Is the occurrence of event B affected by the occurrence of event A ? Explain.

Give more other examples of real life problems involving probability.

Objectives

By the end of this unit, a student will be able to:

- ⊙ Use tree diagram to find probability of events.
- ⊙ Find probability of independent events.
- ⊙ Find probability of one event given that the other event has occurred.
- ⊙ Use and apply bayes theorem.

10.1. Tree diagram



Activity 10.1

A box contains 4 blue pens and 6 black pens. One pen is drawn at random, its color is noted and the pen is replaced in the box. A pen is again drawn from the box and its color is noted.

1. For the 1st trial, what is the probability of choosing a blue pen and probability of choosing a black pen?
2. For the 2nd trial, what is the probability of choosing a blue pen and probability of choosing a black pen? Remember that after the 1st trial, the pen is replaced in the box.
3. In the following figure, complete the missing colors and probabilities

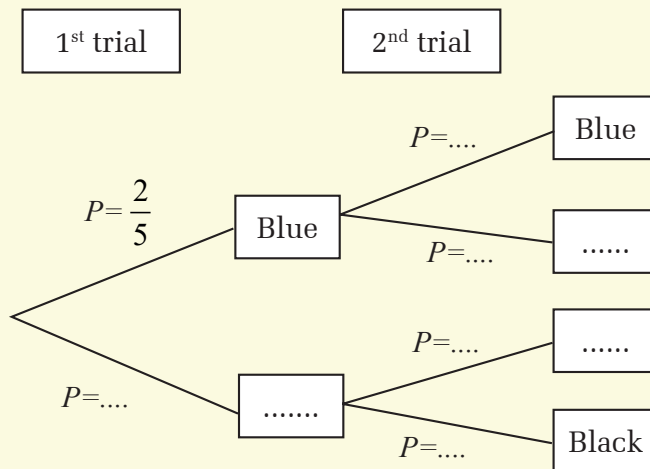

A **tree diagram** is a means which can be used to show the probabilities of certain **outcomes** occurring when two or more **trials** take place in succession.

The **outcome** is written at the end of the branch and the fraction on the branch gives the probability of the outcome occurring.

For each **trial**, the number of branches is equal to the number of possible outcomes of that trial. In the diagram there are two possible outcomes, A and B, of each trial.

Example 10.2

A bag (1) contains 4 red pens and 3 blue pens. Another bag (2) contains 3 red pens and 4 blue pens. A pen is taken from the first bag (1) and placed into the second bag (2). The second bag (2) is shaken and a pen is taken from it and placed in the first bag (1). If now a pen is taken from the first bag, use the tree diagram to find the probability that it is a red pen.

Solution

Tree diagram is given below:

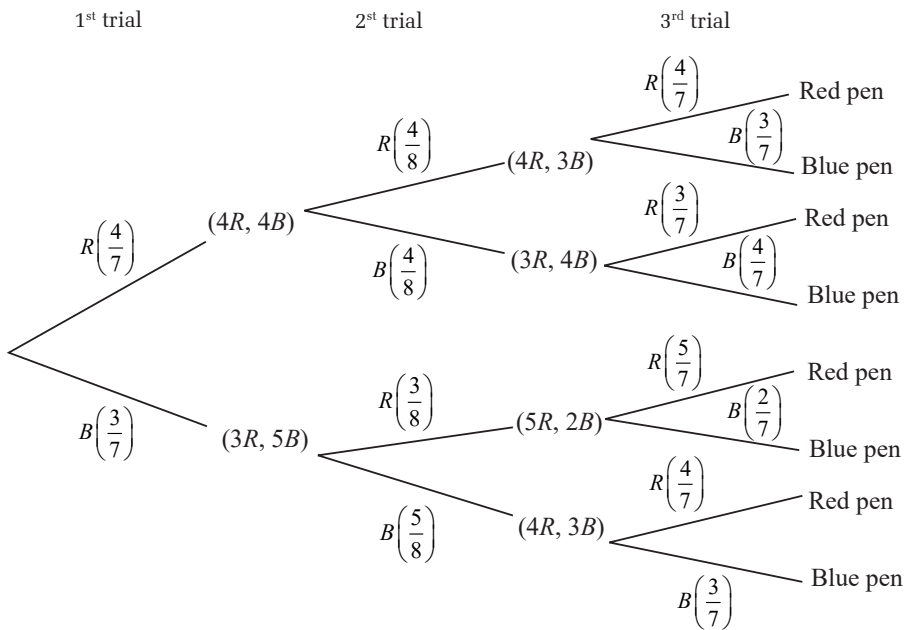

From tree diagram, the probability to have a red pen is

$$\begin{aligned}
 P(R) &= \frac{4}{7} \times \frac{4}{8} \times \frac{4}{7} + \frac{4}{7} \times \frac{4}{8} \times \frac{3}{7} + \frac{3}{7} \times \frac{3}{8} \times \frac{5}{7} + \frac{3}{7} \times \frac{5}{8} \times \frac{4}{7} \\
 &= \frac{64}{392} + \frac{48}{392} + \frac{45}{392} + \frac{60}{392} \\
 &= \frac{31}{56}
 \end{aligned}$$

Application Activity 10.1

- Calculate the probability of three coins landing on: Three heads.
- A class consists of six girls and 10 boys. If a committee of three is chosen at random, find the probability of:
 - Three boys being chosen.
 - Exactly two boys and a girl being chosen.
 - Exactly two girls and a boy being chosen.
 - Three girls being chosen.
- A bag contains 7 discs, 2 of which are red and 5 are green. Two discs are removed at random and their colours noted. The first disc is not replaced before the second is selected. Find the probability that the discs will be:
 - both red
 - of different colours
 - the same colours.
- Three discs are chosen at random, and without replacement, from a bag containing 3 red, 8 blue and 7 white discs. Find the probability that the discs chosen will be:
 - all red
 - all blue
 - one of each colour.

10.2. Independent events



Activity 10.2

A box contains 3 red pens, 4 green pens and 5 blue pens. One pen is taken from the box and then replaced. Another pen is taken from the box. Let A be the event “the first pen is red” and B be the event the second pen is blue.”

Is the occurrence of event B affected by the occurrence of event A ? Explain.

If probability of event B is not affected by the occurrence of event A , events A and B are said to be **independent** and

$$P(A \cap B) = P(A) \times P(B)$$

This rule is the simplest form of the **multiplication law** of probability.

Example 10.3

A die is thrown twice. Find the probability of obtaining a 4 on the first throw and an odd number on the second throw.

Solution

Let A be the event: "a 4 is obtained on the first throw", then

$$P(A) = \frac{1}{6}. \text{ That is } A = \{4\}$$

Let B be the event: "an odd number is obtained on the second throw". That is $B = \{1, 3, 5\}$

Since the result on the second throw is not affected by the result on the first throw, A and B are independent events.

There are 3 odd numbers, then

$$P(B) = \frac{3}{6} = \frac{1}{2}$$

Therefore,

$$\begin{aligned} P(A \cap B) &= P(A)P(B) \\ &= \frac{1}{6} \times \frac{1}{2} \\ &= \frac{1}{12} \end{aligned}$$

Example 10.4

A factory runs two machines. The first machine operates for 80% of the time while the second machine operates for 60% of the time and at least one machine operates for 92% of the time. Do these two machines operate independently?

Solution

Let the first machine be M_1 and the second machine be M_2 , then $P(M_1) = 80\% = 0.8$, $P(M_2) = 60\% = 0.6$ and $P(M_1 \cup M_2) = 92\% = 0.92$

Now,

$$P(M_1 \cup M_2) = P(M_1) + P(M_2) - P(M_1 \cap M_2)$$

$$P(M_1 \cap M_2) = P(M_1) + P(M_2) - P(M_1 \cup M_2)$$

$$= 0.8 + 0.6 - 0.92$$

$$= 0.48$$

$$= 0.8 \times 0.6$$

$$= P(M_1) \times P(M_2)$$

Thus, the two machines operate independently.

Example 10.5

A coin is weighted so that heads is three times as likely to appear as tails. Find $P(H)$ and $P(T)$.

Solution

Let $P(T) = p_1$, then $P(H) = 3p_1$.

But $P(H) + P(T) = 1$

Therefore, $p_1 + 3p_1 = 1 \Leftrightarrow 4p_1 = 1 \Rightarrow p_1 = \frac{1}{4}$

Thus, $P(H) = \frac{3}{4}$ and $P(T) = \frac{1}{4}$.

Application Activity 10.2

1. A dresser drawer contains one pair of socks with each of the following colors: blue, brown, red, white and black. Each pair is folded together in a matching set. You reach into the sock drawer and choose a pair of socks without looking. You replace this pair and then choose another pair of socks. What is the probability that you will choose the red pair of socks both times?
2. A coin is tossed and a single 6-sided die is rolled. Find the probability of landing on the head side of the coin and rolling a 3 on the die.

3. A husband and a wife appear in an interview for two vacancies in the same post. The probability of husband's selection is $\frac{1}{7}$ and that of wife's selection is $\frac{1}{5}$. What is the probability that:
- both of them will be selected?
 - only one of them will be selected, and none of them will be selected?

10.3. Conditional probability

Activity 10.3



A box contains 3 red pens, 4 green pens and 5 blue pens. One pen is taken from the box and is not replaced. Another pen is taken from the box. Let A be the event “the first pen is red” and B be the event “the second pen is blue”.

Is the occurrence of event B affected by the occurrence of event A ? Explain.

The probability of an event B given that event A has occurred is called the **conditional probability** of B given A and is written $P(B|A)$.

In this case, $P(B|A)$ is the probability that B occurs considering A as the sample space, and since the subset of A in which B occurs is $A \cap B$, then

$$P(B|A) = \frac{P(B \cap A)}{P(A)}.$$

From this result, we have general statement of the multiplication law:

$$P(A \cap B) = P(A) \times P(B|A).$$

This shows us that the probability that two events will both occur is the product of the probability that one will occur and the conditional probability that the other will occur given that the first has occurred. We can also write $P(A \cap B) = P(B) \times P(A|B)$ since A and B are interchangeable.

If A and B are **independent**, then the probability of B is not affected by the occurrence of A and so $P(B|A) = P(B)$ giving $P(A \cap B) = P(A) \times P(B)$

Example 10.6

A die is tossed. Find the probability that the number obtained is a 4 given that the number is greater than 2.

Solution

Let A be the event: “the number is a 4”, then $A = \{4\}$

Let B be the event: “the number is greater than 2”, then $B = \{3, 4, 5, 6\}$

and $P(B) = \frac{4}{6} = \frac{2}{3}$

But $A \cap B = \{4\}$ and $P(A \cap B) = \frac{1}{6}$

Therefore,

$$P(A|B) = \frac{P(A \cap B)}{P(B)}$$

$$P(A|B) = \frac{\frac{1}{6}}{\frac{2}{3}} \quad P(A|B) = \frac{1}{6} \times \frac{3}{2}$$

$$= \frac{1}{4}$$

Example 10.7

At a middle school, 18% of all students play football and basketball, and 32% of all students play football. What is the probability that a student who plays football also plays basketball?

Solution

Let A be a set of students who play football and B a set of students who play basketball; then the set of students who play both games is $A \cap B$. We have $P(A) = 32\% = 0.32$, $P(A \cap B) = 18\% = 0.18$. We need the probability of B known that A has occurred.

Therefore,

$$P(B|A) = \frac{P(A \cap B)}{P(A)}$$

$$= \frac{0.18}{0.32} = 0.5625 = 56\%$$



Notice

Contingency table

Contingency table (or **two-way table**) provides a different way of calculating probabilities. The table helps in determining conditional probabilities quite easily. The table displays sample values in relation to two different variables that may be dependent or contingent on one another.

Below, the contingency table shows the favorite leisure activities for 50 adults, 20 men and 30 women. Because entries in the table are frequency counts, the table is a **frequency table**.

	Dance	Sports	TV	Total
Men	2	10	8	20
Women	16	6	8	30
Total	18	16	16	50

Entries in the total row and total column are called **marginal frequencies** or the **marginal distribution**. Entries in the body of the table are called **joint frequencies**.

Example 10.8

Suppose a study of speeding violations and drivers who use car phones produced the following fictional data:

	Speeding violation in the last year	No speeding violation in the last year	Total
Car phone user	25	280	305
Not a car phone user	45	405	450
Total	70	685	755

Calculate the following probabilities using the table:

- $P(\text{person is a car phone user})$.
- $P(\text{person had no violation in the last year})$.
- $P(\text{person had no violation in the last year AND was a car phone user})$.
- $P(\text{person is a car phone user OR person had no violation in the last year})$.

- e) P(person is a car phone user GIVEN person had a violation in the last year).
- f) P(person had no violation last year GIVEN person was not a car phone user).

Solution

- a) $P(\text{person is a car phone user}) = \frac{\text{number of car phone users}}{\text{total number in study}} = \frac{305}{755}$
- b) $P(\text{person had no violation in the last year}) = \frac{\text{number that had no violation}}{\text{total number in study}} = \frac{685}{755}$
- c) $P(\text{person had no violation in the last year AND was a car phone user}) = \frac{280}{755}$
- d) $P(\text{person is a car phone user OR person had no violation in the last year})$
 $= \left(\frac{305}{755} + \frac{685}{755} \right) - \frac{280}{755} = \frac{710}{755}$
- e) The sample space is reduced to the number of persons who had a violation. Then
 $P(\text{person is a car phone user GIVEN person had a violation in the last year}) = \frac{25}{70}$
- f) The sample space is reduced to the number of persons who were not car phone users. Then
 $P(\text{person had no violation last year GIVEN person was not a car phone user}) = \frac{405}{450}$

Application Activity 10.3

1. Calculate the probability of a 6 being rolled by a die if it is already known that the result is even.
2. A jar contains black and white marbles. Two marbles are chosen without replacement. The probability of selecting a black marble and then a white marble is 0.34, and the probability of selecting a black marble on the first draw is 0.47. What is the probability of selecting a white marble on the second draw, given that the first marble drawn was black?

3. A bag contains five discs, three of which are red. A box contains six discs, four of which are red. A card is selected at random from a normal pack of 52 cards, if the card is a club, a disc is removed from the bag and if the card is not a club, a disc is removed from the box. Find the probability that, if the removed disc is red it came from the bag.

10.4. Bayes theorem and its applications



Activity 10.4

Suppose that entire output of a factory is produced on three machines. Let B_1 denote the event that a randomly chosen item was made by machine 1, B_2 denote the event that a randomly chosen item was made by machine 2 and B_3 denote the event that a randomly chosen item was made by machine 3. Let A denote the event that a randomly chosen item is defective.

1. Use conditional probability formula and give the relation that should be used to find the probability that the chosen item is defective, $P(A)$, given that it is made by machine 1 or machine 2 or machine 3.
2. If we need the probability that the chosen item is produced by machine 1 given that it is found to be defective, i.e $P(B_1 | A)$, give the formula for this conditional probability. Recall that $P(B_i \cap A)$ can be written as $P(A | B_i)P(B_i)$. Do the same if the item is produced by machine 2 and by machine 3. Give the general formula if the item is produced by machine i (i from 1 to 3)

From Activity 10.4

Let $B_1, B_2, B_3, \dots, B_n$ be incompatible and exhaustive events and let A be an arbitrary event.

We have:

$$P(B_i | A) = \frac{P(B_i \cap A)}{P(A)} = \frac{P(A | B_i)P(B_i)}{\sum_{i=1}^n P(A | B_i)P(B_i)}$$

This formula is called Bayes' formula.

Remark

We also have (Bayes' rule) $P(B | A) = \frac{P(A | B)P(B)}{P(A)}$

Example 10.9

Suppose that machines M_1 , M_2 , and M_3 produce respectively 500, 1000, and 1500 parts per day, of which 5%, 6%, and 7% are defective. A part produced by one of these machines is taken at random, at the end of a given workday, and it is found to be defective. What is the probability that it was produced by machine M_3 ?

Solution

Let A_i be the event "the part taken at random was produced by machine M_i ", for $i = 1, 2, 3$; and let D be "the part taken at random is defective".

Using Bayes' formula, we seek

$$\begin{aligned} P(A_3 | D) &= \frac{P(D | A_3)P(A_3)}{\sum_{i=1}^3 P(D | A_i)P(A_i)} \\ &= \frac{(0.07)\left(\frac{1500}{3000}\right)}{(0.05)\left(\frac{1}{6}\right) + (0.06)\left(\frac{1}{3}\right) + (0.07)\left(\frac{1}{2}\right)} \\ &= \frac{105}{190} \\ &= \frac{21}{38} \end{aligned}$$

Example 10.10

Two machines A and B produce 60% and 40% respectively of total output of a factory. Of the parts produced by machine A, 3% are defective and of the parts produced by machine B, 5% are defective. A part is selected at random from a day's production and found to be defective. What is the probability that it came from machine A?

Solution

Let E be the event that the part came from machine A,
C be the event that the part came from machine B and
D be the event that the part is defective.

$$\text{We require } P(E/D) = \frac{P(D/E)P(E)}{P(D)}$$

$$\text{Now, } P(E) \times P(D|E) = 0.6 \times 0.03 = 0.018 \text{ and}$$

$$\begin{aligned} P(D) &= P(E \cap D) + P(C \cap D) \\ &= 0.018 + 0.4 \times 0.05 \\ &= 0.038 \end{aligned}$$

Therefore, the required probability is $\frac{0.018}{0.038} = \frac{9}{19}$

Application 10.4

- 20% of a company's employees are engineers and 20% are economists. 75% of the engineers and 50% of the economists hold a managerial position, while only 20% of non-engineers and non-economists have a similar position. What is the probability that an employee selected at random will be an engineer knowing that he is a manager?
- The probability of having an accident in a factory that triggers an alarm is 0.1. The probability of its sounding after the event of an incident is 0.97 and the probability of it sounding after no incident has occurred is 0.02. In an event where the alarm has been triggered, what is the probability that there has been no accident?

Unit Summary

1. A tree diagram is a means which can be used to show the probabilities of certain outcomes occurring when two or more trials take place in succession. The outcome is written at the end of the branch and the fraction on the branch gives the probability of the outcome occurring. For each trial, the number of branches is equal to the number of possible outcomes of that trial. In the diagram, there are two possible outcomes, A and B , of each trial.
2. Events A and B are said to be **independent** if and only if $P(A \cap B) = P(A) \times P(B)$
3. The probability of an event B given that event A has occurred is called the **conditional probability** of B given A and is written $P(B|A)$. In this case, $P(B|A)$ is the probability that B occurs considering A as the sample space, and since the subset of A in which B occurs is $A \cap B$, then $P(B|A) = \frac{P(B \cap A)}{P(A)}$.
4. Let $B_1, B_2, B_3, \dots, B_n$ be incompatible and exhaustive events and A an arbitrary event. The **Bayes' formula** says that

$$P(B_i|A) = \frac{P(B_i \cap A)}{P(A)} = \frac{P(A|B_i)P(B_i)}{\sum_{i=1}^n P(A|B_i)P(B_i)}$$

End of Unit Assessment

1. The probability that it is Friday and that a student is absent is 0.03. Since there are 5 school days in a week, the probability that it is Friday is 0.2. What is the probability that a student is absent given that today is Friday?
2. At Kennedy Middle School, the probability that a student takes Technology and Spanish is 0.087. The probability that a student takes Technology is 0.68. What is the probability that a student takes Spanish given that the student is taking Technology?
3. A car dealership is giving away a trip to Rome to one of their 120 best customers. In this group, 65 are women, 80 are married and 45 married women. If the winner is married, what is the probability that it is a woman?
4. A card is chosen at random from a deck of 52 cards. It is then replaced and a second card is chosen. What is the probability of choosing a jack and then an eight?
5. A jar contains 3 red, 5 green, 2 blue and 6 yellow marbles. A marble is chosen at random from the jar. After replacing it, a second marble is chosen. What is the probability of choosing a green and then a yellow marble?
6. A school survey found that 9 out of 10 students like pizza. If three students are chosen at random with replacement, what is the probability that all the three students like pizza?
7. A nationwide survey found that 72% of people in the United States like pizza. If 3 people are selected at random, one after another, with replacement, what is the probability that all the three like pizza?
8. A bag contains 2 red, 3 green and 2 blue balls. Two balls are drawn at random. What is the probability that none of the balls drawn is blue?

9. For married couples living in a certain suburb, the probability that the husband will vote on a bond referendum is 0.21, the probability that his wife will vote in the referendum is 0.28, and the probability that both the husband and wife will vote is 0.15. What is the probability that:
- at least one member of a married couple will vote?
 - a wife will vote, given that her husband will vote?
 - a husband will vote, given that his wife does not vote?
10. In 1970, 11% of Americans completed four years of college, 43% of them were women. In 1990, 22% of Americans completed four years of college; 53% of them were women. (Time, Jan.19, 1996).
- Given that a person completed four years of college in 1970, what is the probability that the person was a woman?
 - What is the probability that a woman would finish four years of college in 1990?
11. If the probability is 0.1 that a person will make a mistake on his or her state income tax return, find the probability that:
- four totally unrelated persons each make a mistake
 - Mr. Jones and Ms. Clark both make a mistake and Mr. Roberts and Ms. Williams do not make a mistake.
12. The probability that a patient recovers from a delicate heart operation is 0.8. What is the probability that:
- exactly 2 of the next 3 patients who have this operation will survive?
 - all of the next 3 patients who have this operation survive?
13. In a certain federal prison, it is known that $\frac{2}{3}$ of the inmates are under 25 years of age. It is also known that $\frac{3}{5}$ of the inmates are male and that $\frac{5}{8}$ of the inmates are female or 25 years of age or older. What is the probability that a prisoner selected at random from this prison is female and at least 25 years old?

14. A certain federal agency employs three consulting firms (A, B and C) with probabilities 0.4, 0.35, 0.25, respectively. From past experience, it is known that the probabilities of cost overrun for the firms are 0.05, 0.03, and 0.15 respectively. Suppose a cost overrun is experienced by the agency.
- What is the probability that the consulting firm involved is company C?
 - What is the probability that it is company A?
15. In a certain college, 5% of the men and 1% of the women are taller than 180 *cm*. Also, 60% of the students are women. If a student is selected at random and found to be taller than 180 *cm*, what is the probability that this student is a woman?

References

- [1] A. J. Sadler, D. W. S. Thorning: *Understanding Pure Mathematics*, Oxford University Press 1987.
- [2] Arthur Adam Freddy Goossens: Francis Lousberg. *Mathématisons 65*. DeBoeck, 3e edition 1991.
- [3] David Rayner, *Higher GCSE Mathematics*, Oxford University Press 2000
- [4] Direction des Programmes de l'Enseignement Secondaire. *Géométrie de l'Espace 1er Fascule*. Kigali, October 1988
- [5] Direction des Programmes de l'Enseignement Secondaire. *Géométrie de l'Espace 2ème Fascule*. Kigali, October 1988
- [6] Frank Ebos, Dennis Hamaguchi, Barbana Morrison & John Klassen, *Mathematics Principles & Process*, Nelson Canada A Division of International Thomson Limited 1990
- [7] George B. Thomas, Maurice D. Weir & Joel R. Hass, *Thomas' Calculus Twelfth Edition*, Pearson Education, Inc. 2010
- [8] Geoff Mannall & Michael Kenwood, *Pure Mathematics 2*, Heinemann Educational Publishers 1995
- [9] H.K. DASS... *Engineering Mathematics*. New Delhi, S. Chand & Company LTD, thirteenth revised edition 2007.
- [10] Hubert Carnec, Genevieve Haye, Monique Nouet, Rene Seroux, Jacqueline Venard. *Mathématiques TS Enseignement obligatoire*. Bordas Paris 1994.
- [11] James T. McClave, PGeorge Benson. *Statistics for Business and Economics*. USA, Dellen Publishing Company, a division of Macmillan, Inc 1988.
- [12] J Crawshaw, J Chambers: *A concise course in A-Level statistics with worked examples*, Stanley Thornes (Publishers) LTD, 1984.
- [13] Jean Paul Beltramonde, Vincent Brun, Claude Felloneau, Lydia Misset, Claude Talamoni. *Decllic 1re S Mathématiques*. Hachette-education, Paris 2005.
- [14] JF Talber & HH Heing, *Additional Mathematics 6th Edition Pure & Applied*, Pearson Education South Asia Pte Ltd 1995
- [15] J.K. Backhouse, SPTHouldsworth B.E.D. Copper and P.J.F. Horril. *Pure Mathematics 2*. Longman, third edition 1985, fifteenth impression 1998.
- [16] M.Nelkon, P. Parker. *Advanced Level Pysics, Seventh Edition*. Heinemann 1995

- [17] Mukasonga Solange. *Mathématiques 12, Analyse Numérique*. KIE, Kigali 2006.
- [18] N. Piskounov, *Calcul Différentiel et Integral tom II 9ème édition*. Editions MIR. Moscou, 1980.
- [19] Paule Faure- Benjamin Bouchon, *Mathématiques Terminales F* Editions Nathan, Paris 1992.
- [20] Peter Smythe: *Mathematics HL & SL with HL options, Revised Edition*, Mathematics Publishing Pty. Limited, 2005.
- [21] Rwanda Basic Education Board (2015), *Mathematics Syllabus for Advanced Level S4-S6*, Ministry of Education: Rwanda.
- [22] Robert A. Adms & Christopher Essex, *Calculus A complete course* Seventh Edition, Pearson Canada Inc., Toronto, Ontario 2010
- [23] Seymour Lipschutz. *Schaum's outline of Theory and Problems of linear algebra*. McGraw-Hill 1968.
- [24] Shampiyona Aimable : *Mathématiques 6*. Kigali, Juin 2005.
- [25] Tom Duncan, *Advanced Physics, Fourth edition*. John Murray (Publishers) Ltd, London 1998
- [26] Yves Noirot, Jean-Paul Parisot, Nathalie Brouillet. *Cours de Physique Mathématiques pour la Physique*. Paris, DUNOD, 1997.